

Outphasing Control of Gallium Nitride based Very High Frequency Resonant Converters

Mickey P. Madsen, Arnold Knott, Michael A.E. Andersen
*Technical University of Denmark,
Department of Electrical Engineering,
Oersteds Plads 349, DK-2800 Kgs Lyngby, Denmark*

David J. Perreault
*Massachusetts Institute of Technology,
The Laboratory for Electromagnetic and Electronic Systems,
77 Massachusetts Avenue, MA-02139 Cambridge, USA*

Abstract — In this paper an outphasing modulation control method suitable for line regulation of very high frequency resonant converters is described.

The pros and cons of several control methods suitable for very high frequency resonant converters are described and compared to outphasing modulation. Then the modulation technique is described and the design equations given.

Finally a design example is given for a converter consisting of two class E inverters with a lossless combiner and a common half bridge rectifier. It is shown how outphasing modulation can be used for line regulation while insuring equal and purely resistive loading of the inverters. Combined with a proper design of the inverters that, insures they can achieve zero voltage switching across a wide load range, and gallium nitride FETs for the switching devices, this makes it possible to achieve more than 90% efficiency across most of the input voltage range with good line regulation.

Keywords — Gallium nitride, Phase control, Power control, VHF circuits, Zero voltage switching.

I. INTRODUCTION

The development of Switch-Mode Power Supplies (SMPS) has made it possible to increase the power density of power converters significantly. Modern power supplies are however limited by the passive energy storing elements, which is needed to store energy between each switching period. The size of these components scale inversely with the switching frequency, and there have therefore been a constant strive for higher switching frequencies ever since. Commercially available converters today switch at frequencies up to several megahertz and can have efficiencies of more than 95% (e.g. [1]).

The reason not to increase the switching frequency further, and thereby reaching even higher power densities, is the switching losses. For more than two decades (since 1988 [2]) research has been done, in order to enable the use of resonant RF amplifiers (inverters) combined with a rectifier for dc/dc converters, in order to avoid switching losses. With this type of converters, SMPSs with switching frequencies in the Very High Frequency range (VHF, 30-300MHz) have been designed with efficiencies up to approx. 90% [3], [4].

Several of the benefits and challenges of the increased switching frequency are described in [5], [6]. Among the benefits are higher power densities, lower weight and removed need for electrolytic capacitors and magnetic core materials

[7]. The increased frequency also enables the possibility of very fast transient responses, to achieve this a fast and efficient control scheme is needed. This together with the fact that resonant converters are very load dependent remains two of the major challenges for very high frequency resonant converters.

In section II of this paper different control schemes for resonant converters are investigated and compared. Section III describes a method for efficient outphasing control of resonant converters. Section IV covers the design and simulation of a converter with the described control and finally section V concludes the paper.

II. CONTROL OF RESONANT CONVERTERS

Resonant converters are dependent on precise timing between the resonances in the power stage and the switching of the power semiconductors. The resonances in the power stage are used to shape the voltages and currents, so that the voltage across or the current through the power semiconductors are zero at the switching instant, known as zero-voltage-switching (ZVS) and zero-current-switching (ZCS).

In power applications the energy stored in the parasitic capacitance of the switching device is generally the dominating contributor to switching losses, hence ZVS is crucial to insure high efficiency when the switching frequency is pushed into the VHF range.

Pulse width modulation (PWM) is the most commonly used control scheme for power converters, but if a resonant converter is controlled in this way, ZVS is lost as soon as the duty cycle moves away from one optimal value.

Pulse frequency modulation (PFM) is another option, but it requires a very wide frequency operation range to insure even a limited controllability of the converter. Combinations of PWM and PFM have shown good results [8], but the control circuit becomes quite complex and still requires a wide frequency operation range.

A. Burst mode control

So far the most commonly used control method for VHF converters has been burst mode control (also called cell modulation, on-off or bang-bang control) [4], [9]-[12]. Here the entire converter is switched on and off in order to control the output. The benefit of controlling the converter in this way is that the converter will either be on and working in its optimal operating point or off with only small standby losses. The result is a wide control range with an almost flat efficiency curve [4], [10]. Further the converter can be optimized for high

peak efficiency in this specific operation point instead of compromising the peak efficiency for higher average efficiency.

One down side of burst mode control is that low frequency harmonics is introduced, which increase the size of the needed input and output filters. Another is added circuitry that adds both to complexity and to the losses, which reduces the efficiency at full load. Further burst mode requires the converter to be able to start and reach steady state quickly, most implementations use a burst frequency approximately two decades below the switching frequency in order to insure that the converter has time to reach steady state and operate efficiently for some time before it is shut down again [4], [9]-[12].

Several control schemes for burst mode control are available with hysteresis [4], [9]-[10] and PWM [11] being the most commonly used, phase shift [12] and constant on time are two other alternatives.

Hysteresis control has the best transient response, as the transitions between the on and off states are defined by the hysteresis window, instead of a fixed frequency or times as in the other schemes. Another advantages is very good efficiency at light loads due to a very low burst frequency. These advantages come at the expense of widely varying burst frequencies increases the complexity and potentially size of the needed input/EMI filter.

The design of the input filter is more straightforward with PWM where a fixed burst frequency is used, but the transient response and light load efficiency degrades. The performance of a VHF converter controlled by PWM burst mode, is in many aspects similar to a conventional hard switched converter operating at the burst frequency.

Phase shift control has the same pros and cons as hysteresis control, but the delay in the control circuitry is utilized in the design which makes it possible to use slower components than would have been needed with hysteresis control.

Constant on time control can be compared to PWM control, but with the on time fixed instead of the frequency. This gives a more stable frequency than seen for hysteresis and phase shift control, but still with good light load efficiency.

B. Outphasing

Outphasing, also referred to as Linear Amplification with Nonlinear Components (LINC), was introduced for RF amplifiers in the 1930's [13]. This control method has however only been used a few times in previous publication [14]-[15] and posses several advantages compared to burst mode.

Outphasing control utilizes a phase shift between two or more inverters to control the combined output through a common rectifier, as illustrated with two inverters in Fig. 1. In this way the individual inverters run continuously at a fixed frequency while the total output to the load is regulated.

With this control method all the benefits of the high switching frequency can be achieved, both fast transient response, wide control range and small input and output filters.

The main drawback of outphasing is that the losses in the inverters are almost constant at light and full load, which decrease the light load efficiency significantly. Further the varying load and the inverters impact on each other is a challenge, this will be investigated further in section III.

III. PROPOSED OUTPHASING SYSTEM

Selecting the right combiner is crucial to achieve a good result with outphasing. Several approaches have been suggested [16]-[19], but the lossless combiner proposed in [20] (shown in Fig. 2) posses several benefits for use in resonant converters. The combiner only consists of an inductor and capacitor, if these are assumed ideal the combiner is lossless. Further the admittance seen by the two inverters can be made zero, insuring purely resistive loading of the inverters. As resonant converters are very load dependent and quickly loses ZVS when load reactively this is crucial in order to insure high efficiency.

The input impedance of the rectifier, R_{REC} , can be assumed purely resistive at the switching frequency. Further the output voltage of the two inverters, V_{INV1} and V_{INV2} , can be assumed equal to:

$$V_{INV1} = V_{IN} \cdot G_{INV} \cdot e^{-j\varphi} \quad (1)$$

$$V_{INV2} = V_{IN} \cdot G_{INV} \cdot e^{+j\varphi} \quad (2)$$

Where V_{IN} is the input voltage, G_{INV} is a fixed gain between the input voltage to the converters and the peak output voltage.

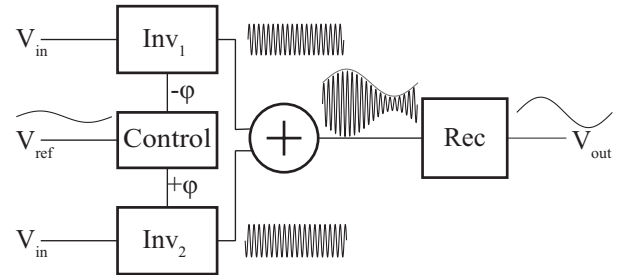

Fig. 1. System view of a converter using outphasing modulation.

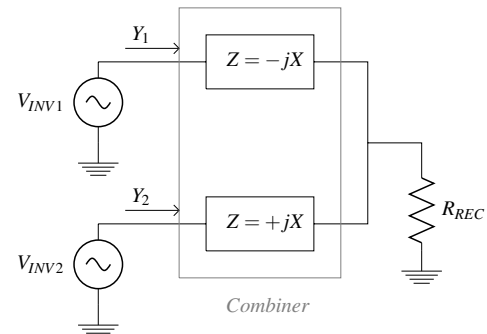

Fig. 2. Schematic of the lossless combiner for outphasing modulation.

The admittance seen by the two inverters is now written as:

$$Y_1 = \frac{1}{X} - \frac{I \cdot e^{j\varphi} \cdot V_{OUT}}{X \cdot V_{IN} \cdot G_{INV} \cdot G_{REC}} \quad (3)$$

$$Y_2 = \frac{1}{X} - \frac{I \cdot V_{OUT}}{X \cdot e^{j\varphi} \cdot V_{IN} \cdot G_{INV} \cdot G_{REC}} \quad (4)$$

Where G_{REC} is a fixed voltage gain from the peak input voltage of the rectifier to the output voltage, V_{OUT} . The imaginary part of the admittance is:

$$\Im(Y_1) = \frac{1}{X} - \frac{V_{OUT} \cdot \cos(\varphi)}{X \cdot V_{IN} \cdot G_{INV} \cdot G_{REC}} \quad (5)$$

$$\Im(Y_2) = -\frac{1}{X} + \frac{V_{OUT} \cdot \cos(\varphi)}{X \cdot V_{IN} \cdot G_{INV} \cdot G_{REC}} \quad (6)$$

Setting this to zero and solving for the phase, φ , gives:

$$\varphi = \arccos\left(\frac{V_{IN} \cdot G_{INV} \cdot G_{REC}}{V_{OUT}}\right) \quad (7)$$

If the phase is controlled according to this equation, the loading of the inverters will be purely resistive. The real part of the admittance is:

$$\Re(Y_1) = \Re(Y_2) = \frac{V_{OUT} \cdot \sin(\varphi)}{X \cdot V_{IN} \cdot G_{INV} \cdot G_{REC}} \quad (8)$$

From this the output power, P_{OUT} , can be calculated for a given value of the combiner reactance, X , and input and output voltage by:

$$P_{OUT} = \frac{G_{INV} \cdot V_{IN} \sqrt{V_{OUT}^2 - V_{IN}^2 \cdot G_{INV}^2 \cdot G_{REC}^2}}{X \cdot G_{REC}} \quad (9)$$

From (8) it is seen that it is not possible to control the power, if the loading of the converters needs to be purely resistive. If the output voltage is kept fixed, the output power will however be a quadratic function of the input voltage that can be offset by the chosen reactance for the combiner.

IV. DESIGN AND SIMULATION

The outphasing modulation will be evaluated for use as line control of a resonant converter with the specifications given in table 1. The aim is to use outphasing to achieve max +/- 20% output power variation for a input variation of +/- 33%.

TABLE I. SPECIFICATIONS FOR THE CONVERTER.

Input voltage	Output voltage	Frequency	Output power
12-24 V	54 V	30 MHz	10-15 W

Equation (7) shows that it is only possible to adjust the phase to give a purely resistive loading of the inverters, if the input voltage multiplied by the combined gain of the inverter and rectifier is less than or equal to the output voltage. This is because outphasing modulation can only be used to reduce the output power, from the power that would be delivered if the two inverters where operating in phase.

Due to the high switching frequency class E inverters with only low side switches are chosen. Other suitable topologies, such as the class Φ_2 [4] or class DE [21], could have been

chosen, but the class E inverter is chosen due to the low input voltage and its simplicity.

A half bridge rectifier with a gain of exactly $4/\pi$ is selected due to the high output voltage. The gain of a class E inverter is $\pi/2$. With these gains the phase, output power, load resistance and reactance can be calculated, results shown in Fig 3-6.

The value of the combiner reactances is set to 56Ω , corresponding to a 300 nH inductor and 94 pF capacitor, in order to achieve a output power which is 14 W in average. The 14 W is based on the assumption that the total system efficiency will be around 90% and that 1.4 W hence will be lost in the converter. Fig. 5-6 clearly shows the purely resistive loading of the converter with a value between 28 and 110Ω across the input voltage range. The complete circuit is shown in Fig. 7.

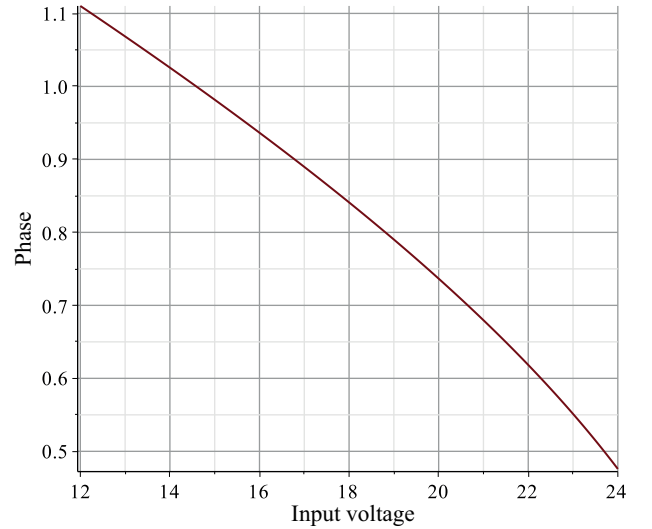

Fig. 3. The phase shift needed across the input voltage range for purely resistive loading of the inverters (in radians).

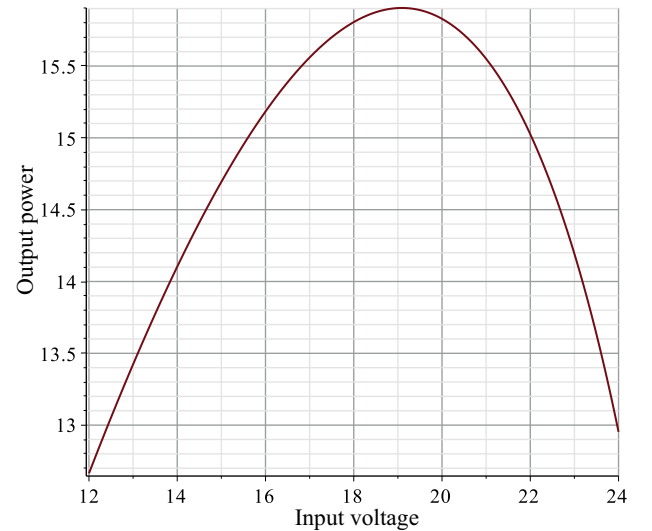

Fig. 4. The achieved output power across the input voltage range. The reactance of the combiner is set to 56Ω to achieve the desired output power plus 10% that is expected to be losses.

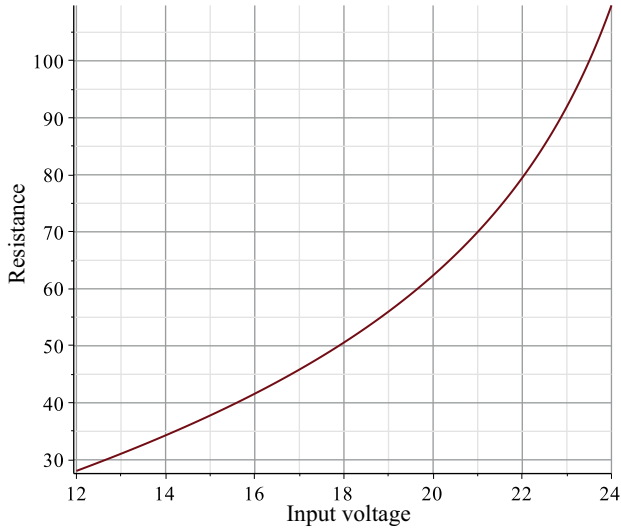

Fig. 5. The load resistance seen by the inverters across the input voltage range.

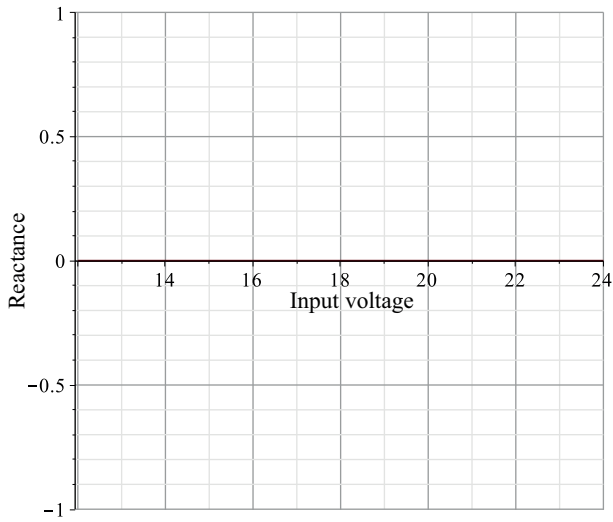

Fig. 6. The load reactance seen by the inverters across the input voltage range, it is zero across the range as it should be.

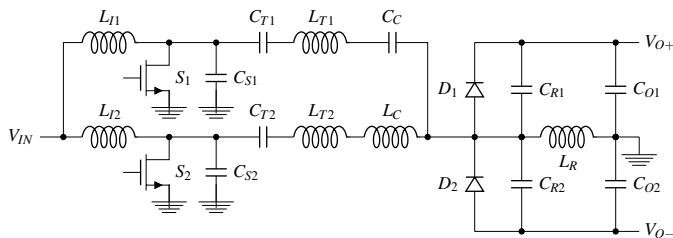

Fig. 7. Schematic of the two inverters, the combiner and the half bridge rectifier.

The two inverters are designed to be identical and based on the methodology described in [22], but without the parallel resonant tank. The values of the input inductors, L_{I1} and L_{I2} , and the switch capacitances, C_{S1} and C_{S2} , are given by the equations:

$$L_{I1} = L_{I2} = \frac{Q_S \cdot R_{\min}}{k \cdot 2 \cdot \pi \cdot f_s} \quad (10)$$

$$C_{S1} = C_{S2} = \frac{1}{Q_S \cdot R_{\min} \cdot k \cdot 2 \cdot \pi \cdot f_s} \quad (11)$$

Where $R_{\min} = 28 \Omega$, $f_s = 30 \text{ MHz}$ and Q_S and k are set to 0.7 and $\sqrt{2}$, respectively. This gives inductor values of 832 nH and capacitances of 192 pF. EPCs 8010 GaN FETs are selected for the switches and their parasitic output capacitance combined with additional 140 pF composes C_{S1} and C_{S2} . The values of the resonant tanks components, C_{T1} , C_{T2} , L_{T1} and L_{T2} , are also calculated based on (10) and (11), but here Q_S is set to 3.4 in order to insure that the currents running into the combiner is close to sine waves. MBR0560 schottky diodes are selected for the rectifier and their parasitic capacitance of 15 pF composes C_{R1} and C_{R2} . The inductor in the rectifier, L_R , is used to tune the rectifier to appear resistive at the switching frequency. Through a spice simulation the required value is found to be 350 nH. 2 μF capacitors are selected for C_{O1} and C_{O2} . A complete bill-of-material is shown in table II.

TABLE II. BILL OF MATERIAL FOR THE CONVERTER.

Component	Value
L_{I1} and L_{I2}	832 nH
C_{S1} and C_{S2}	140 pF
S_1 and S_2	EPC 8010
C_{T1} and C_{T2}	40 pF
L_{T1} and L_{T2}	355 nH
L_C	300 nH
C_C	94 pF
D_1 and D_2	MBR0560
C_{R1} and C_{R2}	(parasitic)
L_R	350 nH
C_{O1} and C_{O2}	2 μF

A spice simulation of the deigned converter has been made and the waveforms are shown in Fig. 8. From the waveforms it can be seen that the two inverters is indeed loaded equally and that ZVS is achieved across the entire input voltage range. Further more the efficiency is high and only drops below 90% for 24 V input. The reason for the reduced efficiency at this point is that the resonating currents in the inverters increase with the input voltage and hence the losses increase, at the same time the output power drops as expected from Fig. 4. The output power is kept well within the desired range with a minimum at 10 W and a peak of 14 W.

V. CONCLUSION

This paper have covered a short description of the most commonly used control methods for resonant converters operating in the very high frequency range, followed by the design and evaluation of a converter where outphasing of two inverters is used to achieve line regulation.

The designed converter achieves very good performance with equally and purely resistive loading of the two inverters across the entire input voltage range. This combined with a design of the inverters that insures that they can operate with ZVS across a wide load range, insures efficient operation of the converter across the entire input voltage range. The aim was to achieve efficient line regulation with less than +/- 20% output power variation for an input variation of +/- 30%. This is achieved as the converters keeps within +/- 16.5% output power variation. Furthermore the design exhibits very high efficiency across the entire input voltage range and only drops below 90% at the maximum input voltage.

REFERENCES

- [1] ON Semiconductor, "1.2A, 2MHz Automotive Buck Switching Regulator", NCV890100 - Datasheet, Rev. 2, February 2013
- [2] W. C. Bowman, J. F. Balicki, F. T. Dickens et al., "A resonant DC-to-DC converter operating at 22 megahertz", *IEEE Applied Power Electronics Conference and Exposition*, 1988, pp.3-11, 1-5 Feb 1988
- [3] Jingying Hu, A.D. Sagneri, J.M. Rivas, Yehui Han, S.M. Davis, D.J. Perreault, "High-Frequency Resonant SEPIC Converter With Wide Input and Output Voltage Ranges", *IEEE Transactions on Power Electronics*, vol.27, no.1, pp.189-200, Jan. 2012
- [4] J.M. Rivas, O. Leitermann, Yehui Han, D.J. Perreault, "A very high frequency dc-dc converter based on a class phi2 resonant inverter", *IEEE Transactions on Power Electronics*, 2008, vol.26, no.10, pp.2980,2992, Oct. 2011
- [5] D.J. Perreault, Jingying Hu, J.M. Rivas, Yehui Han, O. Leitermann, R.C.N. Pilawa-Podgurski, A. Sagneri, C.R. Sullivan, "Opportunities and Challenges in Very High Frequency Power Conversion", *IEEE Applied Power Electronics Conference and Exposition*, 2009, vol., no., pp.1-14, 15-19 Feb. 2009
- [6] A. Knott, T.M. Andersen, P. Kamby, M.P. Madsen, M. Kovacevic, M.A.E. Andersen, "On the ongoing evolution of very high frequency power supplies", *IEEE Applied Power Electronics Conference and Exposition 2013*, vol., no., pp.2514,2519, 17-21 March 2013
- [7] M. Madsen, A. Knott, M. A.E. Andersen, "Low Power Very High Frequency Switch-Mode Power Supply With 50 V Input and 5 V Output", *IEEE Transactions on Power Electronics*, vol. 29, no. 12, pp 6569-6080, December 2014
- [8] S. Hamamura, T. Ninomiya, M. Yamamoto, M. Katsuno, "Combined PWM and PFM control for universal line voltage of a piezoelectric transformer off-line converter," *IEEE Transactions on Power Electronics*, vol.18, no.1, pp.270,277, Jan 2003
- [9] J. M. Rivas, D. Jackson, O. Leitermann et al., "Design Considerations for Very High Frequency dc-dc Converters", *IEEE Power Electronics Specialists Conference*, 2006, vol., no., pp.1-11, 18-22 June 2006
- [10] R.C.N. Pilawa-Podgurski, A.D. Sagneri, J.M. Rivas, D.I. Anderson, D.J. Perreault, "Very-High-Frequency Resonant Boost Converters", *IEEE Transactions on Power Electronics*, vol.24, no.6, pp.1654,1665, June 2009
- [11] Jingying Hu, A.D. Sagneri, J.M. Rivas, Yehui Han, S.M. Davis, D.J. Perreault, "High-Frequency Resonant SEPIC Converter With Wide Input and Output Voltage Ranges", *IEEE Transactions on Power Electronics*, vol.27, no.1, pp.189,200, Jan. 2012

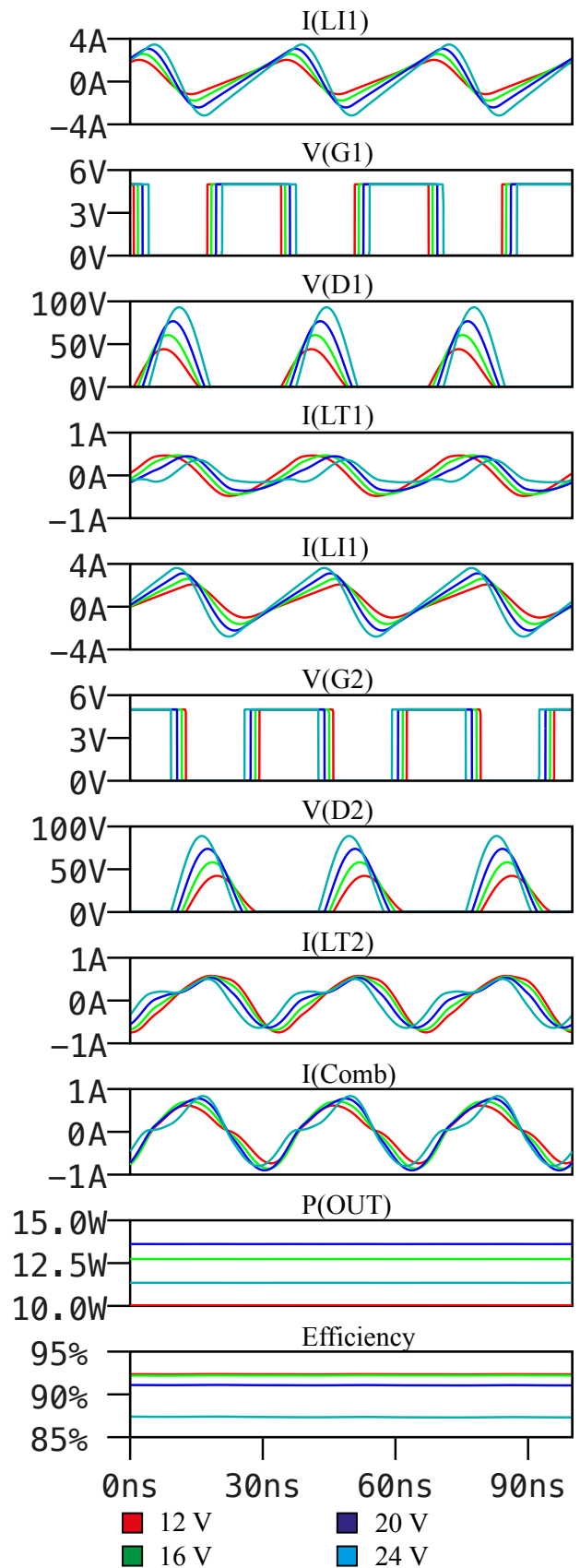

Fig. 8. Waveforms of the converter when controlled with outphasing.

- [12] M. Kovacevic, A. Knott, M. A.E. Andersen, "A VHF interleaved self-oscillating resonant SEPIC converter with phase-shift burst-mode control," *Applied Power Electronics Conference and Exposition (APEC), 2014 Twenty-Ninth Annual IEEE*, vol., no., pp.1402,1408, 16-20 March 2014
- [13] H. Chireix, "High power outphasing modulation," *Proc. IRE*, vol. 23, no. 11, pp. 1370–1392, Nov. 1935.
- [14] A.S. Jurkov, L. Roslaniec, D.J. Perreault, "Lossless Multiway Power Combining and Outphasing for High-Frequency Resonant Inverters," *IEEE Transactions on Power Electronics*, vol.29, no.4, pp.1894,1908, April 2014
- [15] Godoy, P.A.; Perreault, D.J.; Dawson, J.L., "Outphasing Energy Recovery Amplifier With Resistance Compression for Improved Efficiency," *IEEE Transactions on Microwave Theory and Techniques*, vol.57, no.12, pp.2895,2906, Dec. 2009
- [16] F. H. Raab, "Efficiency of outphasing RF power-amplifier systems," *IEEE Trans. Commun.*, vol. 33, no. 10, pp. 1094–1099, Oct. 1985.
- [17] A. Birafane and A. Kouki, "On the linearity and efficiency of outphasing microwave amplifiers," *IEEE Trans. Microw. Theory Tech.*, vol. 52, no. 7, pp. 1702–1708, Jul. 2004.
- [18] J. Yao and S. I. Long, "Power amplifier selection for LINC applications," *IEEE Trans. Circuits Syst. II, Exp. Briefs*, vol. 53, no. 8, pp. 763–767, Aug. 2006.
- [19] F. H. Raab, P. Asbeck, S. Cripps, P. B. Kennington, Z. B. Popovich, N. Pothecary, J. F. Sevic, and N. O. Sokal, "RF and microwave power amplifier and transmitter technologies—Part 3," *High-Frequency Electron.*, pp. 34–48, Sep. 2003.
- [20] D. J. Perreault, "A New Power Combining and Outphasing Modulation System for High-Efficiency Power Amplification," *IEEE Transactions on Circuits and Systems I: Regular Papers*, vol.58, no.8, pp.1713,1726, Aug. 2011
- [21] M.P. Madsen, A. Knott and M.A.E. Andersen, "Very High Frequency Half Bridge DC/DC Converter", *IEEE Applied Power Electronics Conference and Exposition 2014*
- [22] L. Roslaniec, D. J. Perreault, "Design of variable-resistance class E inverters for load modulation," *2012 IEEE Energy Conversion Congress and Exposition (ECCE)*, vol., no., pp.3226,3232, 15-20 Sept. 2012

