

(12) **United States Patent**
Perreault

(10) **Patent No.:** **US 8,830,709 B2**
(45) **Date of Patent:** **Sep. 9, 2014**

(54) **TRANSMISSION-LINE RESISTANCE
COMPRESSION NETWORKS AND RELATED
TECHNIQUES**

(71) Applicant: **Eta Devices, Inc.**, Cambridge, MA (US)

(72) Inventor: **David J. Perreault**, Brookline, MA (US)

(73) Assignee: **Eta Devices, Inc.**, Cambridge, MA (US)

(*) Notice: Subject to any disclaimer, the term of this patent is extended or adjusted under 35 U.S.C. 154(b) by 0 days.

(21) Appl. No.: **13/800,221**

(22) Filed: **Mar. 13, 2013**

(65) **Prior Publication Data**

US 2013/0343107 A1 Dec. 26, 2013

Related U.S. Application Data

(62) Division of application No. 13/755,335, filed on Jan. 31, 2013.

(60) Provisional application No. 61/663,930, filed on Jun. 25, 2012.

(51) **Int. Cl.**

H02J 1/10 (2006.01)
H03H 7/38 (2006.01)
H02M 7/06 (2006.01)
H02M 7/217 (2006.01)
H03F 3/00 (2006.01)

(52) **U.S. Cl.**

CPC . **H03H 7/38** (2013.01); **H02M 7/06** (2013.01);
H02M 7/217 (2013.01); **H03F 3/00** (2013.01)
USPC **363/65**

(58) **Field of Classification Search**

CPC H02M 7/217; H03H 7/38
USPC 363/65, 67, 69
See application file for complete search history.

(56) **References Cited**

U.S. PATENT DOCUMENTS

4,319,359 A 3/1982 Wolf
5,568,088 A 10/1996 Dent et al.

(Continued)

FOREIGN PATENT DOCUMENTS

GB 1506633 4/1978
WO 0067373 11/2000

(Continued)

OTHER PUBLICATIONS

PCT Search Report of the ISA for PCT/US2013/046747 dated Jan. 31, 2014.

(Continued)

Primary Examiner — Matthew Nguyen

(74) *Attorney, Agent, or Firm* — Daly, Crowley, Mofford & Durkee, LLP

(57) **ABSTRACT**

A resistance compression network to shape an input impedance at a port for transferring energy to multiple loads at a first frequency includes first and second transmission line segments having outputs for coupling to first and second loads and having different electrical lengths at a first frequency and a compression port coupled to inputs of both the first and the second transmission line segments. Over a set of operating conditions of interest, an equivalent resistance looking into the compression port at the frequency varies over a first resistance range as equivalent resistances of the first and second loads vary over a second resistance range and a range ratio associated with the first resistance range is less than a range ratio associated with the second resistance range and the range ratio of a subject range is a ratio of a largest resistance value in the subject range to a smallest resistance value in the subject range.

18 Claims, 16 Drawing Sheets

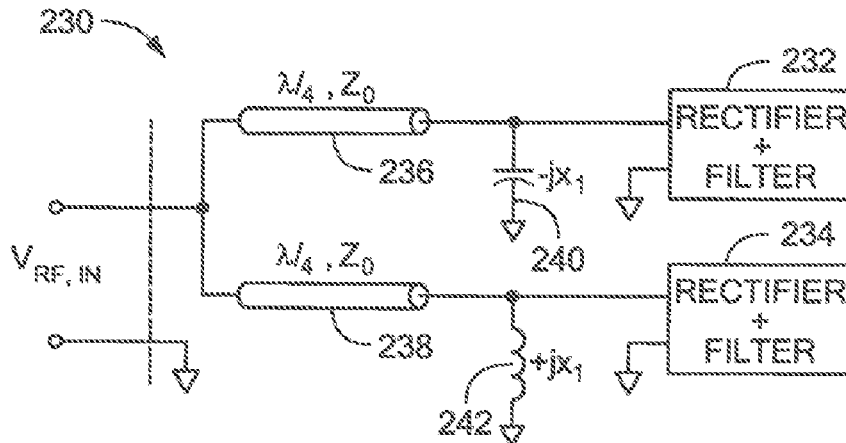

(56)

References Cited

U.S. PATENT DOCUMENTS

5,638,024	A	6/1997	Dent et al.	
5,708,573	A	1/1998	Lusher et al.	
5,736,877	A *	4/1998	Tihanyi	327/77
5,892,395	A	4/1999	Stengel et al.	
6,600,384	B2	7/2003	Mohwinkel et al.	
6,887,339	B1	5/2005	Goodman et al.	
7,279,971	B2	10/2007	Hellberg et al.	
7,508,262	B1	3/2009	Wagner et al.	
7,535,133	B2	5/2009	Perreault et al.	
7,589,605	B2	9/2009	Perreault et al.	
7,889,519	B2	2/2011	Perreault et al.	
7,956,572	B2	6/2011	Zane et al.	
8,026,763	B2	9/2011	Dawson et al.	
8,164,384	B2	4/2012	Dawson et al.	
8,212,541	B2	7/2012	Perreault et al.	
8,451,053	B2	5/2013	Perreault et al.	
8,638,156	B2 *	1/2014	Shibata et al.	327/308
2004/0027209	A1	2/2004	Chen et al.	
2006/0193095	A1	8/2006	Hunter et al.	
2009/0200985	A1	8/2009	Zane et al.	
2011/0187437	A1	8/2011	Perreault et al.	
2011/0215866	A1	9/2011	Dawson et al.	
2012/0176195	A1	7/2012	Dawson et al.	
2012/0313602	A1	12/2012	Perreault et al.	
2012/0326684	A1	12/2012	Perreault et al.	
2013/0241625	A1	9/2013	Perreault et al.	
2013/0343106	A1	12/2013	Perreault et al.	

FOREIGN PATENT DOCUMENTS

WO	WO 01/10013	A1	2/2001
WO	WO 2005/106613	A1	11/2005
WO	WO 2006/119362	A2	11/2006
WO	WO 2007/082090	A2	7/2007
WO	WO 2007/094921	A1	8/2007
WO	WO 2010/056646	A1	5/2010
WO	WO 2011/097387	A1	8/2011
WO	WO 2013/109719	A1	7/2013
WO	WO 2013/109743	A2	7/2013
WO	WO 2013/109797	A1	7/2013
WO	WO 2013/134573	A1	9/2013
WO	WO 2013/191757	A1	12/2013
WO	WO 2014/004241	A2	1/2014
WO	WO 2014/028441	A2	2/2014

OTHER PUBLICATIONS

PCT Written Opinion of the ISA for PCT/US2013/046747 dated Jan. 31, 2014.

Beltran, et al.; "An Outphasing Transmitter Using Class-E PAs and Asymmetric Combining: Part 1;" High Frequency Electronics; Summit Technical Media, LLC; Apr. 2011; pp. 18-26.

Beltran, et al.; "An Outphasing Transmitter Using Class-E PAs and Asymmetric Combining: Part 2;" High Frequency Electronics; Summit Technical Media, LLC; May 2011; pp. 34-46.

Chang, et al.; "A Power-Recycling Technique for Improving Power Amplifier Efficiency Under Load Mismatch;" IEEE Microwave and Wireless Components Letters; vol. 21; No. 10; Oct. 2011; pp. 571-873.

Eun, et al.; "A High Linearity Chireix Outphasing Power Amplifier Using Composite Right/Left-Handed Transmission Lines;" Proceedings of the 4th European Radar Conference; Oct. 2007; pp. 343-346.

Gerhard, et al.; "Novel Transmission Line Combiner for High Efficient Outphasing RF Power Amplifiers;" Proceedings of the 37th European Microwave Conference; Oct. 2007; pp. 1433-1436.

Godoy, et al.; "Outphasing Energy Recovery Amplifier with Resistance Compression for Improved Efficiency;" IEEE Transactions on Microwave Theory and Techniques; vol. 57; No. 12; Dec. 2009; pp. 2895-2906.

Gutmann, et al.; "Power Combining in an Array of Microwave Power Rectifiers;" IEEE Microwave Symposium Digest; Apr. 30, 1979-May 2, 1979; pp. 453-455.

Han, et al.; "Resistance Compression Networks for Radio-Frequency Power Conversion;" IEEE Transactions on Power Electronics; vol. 22; No. 1; Jan. 2007; pp. 41-53.

Langridge, et al.; "A Power Re-Use Technique for Improved Efficiency of Outphasing Microwave Power Amplifiers;" IEEE Transactions on Microwave Theory and Techniques; vol. 47; No. 8; Aug. 1999; pp. 1467-1470.

Nitz, et al.; "A New Family of Resonant Rectifier Circuits for High Frequency DC-DC Converter Applications;" Applied Power Electronics Conference and Exposition; 1988; APEC 88; Conference Proceedings 1988; Feb. 1-5, 1988; pp. 12-22.

Paing, et al.; "Resistor Emulation to Low-Power RF Energy Harvesting;" IEEE Transactions on Power Electronics; vol. 23; No. 3; May 2008; pp. 1494-1501.

Perreault; "A New Power Combining and Outphasing Modulation System for High-Efficiency Power Amplification;" IEEE Transactions on Circuits and System-I: Regular Papers; vol. 58; No. 8; Aug. 2011; pp. 1713-1726.

Rivas, et al.; "New Architecture for Radio Frequency dc/dc/ Power Conversion;" 2004 35th Annual IEEE Power Electronics Specialist Conference; Aachen, German; vol. 15; Jun. 2004; pp. 4074-4084.

International Search Report and Written Opinion of the ISA for PCT/US2006/016981 dated Dec. 29, 2006.

U.S. Appl. No. 13/755,335, filed Jan. 31, 2013.

Office Action dated Feb. 25, 2014 from U.S. Appl. No. 13/755,335.

Response to Office Action dated Feb. 14, 2014 as filed on May 21, 2014 for U.S. Appl. No. 13/755,335.

Notice of Allowance for U.S. Appl. No. 13/755,335, filed Jan. 31, 2013.

* cited by examiner

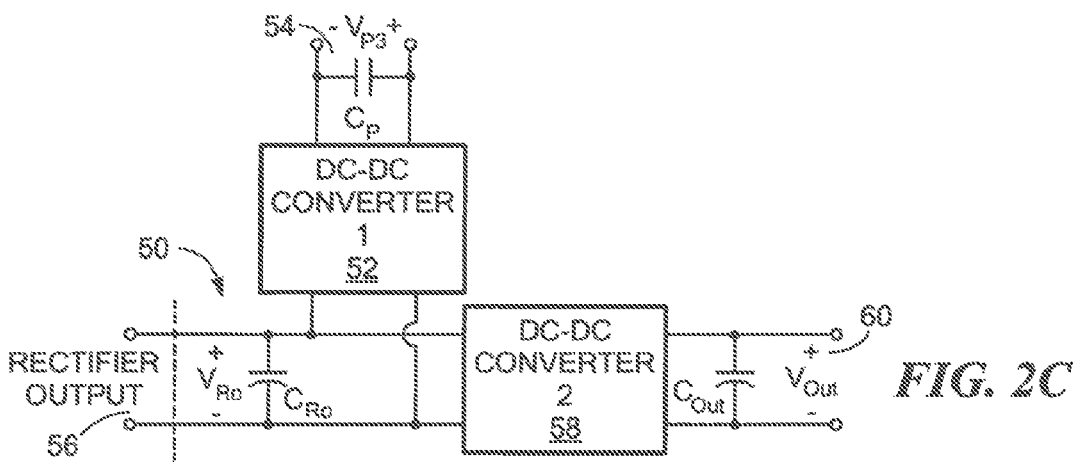
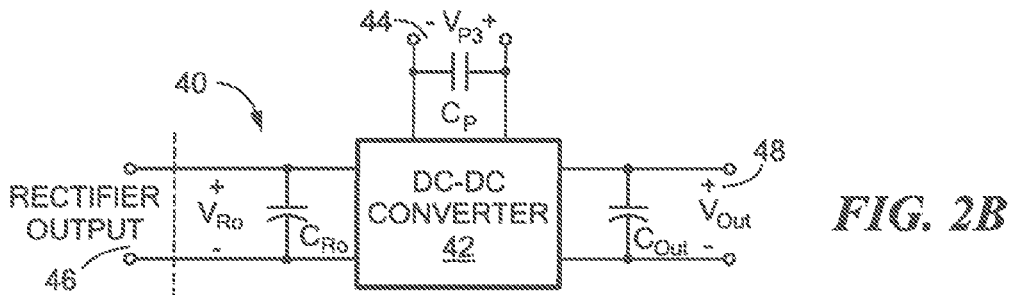
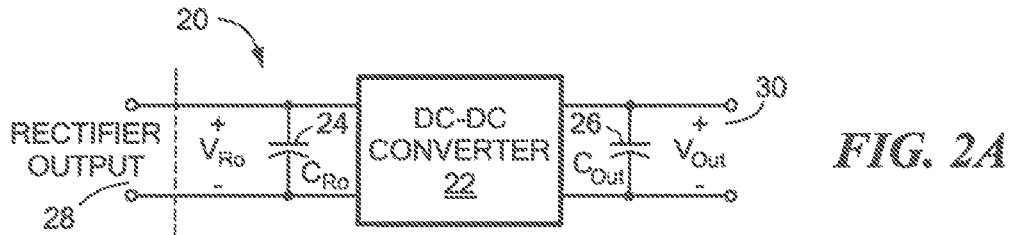
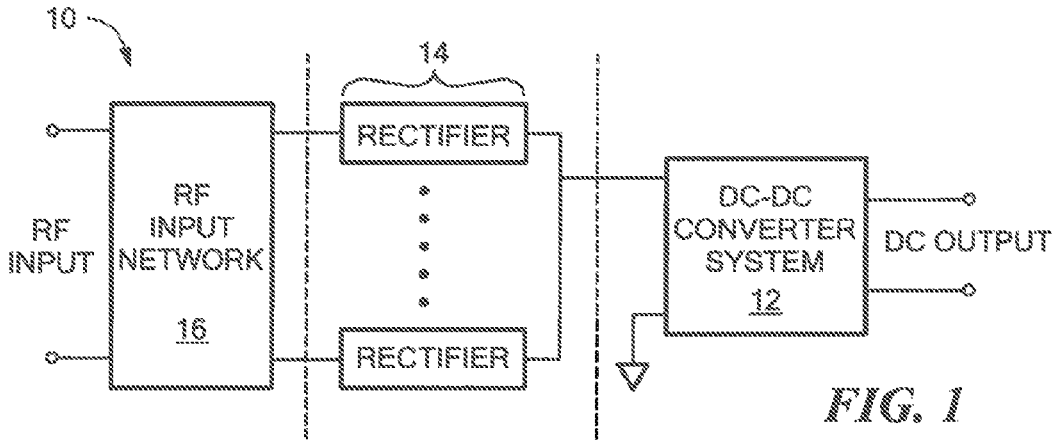

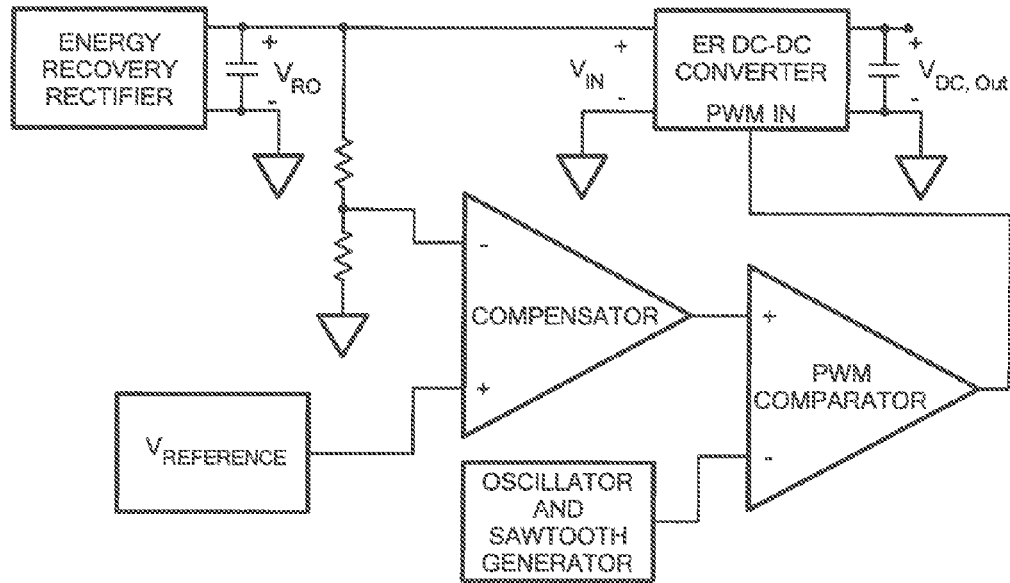

FIG. 2D

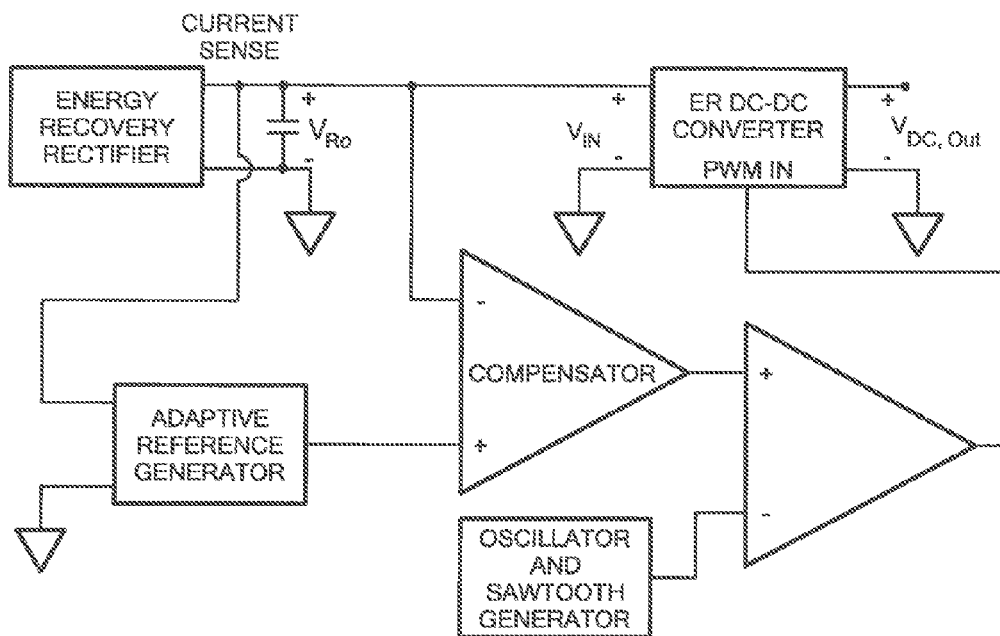

FIG. 2E

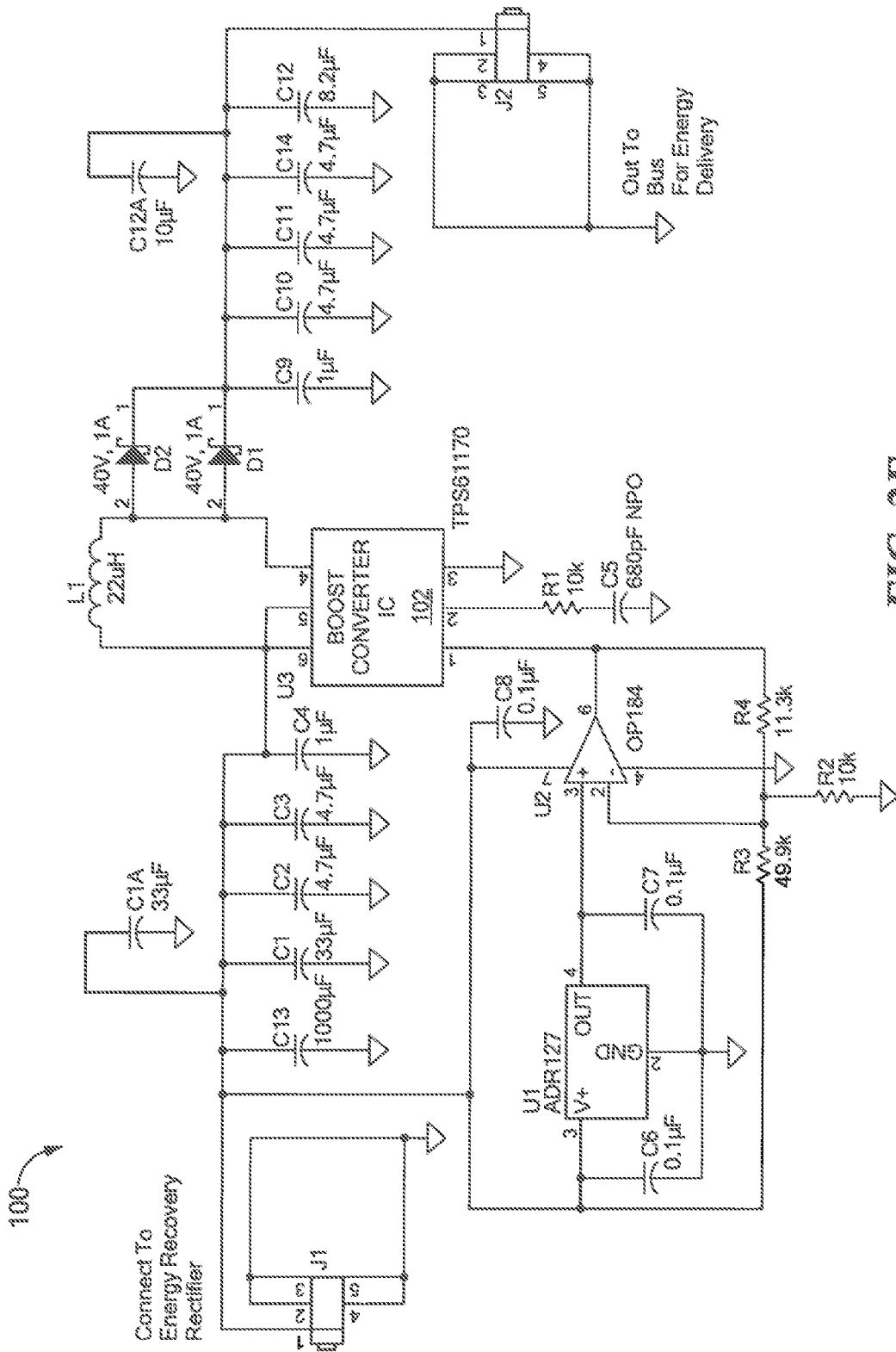

FIG. 2F

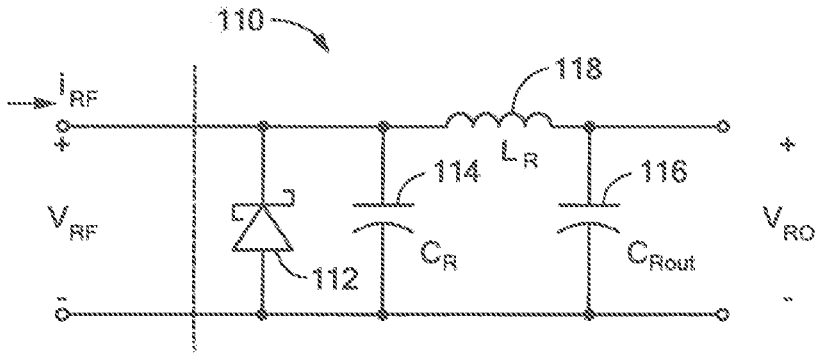

FIG. 3A

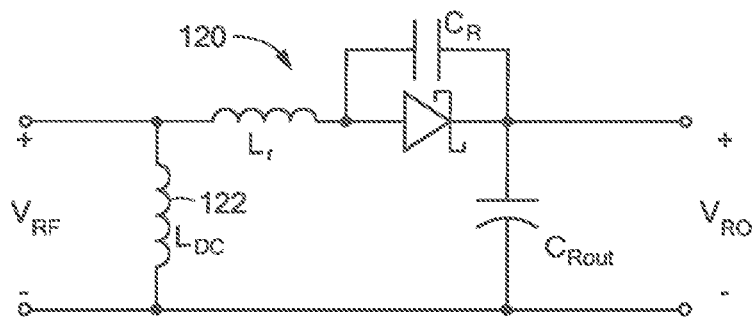

FIG. 3B

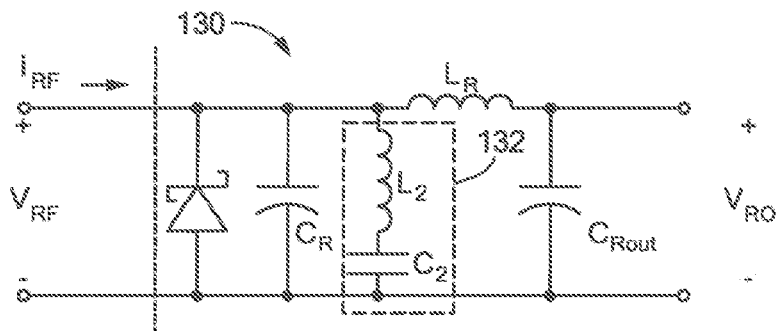

FIG. 3C

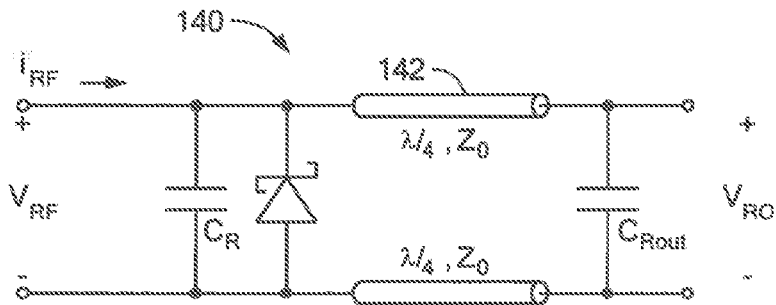

FIG. 3D

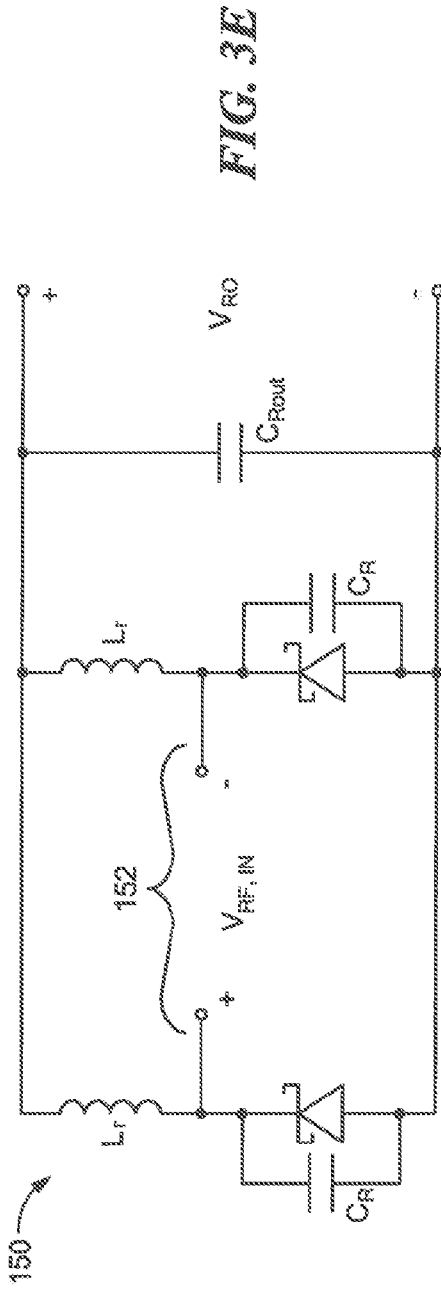

FIG. 3E

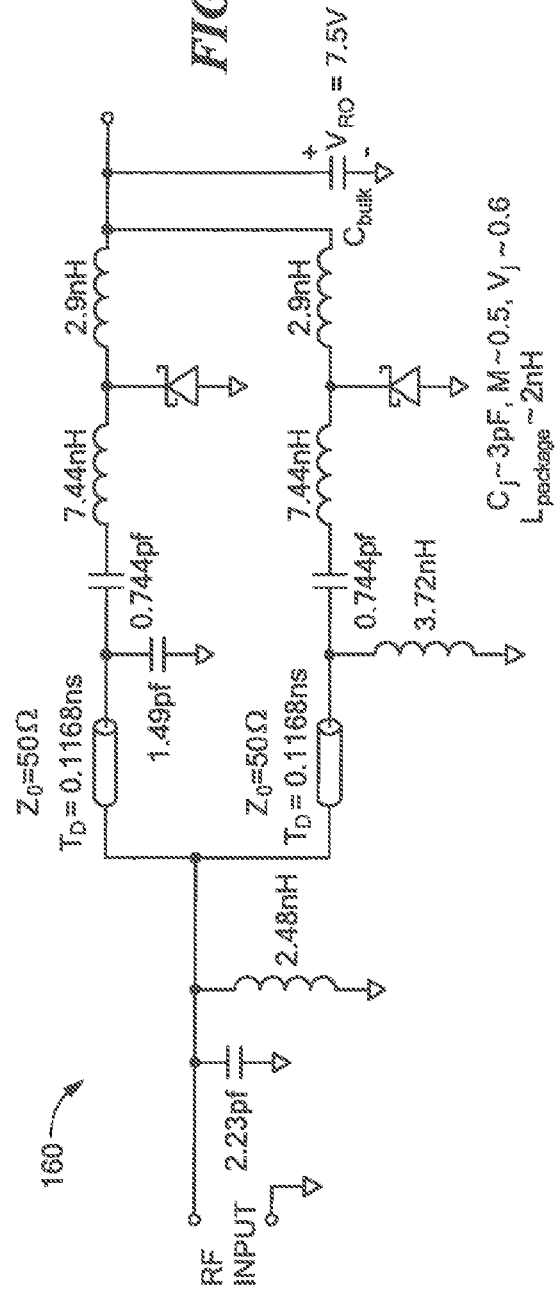

FIG. 3F

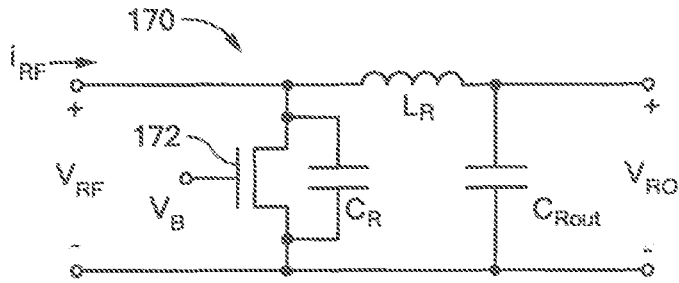

FIG. 4A

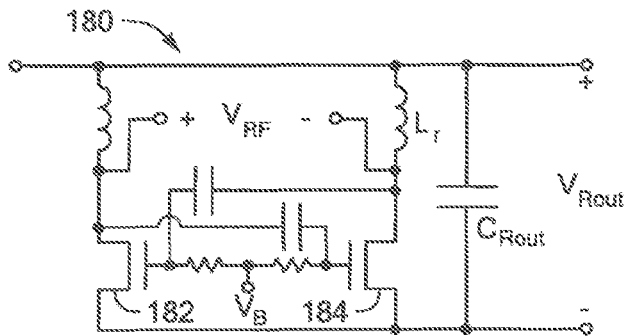

FIG. 4B

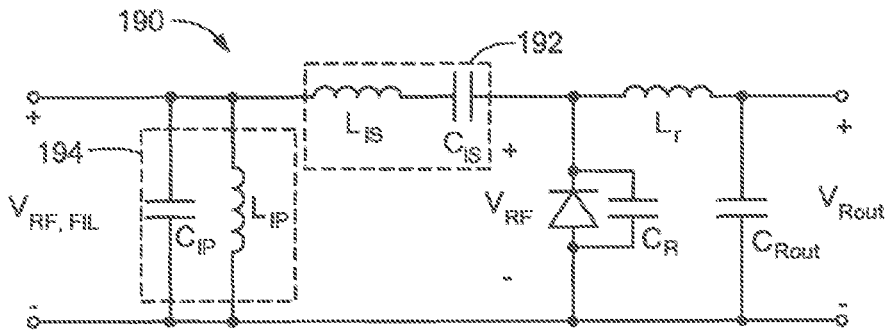

FIG. 5

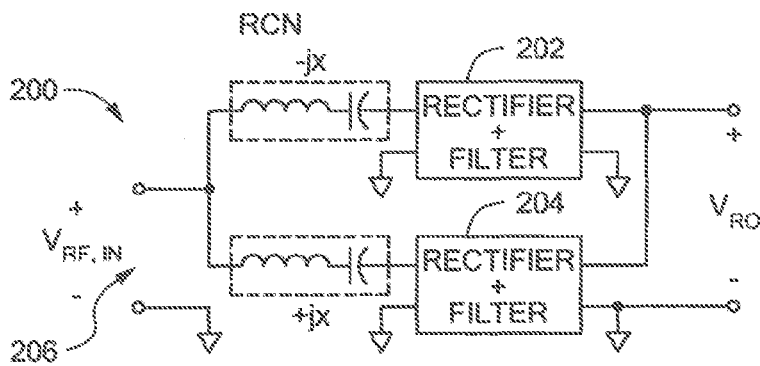

FIG. 6A

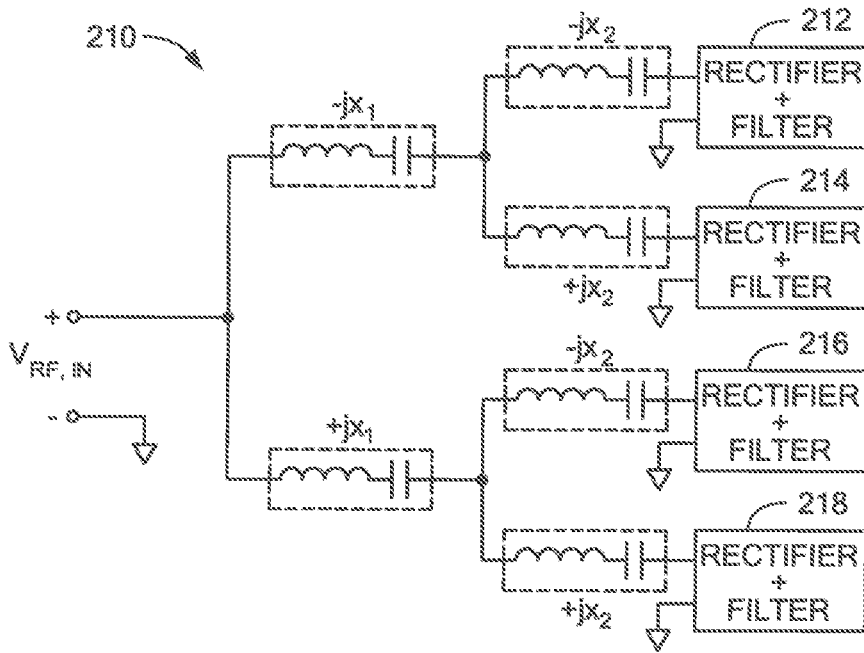

FIG. 6B

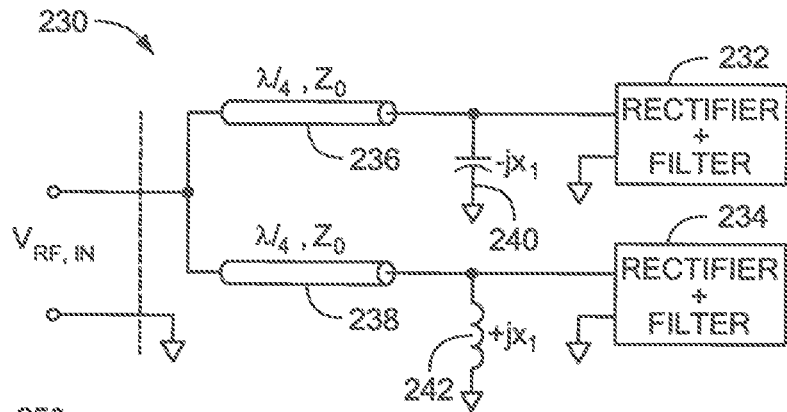

FIG. 6C

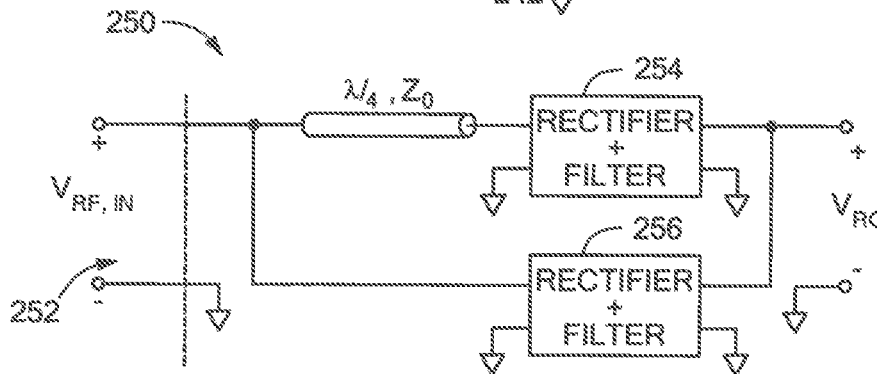

FIG. 6D

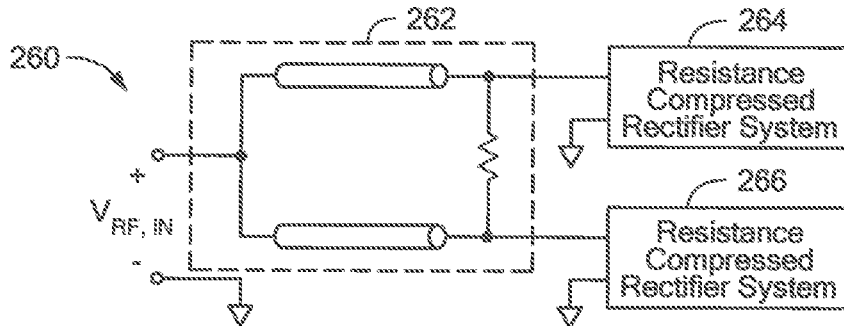

FIG. 6E

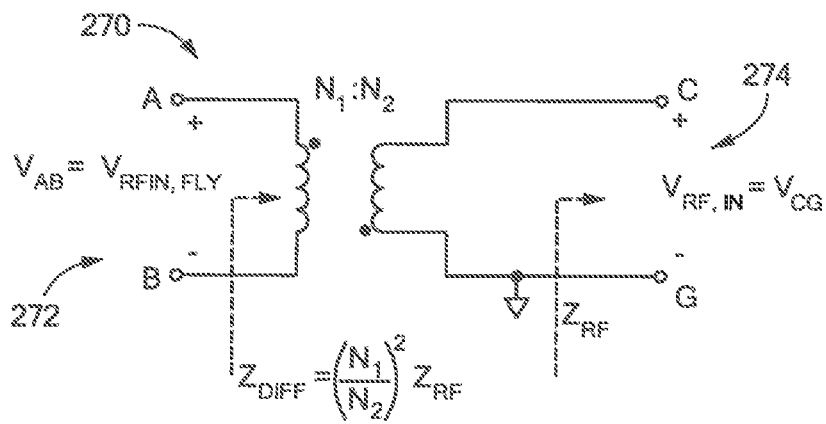

FIG. 7A

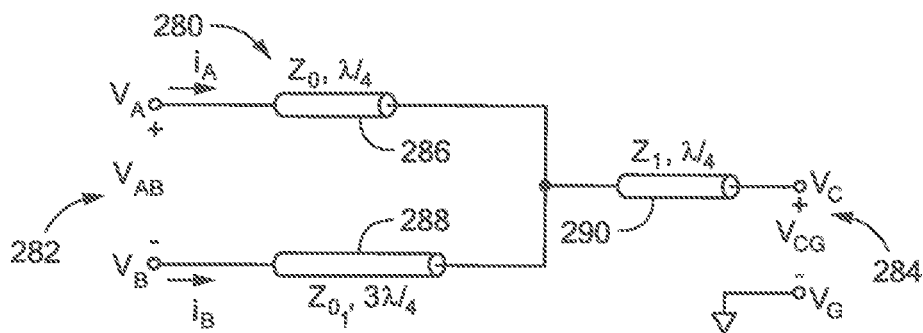

FIG. 7B

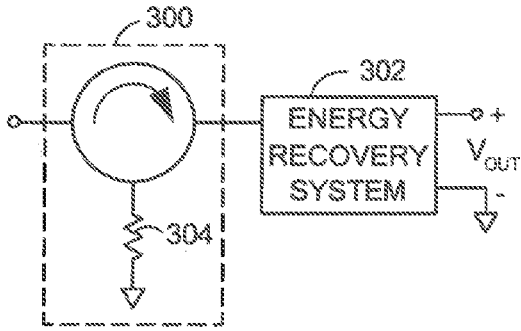

FIG. 8A

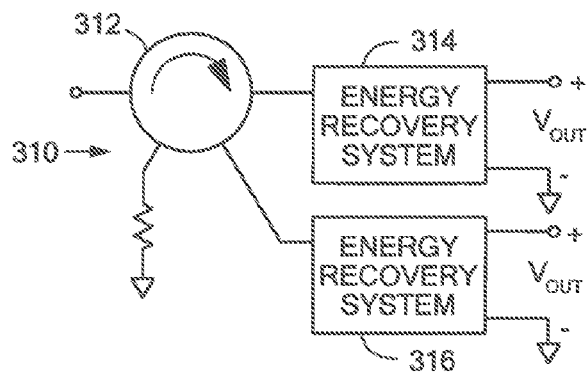

FIG. 8B

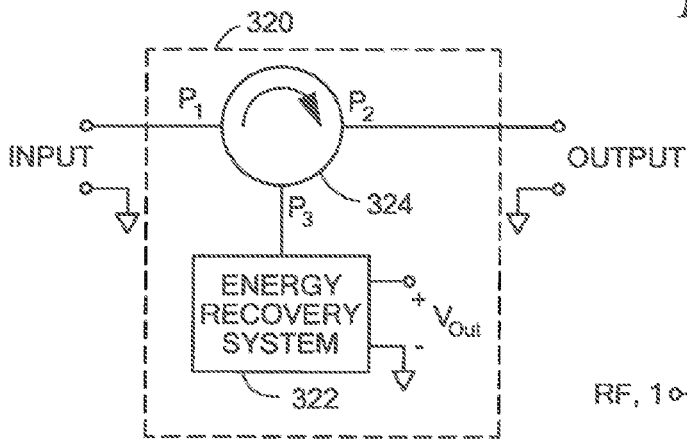

FIG. 9A

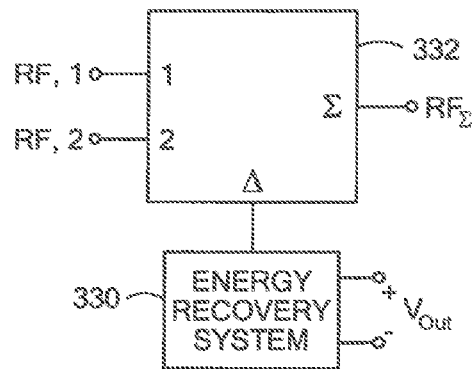
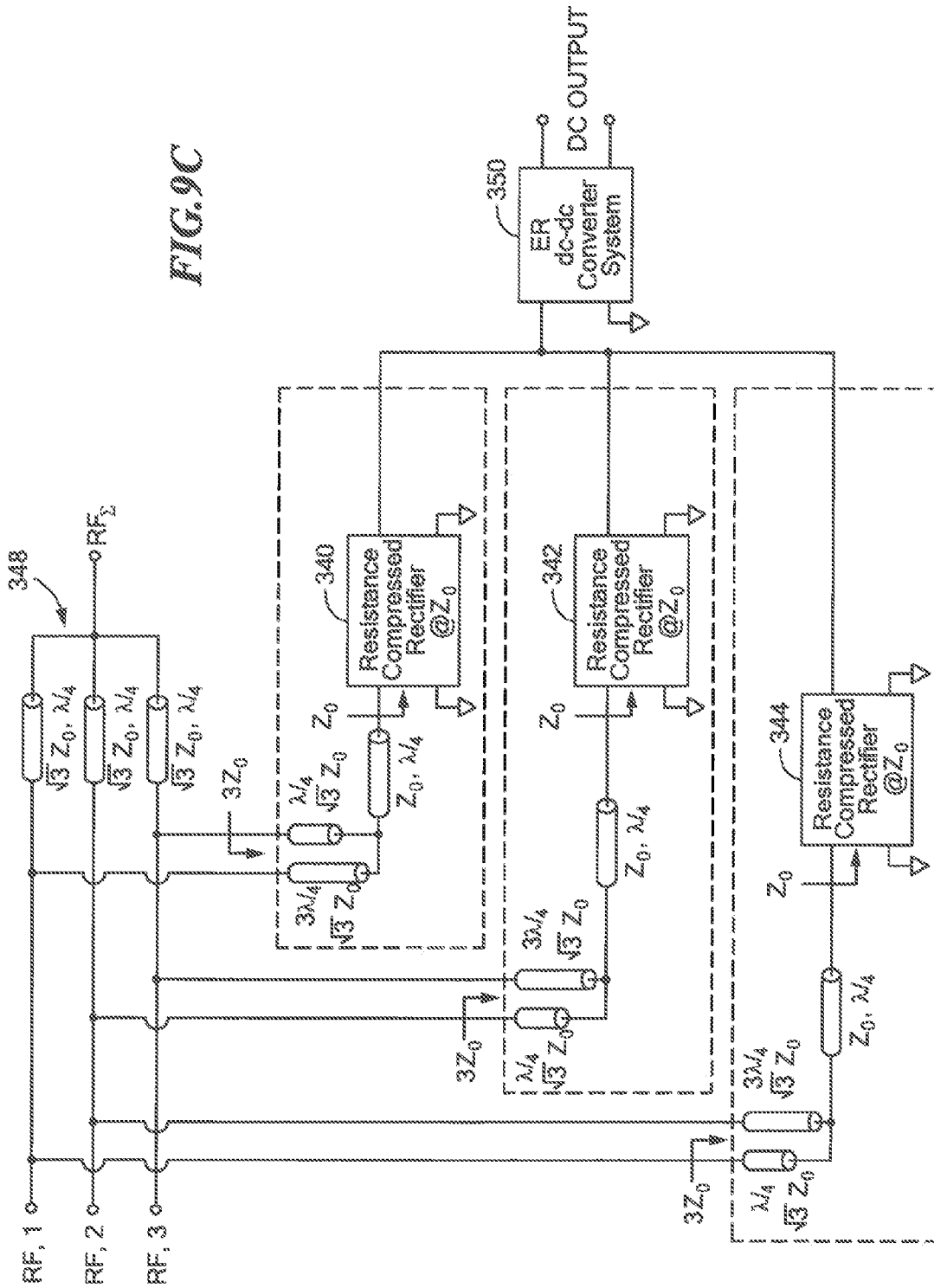
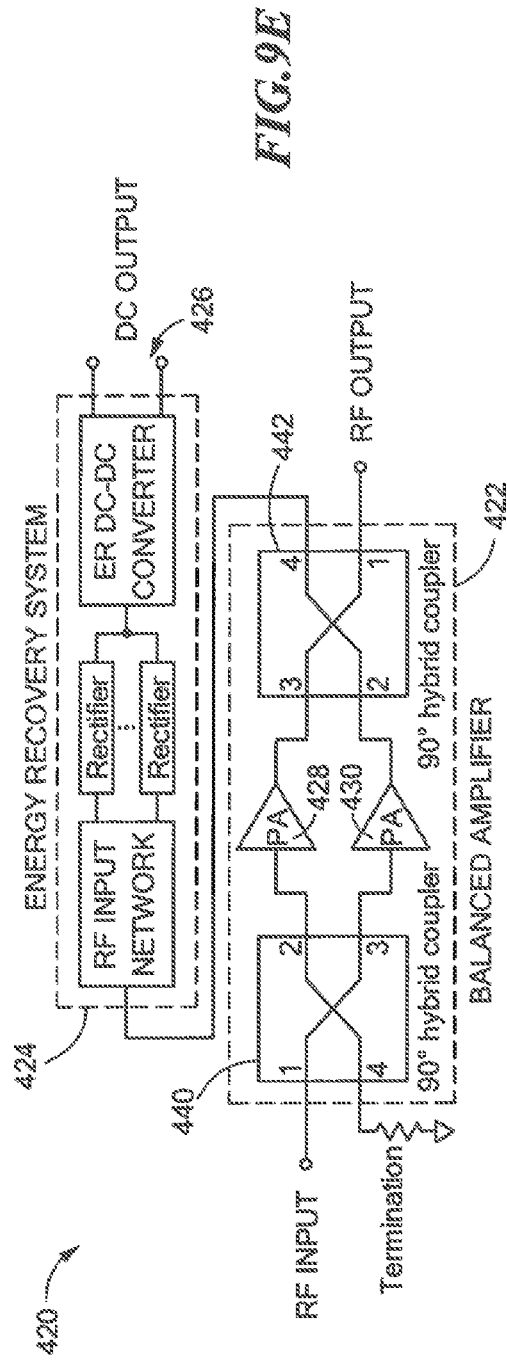
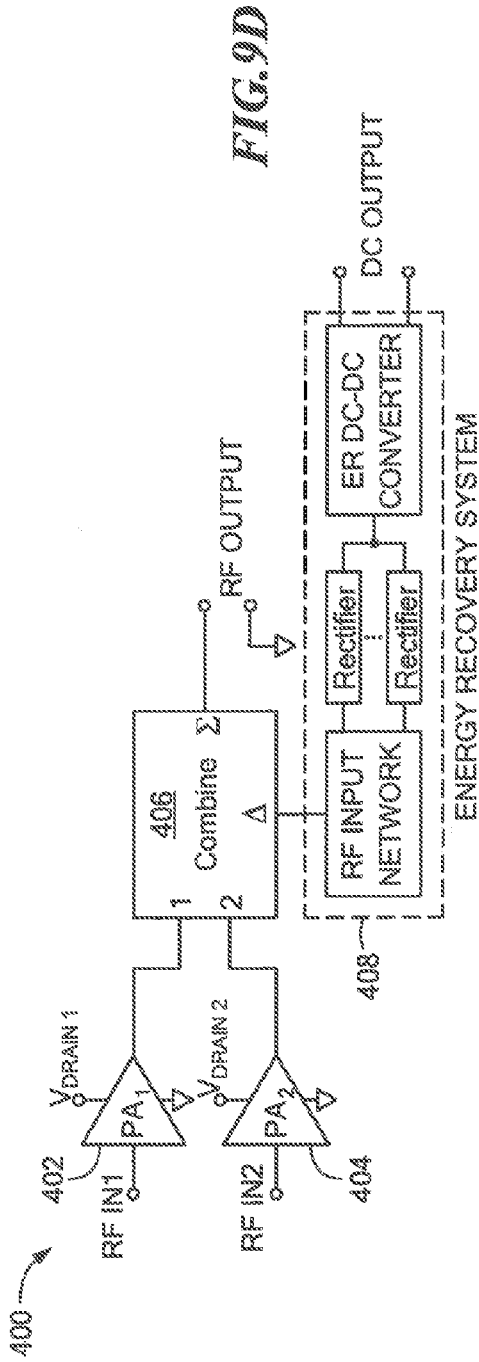

FIG. 9B

FIG. 9C





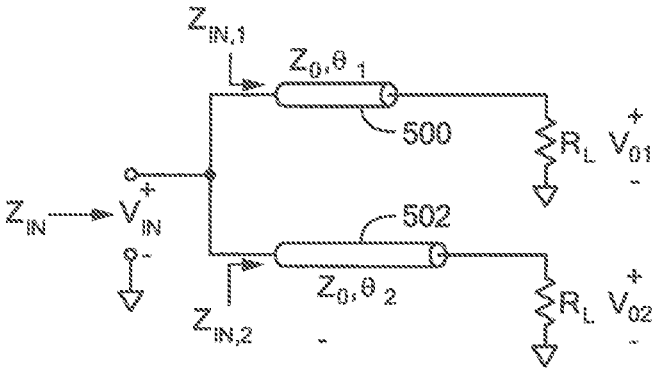

FIG. 10A

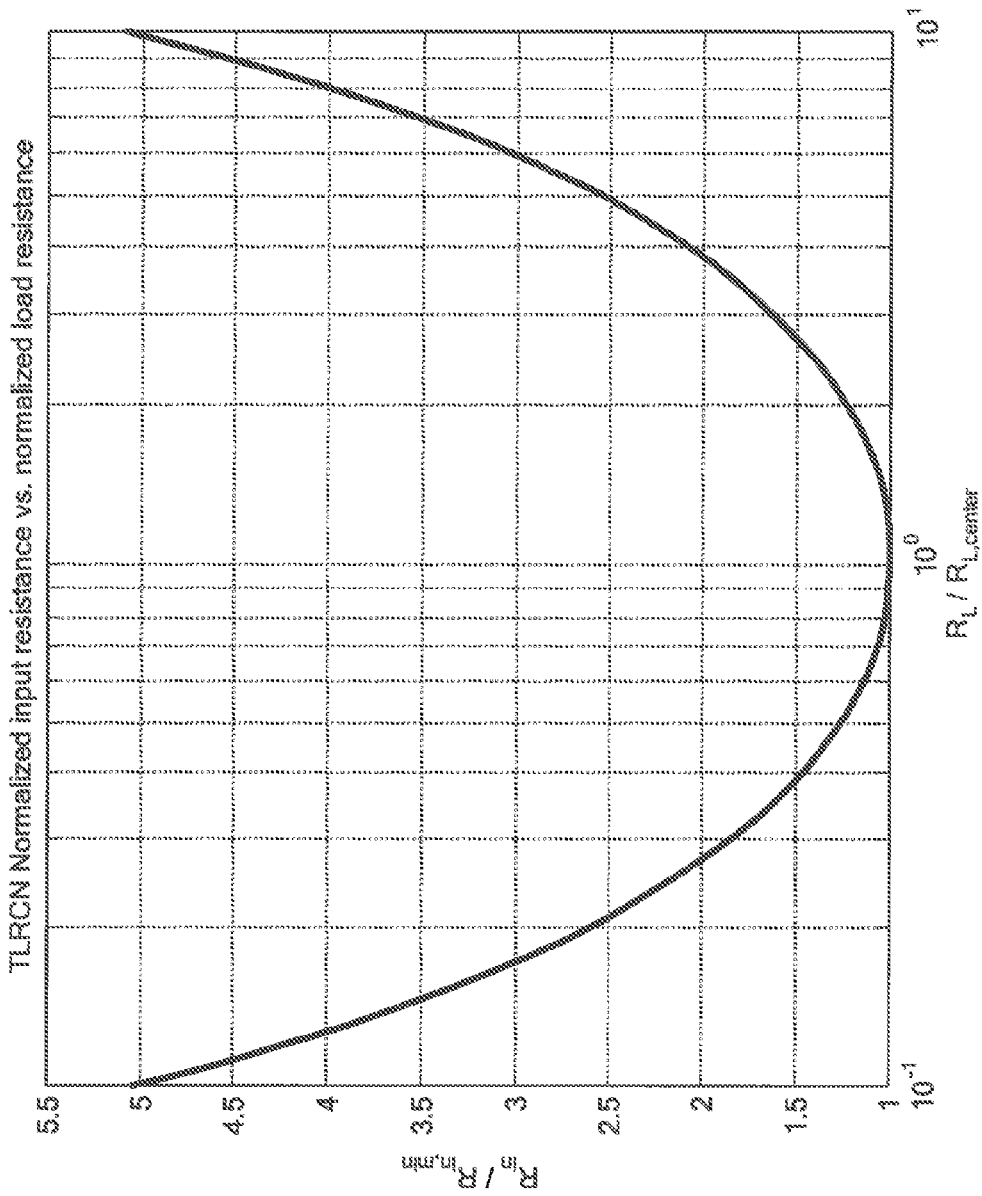

FIG. 10B

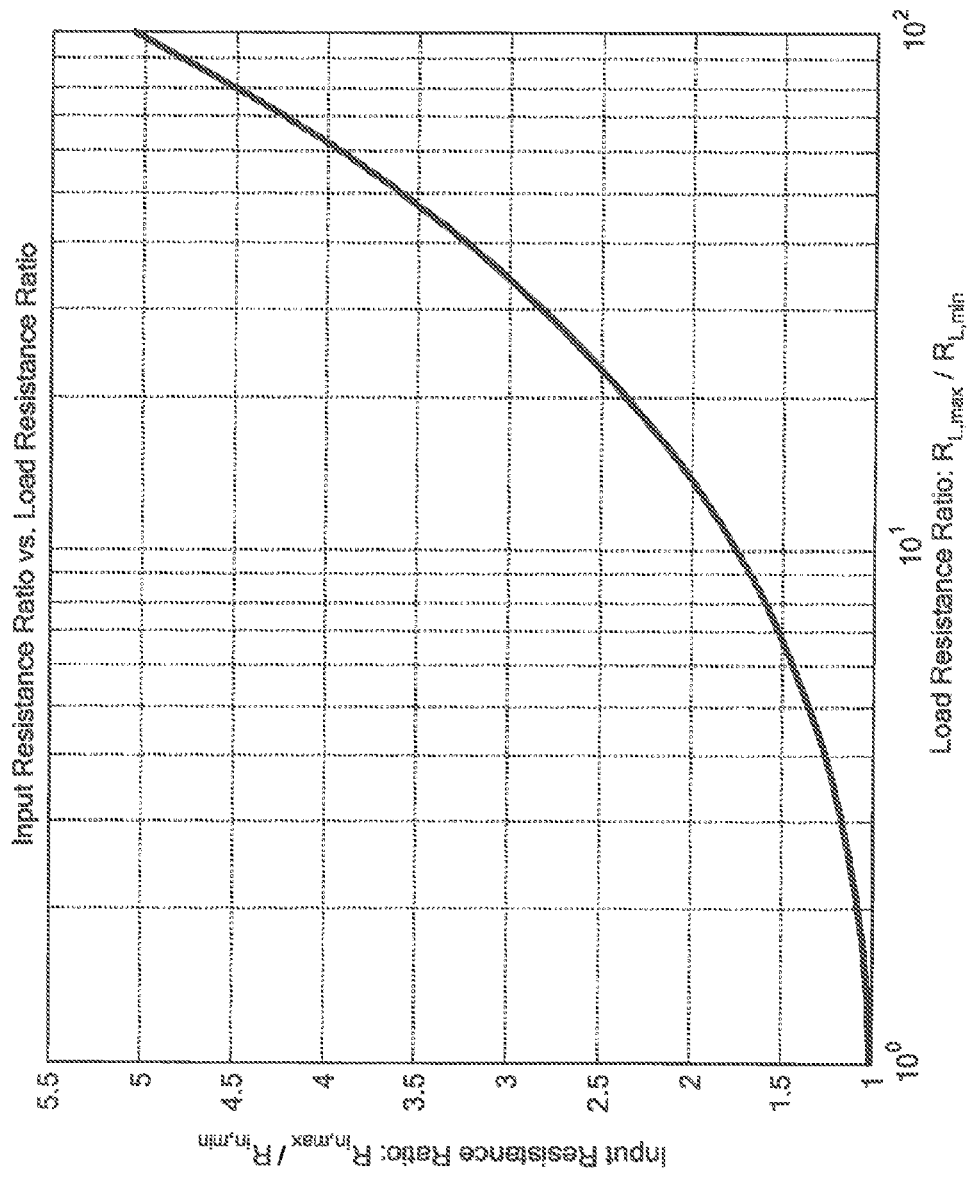

FIG. 10C

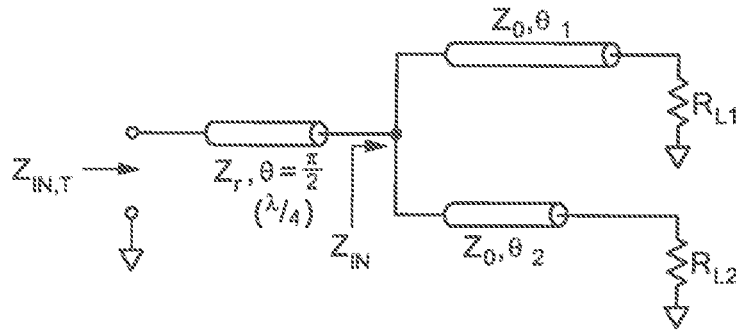

FIG. 10D

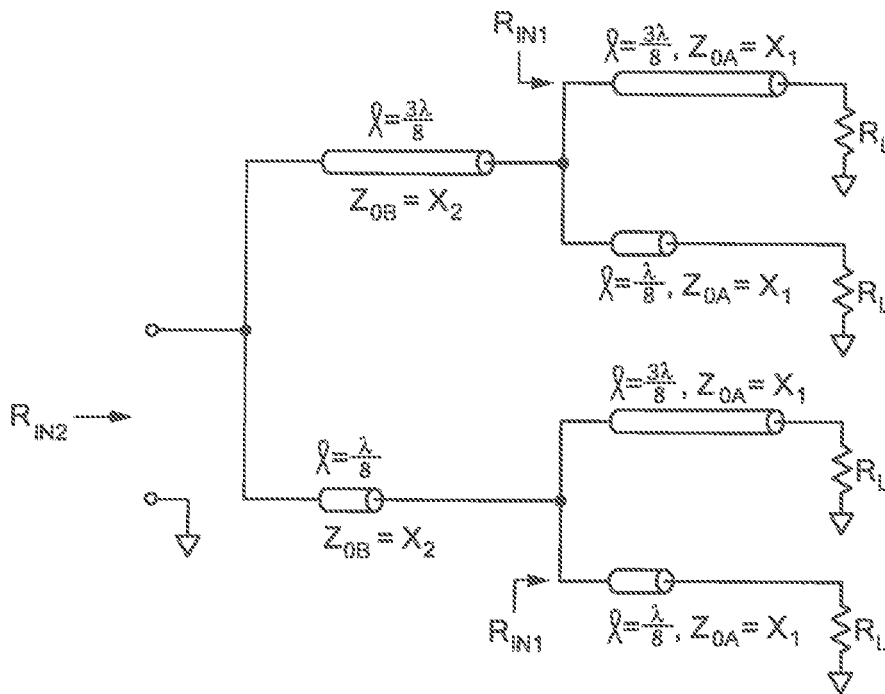

FIG. 10E

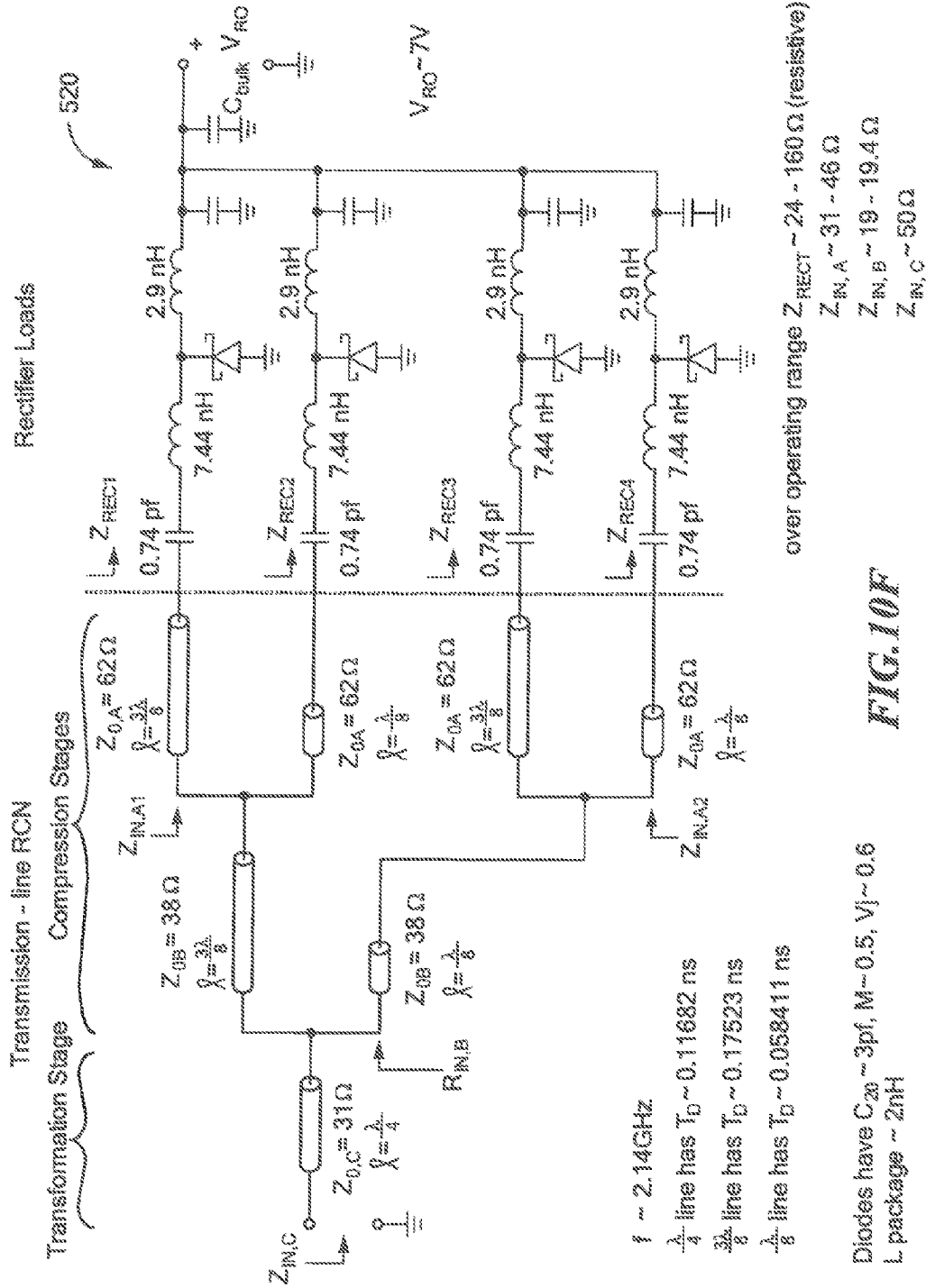

FIG. 10F

1

TRANSMISSION-LINE RESISTANCE COMPRESSION NETWORKS AND RELATED TECHNIQUES

CROSS REFERENCE TO RELATED APPLICATIONS

This application is a divisional application of U.S. application Ser. No. 13/755,335, filed Jan. 31, 2013, which claims the benefit of U.S. Provisional Application No. 61/663,930, filed Jun. 25, 2012, which applications are hereby incorporated by reference in their entireties.

FIELD

Subject matter disclosed herein relates generally to radio frequency (RF) systems and, more particularly, to techniques and circuits for shaping the input impedance of one or more load devices in an RF system.

BACKGROUND

In many applications, there is a need to reduce a range over which an input resistance varies. For example, in an energy recovery system that uses a plurality of tuned rectifier circuits to convert an RF signal to DC, there may be a need to compress a resistance range looking into the various rectifier circuits into a smaller range. The compressed resistance may then be presented to an RF circuit as a resistive termination. In such applications, a resistance compression network may be provided to perform the compression. Some examples of resistance compression networks are described in U.S. Pat. No. 7,535,133 to Perreault et al., which is hereby incorporated by reference herein in its entirety.

As with most circuits and systems, it is generally desirable that resistance compression networks be relatively simple and inexpensive to fabricate. In addition, it is generally desirable that resistance compression networks have relatively low loss. It may also be desirable that such networks be capable of performing other functions in addition to resistance compression. As such, there is a need for resistance compression networks that are capable of providing some or all of these attributes.

SUMMARY

Resistance compression networks and techniques are described herein that use transmission line segments having asymmetric lengths to reduce a range over which the input resistances of a plurality of loads vary. The resistance compression networks are capable of being easily and inexpensively fabricated using printed circuit techniques. In addition, the resistance compression networks are capable of lossless or near lossless operation in some implementations. In some embodiments, the resistance compression networks may be adapted to provide filtration functions in addition to resistance compression. Also, in some embodiments, the resistance compression networks may be adapted to reduce the degree to which an input immittance of a resistance compression network appears susceptible as compared to the immittance of a plurality of loads. Multi-stage transmission line resistance compression networks may be provided in some implementations to generate a higher level of compression. In general, the transmission line resistance compression networks described herein may provide resistance compression at a fundamental frequency. In some embodiments, however,

2

transmission line segment lengths may be selected in a manner that also provides compression at one or more harmonic frequencies.

In accordance with one aspect of the concepts, systems, circuits, and techniques described herein, a resistance compression network is provided to shape an input impedance at a port for transferring energy to multiple loads at a first frequency. More specifically, the resistance compression network comprises: a first transmission line segment having a first electrical length at the first frequency, the first transmission line segment having an output for coupling to a first load; a second transmission line segment having a second electrical length at the first frequency, the second electrical length being different from the first electrical length, the second transmission line segment having an output for coupling to a second load; and a compression port coupled to inputs of both the first and the second transmission line segments; wherein, over a set of operating conditions of interest, an equivalent resistance looking into the compression port at the first frequency varies over a first resistance range as equivalent resistances of the first and second loads vary over a second resistance range, wherein a range ratio associated with the first resistance range is less than a range ratio associated with the second resistance range, wherein the range ratio of a subject range is a ratio of a largest resistance value in the subject range to a smallest resistance value in the subject range.

In accordance with another aspect of the concepts, systems, circuits, and techniques described herein, a circuit comprises: first and second loads having substantially the same input impedances under substantially the same operating conditions; and a transmission-line resistance compression network, including: an input port; a first output port coupled to the first load; a second output port coupled to the second load; and a transmission-line network coupled to the input port, the first output port, and the second output port, the transmission-line network comprising at least two transmission lines of different lengths; wherein, for a first operating range, the resistances at input ports of the first and second loads vary over first and second ratios, respectively, the resistance of the input impedance at the input port of the transmission-line compression network varies over a third ratio, and the third ratio is smaller than at least one of the first and second ratios.

In accordance with still another aspect of the concepts, systems, circuits, and techniques described herein, a method is provided for compressing resistances associated with a plurality of loads. More specifically, the method comprises: transforming an input impedance of a first load using a first transmission line segment having a first electrical length at a first frequency, the first load being associated with a first resistance range at the first frequency; transforming an input impedance of a second load using a second transmission line segment having a second electrical length at the first frequency, the second load being associated with a second resistance range at the first frequency; and providing a compressed resistance range at a compression port that is coupled to inputs of the first and second transmission line segments at the first frequency, the compressed resistance range having a range ratio that is less than a range ratio associated with at least one of the first resistance range and the second resistance range, wherein a range ratio of a range comprises a ratio between a highest value in the range and a lowest value in the range.

In accordance with a further aspect of the concepts, systems, circuits, and techniques described herein, an energy recovery system to simulate behavior of a resistive termination for a radio frequency (RF) circuit coupled to the energy recovery system is provided. More specifically, the energy

recovery system comprises: a rectification system having a plurality of tuned rectifier circuits, the plurality of tuned rectifier circuits including at least a first tuned rectifier circuit and a second tuned rectifier circuit; an RF input network to feed the rectification system, the RF input network comprising a resistance compression network that includes: a first transmission line segment having a first electrical length at a first frequency, the first transmission line segment having an output coupled to the first tuned rectifier circuit; a second transmission line segment having a second electrical length at the first frequency, the second electrical length being different from the first electrical length, the second transmission line segment having an output coupled to the second tuned rectifier circuit; and a compression port coupled to inputs of the first and the second transmission line segments; wherein, at the first frequency, an equivalent resistance looking into the compression port varies over a first resistance range as equivalent resistances of the first and second tuned rectifier circuits vary over a second resistance range, wherein a range ratio of the first resistance range is less than a range ratio of the second resistance range, the range ratio comprising a ratio of a largest resistance in a corresponding range to a smallest resistance in the corresponding range; and a dc-dc converter system having an energy recovery input port and a dc output port, the energy recovery input port of the dc-dc converter system being coupled to the output port of at least one tuned rectifier circuit of the rectification system.

BRIEF DESCRIPTION OF THE DRAWINGS

The foregoing features may be more fully understood from the following description of the drawings in which:

FIG. 1 is a block diagram illustrating an exemplary energy recovery system in accordance with an embodiment;

FIGS. 2A-2F are schematic diagrams illustrating energy recovery dc-dc converter systems in accordance with various embodiments;

FIGS. 3A-3F are schematic diagrams illustrating tuned rectifier circuits that use diodes to perform rectification in accordance with various embodiments;

FIGS. 4A-4B are schematic diagrams illustrating tuned rectifier circuits that use transistors to perform rectification in accordance with various embodiments;

FIG. 5 is a schematic diagram illustrating a rectifier circuit having a series tank and a parallel tank coupled to an input thereof in accordance with an embodiment;

FIG. 6A is a schematic diagram illustrating an example resistance compression network (RCN) that may be used to provide power dividing and impedance shaping at the input of an energy recovery system in accordance with an embodiment;

FIG. 6B is a schematic diagram illustrating a higher order RCN that may be used to provide power dividing and impedance shaping at the input of an energy recovery system in accordance with an embodiment;

FIG. 6C is a schematic diagram illustrating an RCN that utilizes transmission-line sections and reactances to provide power dividing and impedance shaping at the input of an energy recovery system in accordance with an embodiment;

FIG. 8D is a schematic diagram illustrating a network that provides un-equal power sharing and impedance shaping at the RF input of an energy recovery system in accordance with an embodiment;

FIG. 6E is a schematic diagram illustrating a network that may be used to provide additional power division using an

isolating power splitter to divide power among multiple resistance-compressed rectifier systems in accordance with an embodiment;

FIGS. 7A and 7B are schematic diagrams illustrating conversion networks that may be used to transfer energy from a floating input voltage port to a common-referenced output port in accordance with embodiments;

FIG. 8A is a schematic diagram illustrating an energy recovery system using an isolator as part of the energy recovery system input network in accordance with an embodiment;

FIG. 8B is a schematic diagram illustrating an energy recovery system using a circulator and providing "multilevel" isolation and energy recovery in accordance with an implementation;

FIG. 9A is a block diagram illustrating an isolator system using energy recovery at a termination port thereof in accordance with an embodiment;

FIG. 9B is a block diagram illustrating a combiner/splitter using energy recovery in accordance with an embodiment;

FIG. 9C is a block diagram illustrating a combiner/splitter using energy recovery that utilizes differential to single-ended conversion in the energy recovery system in accordance with an embodiment;

FIGS. 9D and 9E are block diagrams illustrating example power amplification systems using energy recovery in accordance with various embodiments;

FIG. 10A is a schematic diagram illustrating a transmission-line resistance compression network (TLRCN) providing power dividing and impedance shaping and having an input port and two output ports, with the output ports loaded with a pair of resistive loads;

FIG. 10B is a plot of the normalized input resistance versus the normalized load resistance for a single-level transmission-line resistance compression network, with the normalized load resistance plotted on a log scale;

FIG. 10C is a plot showing the ratio of maximum input resistance to minimum input resistance plotted versus the ratio of maximum load resistance to minimum load resistance for a single-level transmission-line resistance compression network, assuming balanced compression;

FIG. 10D is a schematic diagram illustrating a transmission-line resistance compression network (TLRCN) providing power dividing and impedance shaping and having an input port and two output ports, with the output ports loaded with a pair of resistive loads;

FIG. 10E is a schematic diagram of an exemplary multi-level transmission-line resistance compression network (TLRCN) providing power dividing and impedance shaping and having an input port and four output ports, with the output ports loaded with resistive loads; and

FIG. 10F is a schematic diagram of an exemplary resistance-compressed rectifier system incorporating a multi-level transmission-line resistance compression network (TLRCN) and a set of resonant rectifiers.

DETAILED DESCRIPTION

Systems and techniques are described herein for providing desired operational characteristics of a resistive termination in a radio frequency (RF) system, while also allowing power that would normally be dissipated in a resistive termination to be recovered and converted to a useable form. Likewise, a termination to a radio-frequency power receiver (such as an antenna or coil) that maintains desirable operating characteristics (e.g., providing a constant matched resistive termination) as operating conditions change can capture RF power that would normally be reflected or lost. To recover RF power

and convert it to direct current (dc) signals, the power must be rectified. However, rectification presents many challenges in practice, especially at microwave frequencies (e.g., frequencies above 300 MHz).

First, while one may desire a constant resistive input impedance (e.g., 50 Ohms) to realize a desired circuit function, rectifiers at microwave frequencies typically present effective input impedances that are difficult to make resistive and which vary with RF power level and dc output voltage. In systems having a high peak-to-average power ratio, the problem is particularly challenging. Second, harmonics in the RF input or associated with the rectifier system itself can affect rectifier behavior, and harmonic voltages or currents generated at the energy recovery system input by rectifier operation can be problematic to overall system operation. Third, devices capable of rectifier operation at microwave frequencies are often small (and hence cannot individually handle needed power levels), and rectifier circuits employing them are constrained to operate at low alternating current (ac) input voltages and at dc output voltages that may not be useful for utilizing recovered energy. Moreover, at microwave frequencies, the parasitics associated with rectifier devices (such as, for example, device capacitance and package inductance) can have substantial influence on circuit operation, and make it difficult to provide the desired RF input characteristics. Lastly, the RF input port where the resistor is being replaced is often floating with respect to system ground, while the recovered energy must often be provided at an output port that is referenced to system ground. In various aspects described herein, techniques and circuits are provided that make energy recovery at microwave frequencies practical and effective.

FIG. 1 is a block diagram illustrating an exemplary energy recovery system 10 in accordance with an embodiment. As illustrated, the energy recovery system 10 includes: an energy recovery dc-dc converter system 12, a plurality of tuned rectifier circuits 14, and an RF input network 16 providing functions such as input impedance shaping, filtering, RF power distribution to the plurality of rectifier circuits, and/or level shifting. As will be described in greater detail, in some alternative embodiments, multiple sets of rectifiers and RF input networks may be coupled to the same energy recovery dc-dc converter. In some other embodiments, an individual energy recovery dc-dc converter system may be provided for each rectifier. Other architectures are also possible.

As mentioned above, one challenge to realizing a practical RF energy recovery system is the fact that effective rectifier input impedance (i.e., the complex ratio of the fundamental component of RF voltage to fundamental RF current at the rectifier input port) depends upon the RF input power level and the rectifier output voltage. Moreover, the output voltage that a practical rectifier device or circuit can operate into is often not at a useful level for utilizing recovered energy. The energy recovery dc-dc converter system 12 is provided to address this challenge.

FIG. 2A is a schematic diagram illustrating an exemplary energy recovery dc-dc converter system 20 in accordance with an embodiment. As illustrated, the energy recovery dc-dc converter system 20 includes a single dc-dc converter 22. In some implementations (e.g., designs operated to include burst-mode operation), input and output capacitances C_{RO} 24 and C_{OUT} 26 may be provided at the input and output of converter 22 to limit voltage ripple under bursting at frequencies below the converter switching frequency. The energy recovery dc-dc converter system 20 of FIG. 2A may be used in an energy recovery system that uses, for example, a single dc-dc converter (e.g., the energy recovery system of FIG. 1). As illustrated, converter system 20 includes an input port 28

to be coupled to the outputs of the plurality of rectifiers and an output port 30 to be coupled to a load network to which recovered energy is to be delivered. In order to provide desired impedance characteristics at the RF energy recovery system input, the energy recovery dc-dc converter system 20 may be controlled to regulate the voltage at input port 28 while absorbing the power delivered from the rectifiers and delivering the absorbed power to output port 30. This can be achieved using, for example, a dc-dc converter such as a buck converter, a boost converter, a flyback converter, a buck-boost converter, or other topology, with control designed to regulate the input voltage of the dc-dc converter. Output power from the converter can be provided to a regulated or unregulated output.

The energy recovery system may often be required to operate at high peak-to-average RF power ratios. Consequently, the instantaneous power delivered to the energy recovery dc-dc converter input port 28 may vary over a wide range. Therefore, in some embodiments, converter 22 may be optimized for operation over a wide range of power levels, including the use of burst mode, cycle skipping, gate-width switching, phase shedding, and related techniques to maintain high efficiency over a wide power range.

In one implementation, the dc-dc converter 22 of FIG. 2A may be rated for the peak RF power to be recovered, thereby enabling continuous operation at peak RF power conditions. In some applications, however, it is known that such peak power conditions only occur for a limited duration. In these applications, the energy recovery converter input capacitor 24 (or other energy storage element) may be made sufficiently large such that the converter only needs to process a fraction of the peak power rating of the recovery system (but at least the average power rating), while still enabling the voltage at the rectifier output (and the energy recovery converter input 28) to be regulated to within a desired voltage range.

In many applications, it may be desirable to regulate the energy recovery converter input 28 to a nearly fixed voltage independent of rectifier input power, to provide desired operating characteristics (and effective input impedance values) of the rectifiers and, in turn, desired input impedance characteristics of the energy recovery system. In one exemplary embodiment, this is achieved by comparing the energy recovery power converter input voltage to a reference voltage to generate an error signal, and controlling the converter input current, switch current, burst rate, switching frequency, duty ratio or other control variable as a function of the error signal. That is, in this approach, the converter input voltage is regulated to a value at or near the reference voltage by feedback control of the converter. FIG. 2D is a block diagram illustrating example circuitry for performing this voltage regulation in accordance with an exemplary embodiment.

Alternatively, the energy recovery converter input voltage V_{RO} may be regulated to a voltage that is a function of the current or power delivered to or from the rectifiers. This can be used to extend the operating power range over which the energy recovery system has desirable effective input impedance characteristics (e.g., 50 Ohms, etc.). To understand this, it should be recognized that the effective input resistance of a rectifier is a function of both the power level at which the rectifier is operating and of the rectifier output voltage. For example, as is known in the art, some rectifiers ideally provide an input resistance at the fundamental operating frequency of the form $R_{eff} = k(V_{RO})^2/P$, where R_{eff} is the effective resistance at the rectifier input, V_{RO} is the rectifier dc output voltage, P is the rectifier output power, and k is a constant that depends on the rectifier topology. For an ideal full-bridge diode rectifier topology, for example, $k = 8/\pi^2$. For an ideal voltage-doubler

rectifier topology, $k=2/\pi^2$ and so on. By adjusting the energy recovery converter input voltage (rectifier output voltage) to be smaller for low power (or rectifier current) levels, the effective resistance provided by the rectifier can be more approximately constant (vary over a smaller range) than if a constant voltage V_{RO} is used. This can be achieved by adjusting the above-mentioned reference voltage as a function of measured, estimated, or expected power, current or another related variable. It should be noted that to achieve this dynamic reference alternative, it is desirable to size the energy recovery converter input capacitance C_{RO} (in conjunction with any rectifier output capacitance) large enough such that the rectifier output voltage ripple at the RF frequency and harmonics is small, but small enough that the rectifier output voltage can adjust on a time scale associated with the power variations to be compensated. FIG. 2E is a block diagram illustrating example circuitry for performing voltage regulation with a dynamic reference in accordance with an exemplary embodiment.

FIG. 2B is a schematic diagram illustrating an energy recovery dc-dc converter system **40** in accordance with another embodiment. In this embodiment, the energy recovery converter **42** is provided with a third port **44** from which energy may be drawn and/or delivered. With a third port, the energy recovery converter **42** can be configured to regulate the voltage at both its input port (V_{RO}) **46** and its output port (V_{OUT}) **48**. For example, in one approach, the converter **42** can be configured as a two-input dc-dc converter with a single output. In another approach, the converter **42** can be configured to transfer power in any direction among the ports **44**, **46**, **48**. Power needed to regulate the output port voltage that is not sourced from the input port (and rectifiers) can instead be sourced from the third port **44**. Typically, the third port **44** will provide an average source of power, but in some cases it may be constructed as a large energy buffer only, such that long-term average power is always sourced from the input port and only temporarily stored at the third port **44**. As described above, V_{RO} may be regulated to a fixed voltage or to a variable voltage.

FIG. 2C is a schematic diagram illustrating another exemplary energy recovery dc-dc converter system **50** in accordance with an embodiment. In this embodiment, a first converter **52** supplied from a third port **54** (V_{P3}) regulates the voltage (V_{RO}) at the energy recovery converter system input port **56** (i.e., the rectifier output), while a second converter **58** is supplied from this voltage and regulates voltage (V_{OUT}) at an output port **60**. While the first and second converters **52**, **58** may both be provided as switched-mode converters, in some applications the second converter **58** (regulating V_{OUT}) may be realized as a linear regulator to reduce noise at the output port **60**. In some embodiments, additional converters powered from V_{RO} may be utilized to regulate additional outputs. The additional converters can each be powered directly from V_{RO} or they can be cascaded so that the output of one converter powers the input of another, and so on.

FIG. 2F is a schematic diagram illustrating an energy recovery dc-dc converter circuit **100** that may be used within an energy recovery system in accordance with an embodiment. The dc-dc converter circuit **100** uses an off the shelf, integrated, high voltage boost converter IC **102** (e.g., Texas Instruments TPS61170) that is coupled to control circuitry for supporting operation in an energy recovery system. The high voltage boost converter IC **102** has a feedback port that was designed for use in controlling the output voltage of the converter. As shown in FIG. 2F, the energy recovery dc-dc converter circuit **100** includes logic coupled to the feedback port of the boost converter IC **102** that causes the chip to

regulate the input voltage of the converter rather than the output voltage. It should be appreciated that the energy recovery dc-dc converter circuit **100** of FIG. 2F is an example of one possible converter design that may be used within an energy recovery system in an embodiment. Other converter designs may be used in other implementations.

As described previously, one of the functions of the dc-dc converter system **12** of FIG. 1 is to convert the dc output signal of the rectifier(s) to a useable dc output voltage. As used herein, the phrase “useable dc output voltage” and similar terms refer to voltages that are useable to perform some desired function. In various implementations, the dc output voltage of the converter may be used to, for example, power other circuitry or devices, charge a battery, provide power to a power amplifier and/or to control circuitry, or perform some other function. In each case, the dc-dc converter system may be used to generate a dc output voltage that is useable to support the corresponding function.

As described above, one component in the energy recovery system **10** of FIG. 1 is the rectifier circuit that converts RF to dc. As shown in FIG. 1, in some implementations, a plurality of rectifiers **14** may be used to provide the overall conversion from RF to dc. A plurality of rectifiers may be used for multiple reasons. First, devices capable of efficient rectification at microwave frequencies are often small and, therefore, may not be able to handle the needed power levels individually. Second, it is often easier to take advantage of circuit parasitics (or mitigate parasitics) for smaller rectifier devices than for larger ones. In addition, as will be described in greater detail, use of a plurality of rectifiers permits a rectifier system to be constructed that provides lower effective input impedance variation than is provided by a single rectifier.

In the discussion that follows, the design of individual tuned rectifier circuits will be described. Techniques for integrating multiple rectifier circuits into a rectification system will be described later. It is desired to have a rectifier that provides approximately resistive effective input impedance (i.e., having the fundamental component of RF voltage substantially in phase with fundamental RF current at the rectifier input port) with as little variation in effective impedance (ratio of fundamental voltage to current) as possible across operating conditions. As is known in the art, the effective impedance presented by a rectifier is a function of power and rectifier output voltage. Moreover, with conventional rectifiers (e.g., implemented with diodes), even the small parasitics associated with device capacitance, package capacitance and package inductance can cause substantial deviations from resistive input impedance. To address these challenges, in at least one embodiment, rectifiers incorporating tuned networks are used, where the tuned networks incorporate device and/or package parasitics to achieve the desired operating characteristics. Such tuned or resonant rectifiers can provide nearly resistive input resistance characteristics across a wide power range (e.g., impedance phase magnitude of less than 20 degrees over more than a 5:1 power range, etc.).

FIG. 3A is a schematic diagram of an exemplary tuned rectifier circuit **110** in accordance with an embodiment. The tuned rectifier circuit **110** is shown using a Schottky diode **112**, but other device types may also be used (e.g., lateral field-effect rectifiers, etc.). Capacitor **114** represents a capacitance (C_R) including one or more of diode capacitance, diode package capacitance, and added circuit capacitance, and forms part of the tuning network. Capacitor **116** represents the rectifier output capacitance (C_{ROUT}). It provides a low impedance to RF, yielding approximately constant voltage at the rectifier output. Inductor **118** represents the rectifier

inductance (L_R) which also forms part of the tuned network. The value of the rectifier inductance (L_R) may include diode package inductance.

In one approach, inductor **118** may be tuned near resonance with capacitor **114** (e.g., L_R on the order of $1/(4\pi^2f^2C_R)$). For a given value of C_R , the exact value of L_R can be selected using simulation software, such as SPICE. The network is loaded with a specified fixed output voltage V_{RO} and driven with a sinusoidal input current I_{RF} (at the design frequency), with L_R selected such that the fundamental of V_{RF} is nearly in phase with I_{RF} for a range of current amplitudes. One may adjust the value of C_R (by changing discrete capacitance, diode size, etc.) and subsequently retune L_R in order to achieve resistive operation of the rectifier at a desired range of power levels (and to best utilize the rectifier device capabilities). In some cases, to achieve the best resistive input impedance across power, a small reactance may be added (inductive or capacitive, not shown) in series with the positive RF input terminal of the rectifier **110**. This optional reactance, which would typically be much smaller than the reactance of L_R or C_R , can be used to offset any residual reactance from the tuning process.

FIG. 3B is a schematic diagram illustrating an exemplary tuned rectifier circuit **120** in accordance with an embodiment. In tuned rectifier **120**, C_{ROUT} is again the rectifier output capacitance, which provides a low impedance at the operating frequency. C_R is the resonant capacitance and incorporates the diode capacitance, and L_R is the resonant inductance and may incorporate diode package inductance. In general, there needs to be a dc current path at the rectifier input in the embodiment of FIG. 3B, this path is provided by an explicit inductor (i.e., optional choke inductance **122** (L_{DC})) across the input terminals. In other embodiments, elements external to the rectifier **120** may be used to provide the dc current path. Tuning of this rectifier **120** may be carried out in a similar manner to the rectifier of FIG. 3A. However, instead of driving the rectifier circuit **120** with a sinusoidal current during tuning, the circuit may be driven with a sinusoidal voltage while observing the fundamental of the rectifier input current.

In some implementations, rectifier circuits may be provided that also include tuning for higher-order harmonics. FIG. 3C is a schematic diagram illustrating such a tuned rectifier circuit **130** in accordance with an embodiment. As illustrated, the rectifier circuit **130** of FIG. 3C includes a series tank **132** having an inductance $L2$ and a capacitance $C2$ tuned at the second harmonic to reduce device voltage stress. Rectifier circuits may also be provided that use transmission-line sections to perform some or all of the tuning function. For example, FIG. 3D is a schematic diagram illustrating a tuned rectifier circuit **140** using transmission line segments in accordance with an embodiment. As illustrated, the rectifier circuit **140** of FIG. 3D includes a quarter-wavelength line segment **142** to provide reduced voltage stress. In some implementations, the line length of this segment may be adjusted slightly longer or shorter than a quarter wavelength to compensate for rectifier device capacitance and/or inductance. FIG. 3E is a schematic diagram illustrating a class E/F rectifier **150** having a differential input port **152** in accordance with an embodiment. This rectifier circuit **150** can be driven differentially, or its input can be converted to a single-ended port using a splitter/combiner. It will be appreciated that other types of tuned rectifier circuit may be used, including those with other harmonic tunings, and those incorporating multiple diodes. In general, the tuning of a rectifier may involve selecting the inductances and capacitances such that the ac

current (or voltage) at the rectifier input is substantially in-phase with the ac voltage (or current) at the rectifier input for the frequency of interest.

FIG. 3F is a schematic diagram illustrating a resistance compressed rectifier system **160** having a pair of tuned rectifiers preceded by a resistance compression network having a pair of 50 ohm transmission line segments in accordance with an embodiment. The resistance compression network acts as an RF input network for the tuned rectifiers (although additional RF input network circuitry may be added in some implementations). The resistance compressed rectifier system **160** of FIG. 3F is operative at 2.14 GHz with a dc output voltage of 7 V and an RF input impedance near 50 Ohms.

While the tuned rectifier circuits of FIGS. 3A-3F are shown with Schottky diodes, it should be appreciated that other diode types or device types may be employed in other implementations to perform the rectification function. In some implementations, for example, transistors may be used to provide rectification (e.g., MOSFETs, JFETs, HEMTs, HBTs, etc.). FIG. 4A is a schematic diagram illustrating a tuned rectifier circuit **170** that uses a transistor **172** to perform rectification in accordance with an embodiment. As illustrated in FIG. 4A, to perform rectification, the gate of the transistor **172** may be biased to an appropriate dc potential (e.g., V_B). Alternatively, the gate terminal may be actively driven at RF to provide synchronous rectification (e.g., V_B in FIG. 4A may include a dc bias plus an RF signal with appropriate phase relative to V_{RF}). FIG. 4B is a schematic diagram illustrating a tuned rectifier circuit **180** that performs synchronous rectification using transistors **182**, **184** that are "cross-driven" from the RF input signal itself. In general, synchronous rectification involves turning a transistor on and off with timing such that it carries an average dc current, thus providing conversion from an ac input to a dc output. In one approach, each transistor gate may be driven such that the transistor conducts current of substantially one polarity, and is turned off otherwise. That is, the transistor may be driven to conduct in a manner similar to a diode, but having a lower device drop than a diode.

Another component in the energy recovery system of FIG. 1 is the RF input network **16** that addresses challenges associated with capturing RF energy. These challenges include the generation of undesired frequencies by the rectifiers, the need to operate with small individual rectifier devices, rectifier input impedance variations, operation at high peak-to-average power ratios, and energy capture at circuit ports that are not referenced to a common potential. As will be described below in greater detail, each of these challenges may be addressed by specific elements of the RF input network.

A byproduct of the rectification process is often the presence of dc, switching harmonics, and other undesired frequency components at the rectifier inputs. These undesired frequency components can cause deleterious effects in the energy recovery system. For example, the unwanted frequency content can pollute the system that the energy recovery system is connected to, can cause undesired interactions among the multiple rectifier circuits, as well as other negative effects. To suppress this content, filtering may be provided at the rectifier inputs and possibly at points closer to the energy recovery system input. In some embodiments, these filters may include tuned series and/or parallel tanks in series with the rectifier inputs (and/or interconnections) or in parallel with the rectifier inputs. For example, FIG. 5 is a schematic diagram illustrating a rectifier circuit **190** having a series tank **192** and a parallel tank **194** coupled to an input thereof, where the series tank **192** is tuned to the input frequency to pass

through the desired fundamental and the parallel tank **194** is tuned to the input frequency to suppress unwanted content. Other bandpass and/or bandstop filtering (e.g., tuned to harmonics) may also be employed, as well as low-pass and high-pass filters to suppress undesired content. These filters may be implemented with discrete or integrated passive components, with transmission-line sections, or as a combination of these elements.

As described previously, better rectifier performance can sometimes be achieved at RF frequencies using rectifier devices that are small in power rating and physical size, making it advantageous to construct an energy recovery system from multiple rectifiers of reduced power rating. Moreover, utilizing a plurality of rectifiers, one can construct a rectifier system providing lower effective input impedance variation than is provided by a single rectifier, as described in detail below. To implement a multi-rectifier system, in at least one embodiment, the RF input network may include a power dividing and impedance shaping network that splits power among the various rectifiers and provides an input impedance that varies over a smaller range (e.g., a ratio of input resistances or input impedance magnitudes) than the individual rectifiers. Desirable attributes of such a power dividing network include relatively even power splitting among the individual rectifiers and lossless or very low loss operation.

In some embodiments, a resistance compression network (RCN) may be used to provide the power dividing and impedance shaping network of the RF input network. FIG. 6A is a schematic diagram illustrating an exemplary resistance compression network **200** that may be used in an embodiment. This network is ideally lossless and splits input power among two rectifiers **202**, **204** approximately equally, while providing a resistance at its input port **206** that varies over a smaller range than the individual rectifiers **202**, **204**. This thus forms a “resistance-compressed rectifier system.” The compression branch impedance magnitude X is selected based on the input impedance range provided by the rectifiers **202**, **204**. In constructing RCNs of the type in FIG. 6A for operation at microwave frequencies, care should be taken to minimize or compensate (e.g., “resonate out”) shunt parasitics at the intermediate nodes (e.g., between the inductors and capacitors).

The resistance compression network **200** of FIG. 6A, constructed with discrete components, has the benefits of being compact and providing good operational bandwidth. Higher-order resistance compression networks (or “multilevel” compression networks) can also be used, such as the “second order” (or two-level) RCN **210** of FIG. 6B that can split power among four rectifier circuits **212**, **214**, **216**, **218**. An RCN of order M , or an M -level RCN, can split power among $N=2^M$ rectifier circuits. Other RCN variants may alternatively be used, including RCNs that are achieved by topological duality or star-delta transformations of the network elements, RCNs that use different component types to realize the needed reactances, and RCNs that use circuit board or microstrip elements.

Power dividing and resistance compression can also be achieved with circuits incorporating transmission-line sections (e.g., section of microstrip, etc.). FIG. 6C is a schematic diagram illustrating a resistance compression network **230** that uses quarter wavelength transmission line sections **236**, **238** and reactances **240**, **242** to perform resistance compression for first and second rectifiers **232**, **234**. In resistance compression network **230**, the reactive components **240**, **242** may be realized as discrete components, components implemented in the circuit board, or as transmission-line stubs. In this embodiment, in addition to working with the shunt ele-

ments to realize resistance compression, the characteristic impedance of the quarter-wave lines **236**, **238** can be selected to provide a desired degree of impedance transformation. FIG. 3F described previously illustrates the details of an example implementation of a resistance-compressed rectifier system **160** that uses the resistance compression network architecture illustrated in FIG. 6C.

The power dividing and impedance shaping network of the RF input network may also be implemented using other network types and topologies. For example, FIG. 6D is a schematic diagram illustrating a network **250** that serves to provide a degree of impedance shaping such that the impedance at the RF input **252** varies over a smaller range (e.g., ratio of input resistances or input impedance magnitudes) than the individual rectifiers **254**, **256**, though it does not cause power to be shared equally among the rectifiers **254**, **256** across operating conditions. The network **250** can be extended for use with additional rectifiers by paralleling additional rectifier-loaded quarter-wave-line branches having different characteristic impedances and appropriately designed rectifiers.

Additional power dividing can be obtained using networks that are not ideally lossless and/or which do not provide reduction in impedance range. For example, power may be split further using an isolating power splitter to divide up power to multiple resistance-compressed rectifier systems. FIG. 6E illustrates a network **260** that uses a two way splitter **262** (e.g., a Wilkinson splitter, a Gysel splitter, a hybrid splitter, etc.) to split power between first and second resistance-compressed rectifier systems **264**, **266**. Many-way splitters can be used when there are more than two resistance-compressed rectifier systems. While providing power dividing in this fashion does not provide additional reduction in impedance ranges, it can be made highly efficient, and the isolation helps soften the variations in input impedance. Moreover, it enables systems of different energy recovery power capacities to be simply constructed.

In some embodiments, the RF input port of an energy recovery system is referenced to a common potential (e.g., ground, etc.). However, in some cases, the input port may be “differential” or floating (or “flying”) with respect to system ground, while the recovered energy must be provided at an output port that is referenced to system ground. For example, the isolation port of a Wilkinson combiner is not ground referenced, but represents a “differential” input. One technique to recover energy at a floating or “flying” input port involves the use of an RF transformer or balun to transfer energy from the flying input voltage to a common-referenced port. FIG. 7A is a schematic diagram illustrating an example conversion network **270** for doing this in accordance with an embodiment. If such an approach is used, the energy may be recovered at the common-referenced port as described above. In the embodiment of FIG. 7A, energy at port AB **272** is delivered to output port CG **274** with $V_{CG}=(N_2/N_1)\cdot V_{BA}$. If the effective turns ratio is not unity, network **270** also provides an impedance transformation such that $Z_{diff}=(N_1/N_2)^2\cdot Z_{RF}$. Depending on dc levels, one or both of the ports **272**, **274** may require a series blocking capacitor, and one may also need to tune out transformer parasitics (such as leakage inductances and/or magnetizing inductance) at the RF frequency of interest (e.g., using capacitors).

Another technique to transfer energy from a “flying” input port to a common-referenced port for energy recovery purposes involves the use of transmission-line sections. FIG. 7B is a schematic diagram illustrating an example conversion network **280** that uses transmission line sections **286**, **288**, **290** to transfer energy between ports in accordance with an embodiment. At the design frequency, conversion network

280 transfers energy from a floating port **282** to a common-referenced port **284** according to the relationship $V_{CG} = (Z_1/Z_0) \cdot V_{BA}$. Network **280** can provide both a differential to single-ended conversion and an impedance transformation, such that $Z_{diff} = (Z_0/Z_1)^2 \cdot Z_{RF}$. In some cases, the Z_1 transmission line section can be omitted. For example, in cases where the load provided by the energy recovery system is at or near impedance Z_1 , the transmission section can be omitted. Similarly, in cases where the impedance inversion provided by the quarter-wave section **290** is not a problem, this transmission line section can be omitted. Also, it will be recognized that blocking capacitors may be used in series with one or more of the terminals of the differential conversion network in some implementations. Note that the network can also be implemented with lumped transmission-line approximations, with other immittance converting circuits taking the function of each quarter-wave section, or combinations of lumped and distributed structures serving the same or similar functions.

Other alternative techniques for converting “flying” or differential inputs to common-referenced outputs for energy recovery can be utilized in other embodiments. Combined with the other portions of the energy recovery system, these techniques enable RF energy to be recovered from “flying” ports.

It is recognized that even with filtering, some applications may be sensitive to any reflected power from the energy recovery system (including at the operating frequency, harmonics, or other frequencies). In such cases, an isolator may be used as part of the energy recovery input network to terminate any reflected power generated by the energy recovery system. As shown in FIG. 8A, an isolator **300** may be placed at the input of an energy recovery block **302** so that reflections from the input are directed to termination **304**. It should be appreciated that other isolator locations are also possible.

FIG. 8B is a schematic diagram illustrating an energy recovery system **310** that uses an isolator **312** to provide “multilevel” isolation and energy recovery in accordance with an implementation. As shown, a number of energy recovery blocks **314**, **316** are coupled to ports of isolator **312**. Each energy recovery block **314**, **316** incorporates one or more energy recovery rectifiers and possibly other subsystems, as described above. Multilevel isolation provides the opportunity to capture RF power at different power levels and contents, and may be implemented with a 4 or more port circulator and a terminating resistor, or a cascade of 3-port circulators and a terminating resistor.

The availability of an energy recovery system also enables additional functions and features to be realized. One such function is power monitoring. For example, an additional circuit can be provided that monitors information about the energy recovery system, such as the input and/or output power of the system. In some implementations, the system output power is monitored using the sensing and/or control signals of the energy recovery dc-dc converter. In some other implementations, the output power may be monitored using additional low-frequency sensors or other structures. In at least one embodiment, the input power may be monitored based on the operating point of the rectifier circuits. Alternatively, the input power may be monitored based on the operation of the energy recovery converter (e.g., estimating input power based on the known characteristics of the system and the converter input or output current, voltage, or power or rectifier input or output voltage, current, or power). Additional monitoring circuitry may also be provided in some embodiments. This may include, for example, circuitry for monitoring system temperature, operating status, and/or other critical operating parameters.

Many RF circuits incorporate power resistors that dissipate energy during circuit operation. Such circuits include RF hybrids, power combiners and dividers, isolators, RF power amplifier systems, duplexers, filters and termination networks, among other devices. Each of these circuit types can benefit by incorporating the energy recovery techniques described herein. Likewise, many RF circuits seek to absorb energy from an antenna, transformer secondary, coil, or other means of receiving RF energy, including in rectenna systems, wireless power transfer systems, inductive power coupling systems, radio-frequency power converter systems including RF dc-dc converters, and microwave power transmission systems. It is desirable to be able to capture RF energy in these systems and convert it to useable form, while minimizing reflected or dissipated RF power. Each of these circuit types can likewise benefit by incorporating the energy recovery techniques described herein.

One type of circuit that can benefit from the described techniques is an isolator. FIG. 9A is a block diagram illustrating the use of an energy recovery system **322** (e.g., the energy recovery system of FIG. 1, etc.) as a termination for an isolator **320**. As illustrated, the isolator **320** includes a circulator **324** having three ports, with the energy recovery system **322** coupled to one of the three ports (i.e., instead of a conventional resistive termination). A first port of the circulator serves as the input port of the isolator **320** and a second port serves as the output port. RF power delivered to the isolator input port is transferred to the isolator output port. Any power entering the isolator output port (e.g., power reflected back into the isolator output port from a mismatched load and/or any other power) is transferred to the energy recovery system **322** at the third port of the circulator **324**. In this manner, the energy may be at least partially recovered for other uses instead of being lost to dissipation as would occur with a conventional resistive termination.

Another application that can benefit from energy recovery is power combining and/or splitting. FIG. 9B is a block diagram illustrating the use of an energy recovery system **330** to provide energy recovery for a combiner/splitter **332** in accordance with an embodiment. The combiner/splitter **332** may include, for example, a rat-race hybrid, a branchline hybrid, a 90 or 180 degree hybrid, or others.

In the illustrated embodiment, the combiner/splitter **332** includes four ports: port 1, port 2, a sum port, and a difference (delta) port. The energy recovery system **330** may be coupled to either the sum port or the difference port. The energy recovery system **330** may provide, for example, a proper termination for the corresponding port (e.g., the difference port in FIG. 9B) while the other port (e.g., the sum port in FIG. 9B) is used as a “combined” port. In this manner, combining and/or splitting may be achieved between the combined port and ports 1 and 2, while energy is recovered for isolation at the energy recovery output port.

In some systems, three (or more) way combining/splitting may be used. FIG. 9C is a block diagram illustrating an implementation that utilizes differential to single-ended conversion in an energy recovery system. The combiner/splitter **348** is implemented as a 3-way Wilkinson combiner/splitter with the ports for isolation (with energy recovery) connected in delta, where each differential input port has an apparent input resistance of approximately $3Z_0$. This system uses three energy recovery rectifier systems **340**, **342**, **344**, each including differential-to-single-ended conversion. The system may also include an RF input network comprising impedance shaping, filtering, distribution, and a plurality of rectifiers, along with a single energy recovery dc-dc converter system **350** to provide recovered energy at the output. In an alterna-

tive approach, this system can be reconfigured such that there is a separate energy recovery dc-dc converter for each of the energy recovery systems. This technique may be used for splitting or combining any number of signals.

Another application that can benefit from the energy recovery techniques described herein is power amplification. More specifically, systems where power from multiple power amplifiers is combined to create a single higher power signal. FIG. 9D is a block diagram illustrating an example power amplification system 400 using energy recovery in accordance with an embodiment. As shown, output power from two power amplifiers 402, 404 is combined using an isolating combiner 406 with energy recovery (e.g., as illustrated in FIG. 9B). Depending on the relative magnitude and phase of the outputs of the two power amplifiers 402, 404, power will be delivered to one or both of first and second output ports of the combiner 406. The first output port is illustrated as the sum port and the second output port is illustrated as the difference port in FIG. 9D. An energy recovery system 408 may be connected to the second output port. This provides the opportunity to load the power amplifiers 402, 404 in an isolating fashion, and at the same time control power (and signal amplitude and phase) delivered to the output port by adjusting the magnitudes and phases of the outputs of the individual power amplifiers 402, 404. Power not delivered to the output port is recovered through the energy recovery system 408 (minus any losses). The magnitudes and phases of the outputs of the individual PAs 402, 404 may be controlled by, for example, any one or more of: (1) individually adjusting one or more of the pulse widths, timing, drive amplitudes, and phases of the power amplifier input signals (e.g., including amplitude modulation, phase-shift or outphasing modulation, PWM modulation, and on/off modulation), (2) individually adjusting the power supply bias voltages of the power amplifiers (e.g., via discrete or continuous drain modulation), (3) load modulation of the individual power amplifiers (e.g., by implementing each power amplifier as a Doherty amplifier or an outphasing amplifier with lossless combining), and/or other techniques. It should be recognized that such a system can also be realized with a larger number of power amplifiers, such as by using the combining and energy recovery system illustrated in FIG. 9C. Such a system enables high efficiency linear control of output power by adjusting the relative operation of the individual power amplifiers.

A power amplifier system with multiple power amplifiers can also be implemented as a balanced power amplifier system that realizes improved efficiency under load mismatch (e.g., from a non-ideal load impedance) at its output port. FIG. 9E is a block diagram illustrating an exemplary system 420 of this type. In system 420, reflected power from an output port of a balanced amplifier 422 is captured by an energy recovery system 424. The recovered energy is provided at a dc output port 426 and may be used to supply part of the power to the power amplifiers 428, 430 of balanced amplifier 422, for powering computation or control circuitry, powering pre-amplifiers, and/or for other uses. The system 420 of FIG. 9E includes a first 90-degree hybrid 440 to provide appropriate phases at the two power amplifier inputs, and a second 90-degree hybrid 442 to combine power from the two power amplifiers 428, 430 for delivery to an RF output port. The energy recovery system 424 is connected to the isolation port of the second hybrid 442. Reflected power entering the output port (e.g., owing to load mismatch) can be substantially captured by the energy recovery system 424, thus providing improved operation under load mismatch.

Resistance compression networks (RCNs) absorb energy from a source and deliver it (ideally losslessly) to a plurality

of loads (e.g., such a set of rectifiers), providing an input resistance that varies over a narrow range as the resistance of the loads vary together over a wide range. Resistance compression networks can also serve to reduce the phase of the input impedance as compared to the phase of the load impedances (phase compression). Ideally, the RCN splits input power substantially equally among the loads. Conventional resistance compression networks use reactances to accomplish this, and may additionally include transmission-line sections, as illustrated in FIGS. 3F and 6C. The reactances themselves may be implemented as transmission-line sections or stubs or otherwise realized in printed-circuit form.

In some embodiments, resistance compression networks may be implemented using transmission-line sections having asymmetric lengths, wherein the transmission-line sections are provided as two-port structures interconnecting among the source and loads. Such Transmission-Line Resistance Compression Network (TLRCN) implementations may provide several benefits. For example, they can (a) have low loss, (b) enable repeatable, low-cost implementation using printed circuit techniques, (c) provide filtering, and (d) with correct length selections, they can provide resistance compression at one or more harmonic frequencies. Moreover, at UHF frequencies and above, the discrete reactances often used in conventional RCN designs represent an increasing challenge. That is, the transmission-line effects associated with their physical size can substantially influence system behavior, and their numerical values can become extremely small, making them difficult to implement accurately and making the system susceptible to parasitic effects. TLRCN implementations, on the other hand, avoid these issues by directly realizing the RCN as a transmission-line structure interconnecting the source and loads.

A description will now be made of the theory and operating characteristics of Transmission-Line Resistance Compression Networks. With a TLRCN network, substantially balanced splitting of power to multiple loads and smaller variation in driving point resistance as compared to load resistance variation may be achieved using only transmission-line sections used as two-port devices to connect among the sources and loads. FIG. 10A shows a basic TLRCN structure, having a single input port (or compression port) with voltage v_{IN} and two output ports with voltages v_{O1} and v_{O2} , with the output ports loaded with identical resistive loads R_L . In each transmission-line section, or branch, in FIG. 10A the second terminal at each port of each transmission-line section may be treated as connected to a common potential at that end of the transmission-line section, as naturally occurs in a microstrip or other printed-circuit implementation, and is thus not shown explicitly. The first transmission-line branch 500 coupled to the input port has characteristic impedance Z_0 and a length l_1 corresponding to an electrical angular delay θ_1 at an operating frequency of interest. The second transmission-line branch 502 coupled to the input port likewise has characteristic impedance Z_0 and a different length l_2 corresponding to an electrical angular delay θ_2 . (Implementation of systems in which the two branches have different characteristic impedances and which operate best with different loading impedances is also possible.) We can express the lengths of the two branches as a base length plus and minus a delta length (or a base angle +/- a delta angle) as follows:

$$\begin{aligned} l_1 &= l_{Base} + \Delta l \\ l_2 &= l_{Base} - \Delta l \end{aligned} \quad (1)$$

$$\begin{aligned} \theta_1 &= \theta_{Base} + \Delta \theta \\ \theta_2 &= \theta_{Base} - \Delta \theta \end{aligned} \quad (2)$$

We obtain desired operating characteristics at a frequency of interest by proper selection of Z_0 , θ_{Base} , and $\Delta\theta$.

While there are multiple possibilities for base lengths, we first consider a base length l_{Base} of $\lambda/4$ (a quarter wavelength at a frequency of interest), corresponding to $\theta_{Base}=\pi/2$ radians. (Any base length with an additional multiple of $\lambda/2$ in length will provide similar results.) Considering the first and second branches **500**, **502** in FIG. **10A** individually, we find branch input admittances at the frequency of interest:

$$Y_{in,1} = \frac{1}{Z_{in,1}} = \frac{1}{Z_0} \cdot \frac{Z_0 - jR_L \cot(\Delta\theta)}{R_L - jZ_0 \cot(\Delta\theta)} \quad (3)$$

$$Y_{in,2} = \frac{1}{Z_{in,2}} = \frac{1}{Z_0} \cdot \frac{Z_0 + jR_L \cot(\Delta\theta)}{R_L + jZ_0 \cot(\Delta\theta)}$$

Since these admittances are complex conjugates, the network will divide power entering the input port equally to both loads (for identical load resistances). The impedance seen at the input port at the frequency of interest is resistive in this case, and can be shown to be:

$$Z_{in} = R_{in} = \frac{|\cot(\Delta\theta)|}{2[1 + \cot^2(\Delta\theta)]} \cdot \left[\left\{ \frac{R_L}{|\cot(\Delta\theta)|} \right\} + \frac{Z_0^2}{\left\{ \frac{R_L}{|\cot(\Delta\theta)|} \right\}} \right] \quad (4)$$

Such a characteristic clearly realizes resistance compression: the input impedance is resistive and varies only over a small range as the load resistances vary together over a wide range. In fact, this input resistance characteristic bears close relation to the input resistance of a type of resistance compression network that uses reactances in series with the load networks (e.g., see FIG. **6A**). With a design selection of $\Delta\theta=\pi/4$ radians ($\Delta l=\lambda/8$), the circuit provides identical characteristics (with the transmission-line characteristic impedance Z_0 taking the place of reactance X in the expression for the input resistance).

In general, a resistance range looking into a resistance compression network described herein will be less than the resistance range associated with the corresponding loads. More specifically, a “range ratio” looking into the resistance compression network will be less than range ratios associated with the loads, where the range ratio of a resistance range is defined as the ratio of a largest resistance value in the range to a smallest resistance value in the range.

Using the above-described network with a base angle of $\theta_{Base}=\pi/2$, “balanced” compression can be achieved for a range of load resistances having a geometric mean of $R_{L,center}$:

$$R_{L,center} = Z_0 \cdot |\cot(\Delta\theta)| \quad (5)$$

At this load resistance value ($R_{L,center}$), the input resistance takes on a minimum value of $R_{in,min}$, with larger input resistance for other load resistances. The value of $R_{in,min}$ may be calculated as follows:

$$R_{in,min} = Z_0 \cdot \frac{|\cot(\Delta\theta)|}{[1 + \cot^2(\Delta\theta)]} \quad (6)$$

FIG. **10B** shows a plot of the input resistance (normalized to $R_{in,min}$) as a function of the load resistance (normalized to $R_{L,center}$), with the normalized load resistance on a log scale. FIG. **10C** shows the detail of the ratio of the maximum to

minimum input resistance plotted as a function of the maximum to minimum load resistance, assuming balanced compression (i.e., with $R_{L,center}$ selected as the geometric mean of $R_{L,max}$ and $R_{L,min}$). For this case, we find:

$$\frac{R_{in,max}}{R_{in,min}} = \frac{1}{2} \left[\sqrt{\frac{R_{L,max}}{R_{L,min}}} + \sqrt{\frac{R_{L,min}}{R_{L,max}}} \right] \quad (7)$$

Which, for large values of $R_{L,max}/R_{L,min}$ approaches:

$$\frac{R_{in,max}}{R_{in,min}} \approx \frac{1}{2} \sqrt{\frac{R_{L,max}}{R_{L,min}}} \quad (8)$$

The high degree of resistance compression provided by this system can be seen in these expressions and in FIG. **10C**, with a 10:1 ratio of load resistance compressed to a 1.74:1 ratio in input resistance and a 100:1 ratio in load resistance compressed to only a 5.05:1 ratio in input resistance. As with conventional resistance compression networks, one can also use the TLRCN to provide phase compression in which for identical non-resistive loads, the input impedance is more nearly resistive than the load impedances themselves.

It should be noted that other base lengths besides $l_{Base}=\lambda/4$ ($\theta_{Base}=\pi/2$ radians) can be used. For example, a base length of $l_{Base}=\lambda/2$ ($\theta_{Base}=\pi$ radians) likewise results in equal power transfer to the two loads and a compressed resistive input impedance. The characteristics associated with this base length will be the same as that in Equations (3)–(6), except with $\cot(\Delta\theta)$ replaced with $-\tan(\Delta\theta)$ in each expression. Likewise, operation will be the same with any additional multiple of $\lambda/2$ added to the base length. Because of this, with appropriate selections of base length at a desired fundamental frequency, the system can be designed to also provide resistance compression at one or more harmonic frequencies (and at subharmonic frequencies), provided that the loads have appropriate frequency characteristics.

There are multiple possible design approaches for TLRCN circuits. Considering a base length $l_{Base}=\lambda/4$ ($\theta_{Base}=\pi/2$ radians), one may a priori select a value of $\Delta\theta=\pi/4$ radians ($\Delta l=\lambda/8$), such that $\theta_1=3\pi/4$ and $\theta_2=\pi/4$. For balanced compression, one may then select Z_0 as $R_{L,center}$ (the geometric mean of the maximum and minimum load resistances $R_{L,max}$ and $R_{L,min}$). In this case, the load resistances loading each transmission-line section vary (geometrically) about the characteristic impedance of the lines, which helps reduce required transmission-line reflection and loss. This design choice provides a compressed input resistance having a range of values determined by the load resistances. In cases where this range of input resistance values is not what is desired for the system, an additional impedance transformation stage may be placed at the input of the TLRCN. One highly effective means to do this is to add an additional quarter-wave line at the input to the compression stage (referred to herein as the compression port), as illustrated in FIG. **10D**.

The whole transmission-line structure of FIG. **10D** is likewise itself a resistance compression network having both a compression stage and a transformation stage. The quarter wave line is selected to have a characteristic impedance Z_T that provides an impedance transformation between the resistance obtained at the input of the compression stage (e.g., $Z_{in,median}$, the median of the range of the input resistance Z_{in} or a similar value related to Z_{in}) and that desired for the input

of the system ($Z_{in,T}$). In this case, to obtain an overall input resistance near a desired value $Z_{in,T,desired}$ we may select:

$$Z_T = \sqrt{Z_{in,T,desired} Z_{in,median}} \quad (9)$$

Another design approach takes advantage of the freedom to choose both the differential length and the characteristic impedance of the transmission lines. One can also choose the base length. In the example that follows, a base length of $\theta_{base} = \pi/2$ radians at the operating frequency will be used. By properly selecting the differential length and the characteristic impedance, within certain bounds, one can directly realize both resistance compression and a desired specified input resistance directly with the structure of FIG. 10A. In this design approach, one may start with a center resistance $R_{L,center}$ about which load resistances are compressed. For balanced compression, $R_{L,center}$ is chosen as the geometric mean of the maximum and minimum load resistances, $R_{L,max}$ and $R_{L,min}$. A desired minimum input resistance $R_{in,min}$ of any value below $R_{L,center}$ may then be chosen. The input resistance will take on values at and above $R_{in,min}$, with the range of R_{in} values depending on the range of the R_L values as per Equation (7). One option is to select $R_{in,min}$ to be the desired resistance $R_{in,desired}$ seen at the input of the TLRCN (recognizing that the actual input resistance will be at or above the desired value). Another option is to set the median value of the input resistance that occurs over the range of load resistances to match the desired input resistance. To achieve this for a given maximum to minimum load resistance ratio, one may select $R_{in,min}$ as follows:

$$R_{in,min} = \frac{2 \cdot R_{in,desired}}{1 + \frac{1}{2} \sqrt{\frac{R_{L,max}}{R_{L,min}}} + \frac{1}{2} \sqrt{\frac{R_{L,min}}{R_{L,max}}}} \quad (10)$$

One could likewise select $R_{in,min}$ to be some other value close to $R_{in,desired}$ to achieve good results.

Based on selecting $R_{L,center}$ and $R_{in,min}$ as described above (with resistance $R_{in,min}$ necessarily selected below $R_{L,center}$), one can directly choose Z_0 and $\Delta\theta$ of the network of FIG. 10A to provide both the needed compression and impedance transformation, as follows:

$$\cot(\Delta\theta) = \sqrt{\frac{R_{L,center}}{R_{in,min}}} - 1 \quad (11)$$

$$Z_0 = \frac{R_{L,center}}{\sqrt{\frac{R_{L,center}}{R_{in,min}}} - 1} \quad (10)$$

This design choice has the advantage of providing both resistance compression and impedance transformation (where needed) in a compact structure. However, the practicality of such an implementation will depend on the desired values. For example, as $R_{in,min}$ approaches $R_{L,center}$, the characteristic impedance of the transmission line can grow unreasonably large. It should also be appreciated that one can use the selection of the transmission-line impedance and differential length to provide a first-degree of impedance transformation, and add another quarter-wave transformer at the input (and/or a set of quarter-wave transformers between the base compression stage and the loads) to provide additional impedance transformation.

As with conventional resistance compression networks, one may construct multi-stage or multi-level compression networks to provide greater degrees of resistance compression than obtained with a single-level design. As with conventional resistance compression networks, this may be done by cascading single-level resistance compression stages in a tree structure (e.g., a binary tree, etc.), though other structural implementations of multi-level TLRCNs are possible. FIG. 10E shows an exemplary two-stage TLRCN. This example utilizes $l_{base} = \lambda/4$ ($\theta_{base} = \pi/2$ radians), and differential lengths $\Delta l = \lambda/8$ ($\Delta\theta = \pi/4$) radians ($\Delta l = \lambda/8$), such that $\theta_1 = 3\pi/4$ and $\theta_2 = \pi/4$ in each stage. With this selection of differential lengths, a multi-stage TLRCN can be optimized (in terms of minimizing the peak deviation from a median input resistance) just as with conventional reactance-based multi-level RCNs (see, e.g., "A New Power Combining and Outphasing Modulation System for High-Efficiency Power Amplification," by Perreault et al., *IEEE Transactions on Circuits and Systems—I*, Vol. 58, No. 8, pp. 1713-1726, August 2011; and U.S. Patent Publication No. 2011/0187437 to Perreault et al., entitled "Radio-Frequency (RF) Amplifier Circuits and Related Techniques," which is hereby incorporated by reference in its entirety), with the transmission-line characteristic impedances of the lines in the two stages taking the place of the reactance amplitudes of the two stages. Alternatively, both the characteristic impedances and the base and differential lengths of each stage can be optimized to provide an overall desired input resistance level and transformation, with the opportunity to achieve additional goals through the parameter selection, such as minimizing RCN loss. Although illustrated with two stages in FIG. 10E, it should be appreciated that additional stages may be added to provide further resistance compression.

Combining a transmission-line resistance compression network with a set of rectifiers forms a resistance compressed rectifier system. An exemplary resistance-compressed rectifier system 520 incorporating a TLRCN is shown in FIG. 10F. This system is for 2.14 GHz operation, and has four tuned rectifiers as loads for the TLRCN that act as approximately resistive loads, each providing ac input impedance of $\sim 24-160\Omega$ over an input power range of 0.125-1.07 W (and a dc rectifier output power of 0.08-0.85 W) at a rectifier output voltage of 7 V. The rectifier also includes a series-resonant input filter, and is tuned for resistive operation by appropriate resonance between the device capacitance and output inductance. Note that these filtering and tuning elements can be provided as discrete components or constructed in a printed circuit board (optionally including elements such as transmission-line sections, gap capacitors, etc.). The TLRCN has two compression stages and a transformation stage. The first compression-stage "A" compresses the resistances presented by the rectifiers into a range of 31-46 Ω (for the first-stage input impedances $Z_{in,A1}$ and $Z_{in,A2}$, which act as the load for the second stage of compression). The second stage further compresses this to an input impedance $Z_{in,B}$ of approximately 19-19.4 Ω resistive over the rectifier load resistance range. The transformation stage, comprising a quarter-wave line, transforms this impedance into the overall input impedance of approximately 50 Ω .

It will be appreciated that the inventive energy recovery system can be employed in numerous other applications in which energy is conventionally delivered to a resistive termination. By replacing the lossy termination with the energy recovery system, the power that would otherwise be lost can be captured and converted to a useful form, while maintaining a desirable loading characteristic at the termination point.

21

Having described exemplary embodiments of the invention, it will now become apparent to one of ordinary skill in the art that other embodiments incorporating their concepts may also be used. The embodiments contained herein should not be limited to disclosed embodiments but rather should be limited only by the spirit and scope of the appended claims. All publications and references cited herein are expressly incorporated herein by reference in their entirety.

What is claimed is:

1. A resistance compression network to shape an input impedance at a port for transferring energy to multiple loads at a first frequency, the resistance compression network comprising:

- a first transmission line segment having a first electrical length at the first frequency, the first transmission line segment having an output for coupling to a first load;
- a second transmission line segment having a second electrical length at the first frequency, the second electrical length being different from the first electrical length, the second transmission line segment having an output for coupling to a second load; and
- a compression port coupled to inputs of both the first and the second transmission line segments;

wherein, over a set of operating conditions of interest, an equivalent resistance looking into the compression port at the first frequency varies over a first resistance range as equivalent resistances of the first and second loads vary over a second resistance range, wherein a range ratio associated with the first resistance range is less than a range ratio associated with the second resistance range, wherein the range ratio of a subject range is a ratio of a largest resistance value in the subject range to a smallest resistance value in the subject range.

2. The resistance compression network of claim 1, wherein:

the first and second loads have input impedances that vary in substantially the same manner under similar conditions.

3. The resistance compression network of claim 1, wherein:

the first and second loads have input impedances that are approximately resistive at the first frequency.

4. The resistance compression network of claim 1, wherein:

the first and second transmission line segments each have substantially the same characteristic impedance Z_0 .

5. The resistance compression network of claim 4, wherein:

the first transmission line segment has an electrical length of $\pi/2+N\pi+\Delta\theta$ radians and the second transmission line segment has an electrical length of $\pi/2+M\pi-\Delta\theta$ radians, where $N, M \in [0, 1, 2, \dots]$.

6. The resistance compression network of claim 5, wherein:

the resistance range of the first and second loads at the first frequency has a lower bound $R_{L,min}$, an upper bound $R_{L,max}$, and a center value $R_{L,center}$ that is the geometric mean of $R_{L,min}$ and $R_{L,max}$; and

the characteristic impedance Z_0 of the first and second transmission line segments is approximately:

$$Z_0 = R_{L,center} / |\cot(\Delta\theta)|.$$

22

7. The resistance compression network of claim 4, wherein:

the first transmission line segment has an electrical length of $\pi+N\pi+\Delta\theta$ radians and the second transmission line segment has an electrical length of $\pi+M\pi-\Delta\theta$ radians, where $N, M \in [0, 1, 2, \dots]$.

8. The resistance compression network of claim 7, wherein:

the resistance range of the first and second loads at the first frequency has a lower bound $R_{L,min}$, an upper bound $R_{L,max}$, and a center value $R_{L,center}$ that is the geometric mean of $R_{L,min}$ and $R_{L,max}$; and

the characteristic impedance Z_0 of the first and second transmission line segments is approximately:

$$Z_0 = R_{L,CENTER} / |\tan(\Delta\theta)|.$$

9. The resistance compression network of claim 1, wherein:

the first and second transmission line segments have different characteristic impedances.

10. The resistance compression network of claim 1, wherein:

the resistance compression network is configured to provide substantially the same power to the first and second loads if the first and second loads have substantially the same impedance.

11. The resistance compression network of claim 1, wherein:

the resistance compression network is configured for use with loads that include rectifier circuits.

12. The resistance compression network of claim 1, further comprising:

a quarter-wave transformer coupled to the compression port to transform the impedance looking into the compression port.

13. The resistance compression network of claim 1, wherein:

the compression port is a first compression port; and the resistance compression network further comprises:

a third transmission line segment having a third electrical length at the first frequency, the third transmission line segment having an output for coupling to a third load;

a fourth transmission line segment having a fourth electrical length at the first frequency, the fourth electrical length being different from the third electrical length, the fourth transmission line segment having an output for coupling to a fourth load; and

a second compression port coupled to inputs of the third and fourth transmission line segments;

wherein, over the set of operating conditions of interest, an equivalent resistance looking into the second compression port at the first frequency varies over a third resistance range as equivalent resistances of the third and fourth loads vary over a fourth resistance range, wherein a range ratio associated with the third resistance range is less than a range ratio associated with the fourth resistance range.

14. The resistance compression network of claim 13, further comprising:

a fifth transmission line segment having a fifth electrical length at the first frequency, the fifth transmission line segment having an output coupled to the first compression port;

a sixth transmission line segment having a sixth electrical length at the first frequency, the sixth electrical length being different from the fifth electrical length, the sixth

23

transmission line segment having an output coupled to the second compression port; and
a third compression port coupled to inputs of the fifth and sixth transmission line segments;

wherein, over the set of operating conditions of interest, an equivalent resistance looking into the third compression port at the first frequency varies over a fifth resistance range as equivalent resistances at the first and second compression ports vary over the first and third resistance ranges, respectively, wherein a range ratio associated with the fifth resistance range is less than range ratios associated with the first and third resistance ranges.

15. The resistance compression network of claim 14, further comprising:
a quarter wave transformer coupled to the third compression port.

16. The resistance compression network of claim 13, wherein:
the resistance compression network is configured for use with loads having input impedances that vary in substantially the same manner under similar conditions.

24

17. The resistance compression network of claim 13, wherein:

- the third electrical length is substantially equal to the first electrical length; and
- the fourth electrical length is substantially equal to the second electrical length.

18. The resistance compression network of claim 14, wherein:

- the fifth electrical length is substantially equal to the first electrical length;
- the sixth electrical length is substantially equal to the second electrical length;
- the characteristic impedances of the first, second, third, and fourth transmission line segments are substantially the same; and
- the characteristic impedances of the fifth and sixth transmission line segments are substantially the same as each other, but different from the characteristic impedances of the first, second, third, and fourth transmission line segments.

* * * * *