



US008451053B2

(12) **United States Patent**
Perreault et al.

(10) **Patent No.:** **US 8,451,053 B2**
(45) **Date of Patent:** **May 28, 2013**

(54) **RADIO-FREQUENCY (RF) AMPLIFIER CIRCUITS AND RELATED TECHNIQUES**

(75) Inventors: **David J. Perreault**, Brookline, MA (US); **Alexander S. Jurkov**, Cambridge, MA (US)

(73) Assignee: **Massachusetts Institute of Technology**, Cambridge, MA (US)

(*) Notice: Subject to any disclaimer, the term of this patent is extended or adjusted under 35 U.S.C. 154(b) by 30 days.

(21) Appl. No.: **13/020,568**

(22) Filed: **Feb. 3, 2011**

(65) **Prior Publication Data**

US 2011/0187437 A1 Aug. 4, 2011

Related U.S. Application Data

(60) Provisional application No. 61/300,963, filed on Feb. 3, 2010.

(51) **Int. Cl.**
H03F 3/68 (2006.01)

(52) **U.S. Cl.**
USPC **330/124 R**

(58) **Field of Classification Search**
USPC 330/53, 84, 124 R, 295
See application file for complete search history.

(56) **References Cited**

U.S. PATENT DOCUMENTS

4,129,839	A	12/1978	Galani et al.	
4,835,493	A	5/1989	Walsh, Jr.	
5,012,200	A *	4/1991	Meinzer	330/124 R
6,825,719	B1 *	11/2004	Barak et al.	330/124 R
7,279,971	B2 *	10/2007	Hellberg et al.	330/124 R

7,411,449	B2 *	8/2008	Klingberg et al.	330/124 R
7,535,133	B2	5/2009	Perreault et al.	
7,956,572	B2	6/2011	Zane et al.	
2005/0248401	A1	11/2005	Hellberg et al.	
2011/0135035	A1	6/2011	Bose et al.	

FOREIGN PATENT DOCUMENTS

WO WO 2009/153218 A1 12/2009

OTHER PUBLICATIONS

Xu, et al.; "A 28.1dBm class-D outphasing power amplifier in 45nm LP digital CMOS," Symposium on VLSI Circuits Digest of Technical Papers; Jun. 16, 2009; pp. 206-207.

Zhou, et al.; "A Distributed Active Transformer Coupled Outphasing Power Combiner," Microwave Conference, IEEE; Dec. 7, 2009; pp. 2565-2568.

PCT Search Report of the ISA for PCT/US2011/023613 dated May 30, 2011.

Written Opinion of the ISA for PCT/US2011/023613 dated May 30, 2011.

Beltran, et al.; "HF Outphasing Transmitter Using Class-E Power Amplifiers," Microwave Symposium Digest, IEEE; Jun. 2009; pp. 757-760.

(Continued)

Primary Examiner — Khanh V Nguyen

(74) *Attorney, Agent, or Firm* — Daly, Crowley, Mofford & Durkee, LLP

(57) **ABSTRACT**

A power combining and outphasing system and related techniques for simultaneously providing both wide-bandwidth linear amplification and high average efficiency is described. Providing linear amplification encompasses the ability to dynamically control an RF output power level over a wide range while still operating over a wide frequency bandwidth. The system and techniques described herein also operate to maintain high efficiency across a wide range of output power levels, such that a high average efficiency can be achieved for highly modulated output waveforms.

32 Claims, 36 Drawing Sheets

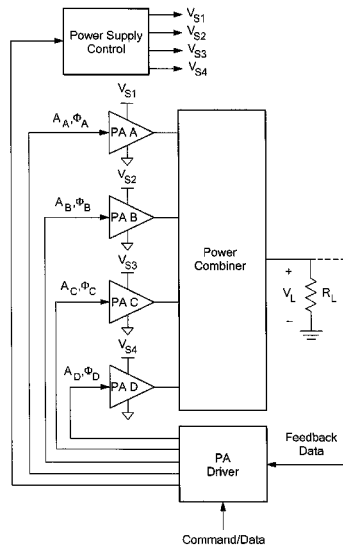

OTHER PUBLICATIONS

- Bifrane, et al.; "On the Linearity and Efficiency of Outphasing Microwave Amplifiers;" IEEE Transactions on Microwave Theory and Techniques; vol. 52; No. 7; Jul. 2004; pp. 1702-1708.
- Chen, et al.; "A High Efficiency Outphasing Transmitter Structure for Wireless Communications;" Digital Signal Processing Workshop, IEEE; Jan. 2009, pp. 348-352.
- Chireix; "High Power Outphasing Modulation;" Proceedings of the Institute of Radio Engineers; vol. 23; No. 11; Nov. 1935; pp. 1370-1392.
- Cox; "Linear Amplification with Nonlinear Components;" IEEE Transactions on Communications; Dec. 1974; pp. 1942-1945.
- El-Hamamsy; "Design of High-Efficiency RF Class-D Power Amplifier;" IEEE Transactions on Power Electronics; vol. 9; No. 3; May 1994; pp. 297-308.
- Eun, et al.; "A High Linearity Chireix Outphasing Power Amplifier Using Composite Right/Left-Handed Transmission Lines;" Proceedings of the 37th European Microwave Conference; Oct. 2007; pp. 1622-1625.
- Everitt, et al.; "Communication Engineering;" 3rd Edition, Chapter 11, pp. 403-450, New York: McGraw-Hill, 1956.
- Gerhard, et al.; "Improved Design of Outphasing Power Amplifier Combiners;" 2009 German Microwave Conference; Mar. 2009; pp. 1-4.
- Godoy, et al.; "Outphasing Energy Recovery Amplifier With Resistance Compression for Improved Efficiency;" IEEE Transactions on Microwave Theory and Techniques; vol. 57; No. 12; Dec. 2009; pp. 2895-2906.
- Hakala, et al., "A 2.14-GHz Chireix Outphasing Transmitter;" IEEE Transactions on Microwave Theory and Techniques; vol. 53; No. 6; Jun. 2005; pp. 2129-2138.
- Hakala, et al.; Chireix Power Combining with Saturated Class-B Power Amplifiers; 12th GAAS Symposium; Oct. 2004, pp. 379-382.
- Hamill; "Impedance Plan Analysis of Class DE Amplifier;" Electronics Letters; vol. 30; No. 23; Nov. 10, 1994; pp. 1905-1906.
- Hamill; "Time Reversal Duality Between Linear Networks;" IEEE Transactions on Circuits and Systems-I: Fundamental Theory and Applications; vol. 43; No. 1; Jan. 1996; pp. 63-65.
- Hamill; "Time Reversal Duality in Dc-Dc Converters;" Power Electronics Specialists Conference, IEEE; vol. 1; Jun. 1997; 7 pages.
- Han, et al.; "Analysis and Design of High Efficiency Matching Networks;" IEEE Transactions on Power Electronics; vol. 21; No. 5, Sep. 2006; pp. 1484-1491.
- Han, et al.; "Resistance Compression Networks for Radio-Frequency Power Conversion;" IEEE Transactions on Power Electronics; vol. 22; No. 1; Jan. 2007; pp. 41-53.
- Honjo; "A Simple Circuit Synthesis Method for Microwave Class-F Ultra-High-Efficiency Amplifiers with Reactance-Compensation Circuits;" Solid-State Electronics 44; Feb. 2000; pp. 1477-1482.
- Hur, et al.; "A Multi-Level and Multi-Band Class-D CMOS Power Amplifier for the LINC System in the Cognitive Radio Application;" IEEE Microwave and Wireless Components Letters; vol. 20; Issue 6; Jun. 2010; pp. 1-3.
- Hur, et al.; "Highly Efficient and Linear Level Shifting Digital LINC Transmitter with a Phase Offset Cancellation;" Radio & Wireless Symposium; Jan. 2009; pp. 211-214.
- Hur, et al.; "Highly Efficient Uneven Multi-Level LINC Transmitter;" Electronics Letters; Jul. 30, 2009; vol. 45; No. 16; 2 pages.
- Kee, et al.; "The Class-E/F Family of ZVS Switching Amplifiers;" IEEE Transactions on Microwave Theory and Techniques; vol. 51; No. 6; Jun. 2003; pp. 1677-1690.
- Kruass, et al.; *Solid State Radio Engineering*; Chapter 14, New York: Wiley, 1980.
- Langridge, et al.; "A Power Re-Use Technique for Improved Efficiency of Outphasing Microwave Power Amplifiers;" IEEE Transactions on Microwave Theory and Techniques; vol. 47; No. 8; Aug. 1999; pp. 1467-1470.
- Lee; "Planar Microwave Engineering;" Chapter 20, pp. 630-687, New York: Cambridge University Press, 2004.
- Lepine, et al.; "L-Band LDMOS Power Amplifiers Based on an Inverse Class-F Architecture;" IEEE Transactions on Microwave Theory and Techniques; vol. 53; No. 6; Jun. 2005; pp. 2007-2012.
- Ni, et al.; "A New Impedance Match Method in Serial Chireix Combiner;" 2008 Asia-Pacific Microwave Conference; Dec. 2008; pp. 1-4.
- Perreault; A New Power Combining and Outphasing Modulation System for High-Efficiency Power Amplification; Circuits and Systems (MWSCAS), 53rd IEEE, International Midwest Symposium; Aug. 2010; pp. 1-14.
- Phinney, et al.; "Radio-Frequency Inverters with Transmission-Line Input Networks;" IEEE Transactions on Power Electronics; vol. 22; No. 4; Jul. 2007; pp. 1154-1161.
- Qureshi, et al.; "A 90-W Peak Power GaN Outphasing Amplifier with Optimum Input Signal Conditioning;" IEEE Transactions on Microwave Theory and Techniques; vol. 57; No. 8; Aug. 2009; pp. 1925-1935.
- Raab; "Class-F Power Amplifiers with Maximally Flat Waveforms;" IEEE Transactions on Microwave Theory and Techniques; vol. 45; No. 11; Nov. 1997; pp. 2007-2012.
- Raab; "Efficiency of Outphasing RF Power-Amplifier Systems;" IEEE Transactions on Communications; vol. Com-33; No. 10; Oct. 1985; pp. 1094-1099.
- Raab, et al.; "RF and Microwave Power Amplifier and Transmitter Technologies—Part 3;" High Frequency Electronics; Sep. 2003; pp. 34-48.
- Rivas, et al.; "A High-Frequency Resonant Inverter Topology with Low-Voltage Stress;" IEEE Transactions on Power Electronics; vol. 23; No. 4; Jul. 2008; pp. 1759-1771.
- Sokal, et al.; "Class E-A New Class of High-Efficiency Tuned Single-Ended Switching Power Amplifiers;" IEEE Journal of Solid-State Circuits; vol. SC-10; No. 3; Jun. 1975; pp. 168-176.
- Sokal; "Class-E RF Power Amplifiers;" QEX; Jan./Feb. 2001; pp. 9-20.
- Yao, et al.; "Power Amplifier Selection for LINC Applications;" IEEE Transactions on Circuits and Systems-II: Express Briefs; vol. 53; No. 8; Aug. 2006; pp. 763-767.
- Zhang, et al.; "Analysis of Power Recycling Techniques for RF and Microwave Outphasing Power Amplifiers;" IEEE Transactions on Circuits and Systems-II: Analog and Digital Signal Processing; vol. 49; No. 5; May 2002; pp. 312-320.
- Zhou, et al.; "A Distributed Active Transformer Coupled Outphasing Power Combiner;" IEEE Microwave Conference; Dec. 2009; pp. 2565-2568.
- Zhukov, et al.; "Push-pull switching oscillator without commutating losses;" Poluprovodnikovye Pribory v. Tekhnike Elektrosvyazi, No. 15, Jan. 1975, 8 pages.
- International Preliminary Report on Patentability of the ISA for PCT/US2011/023613 dated Aug. 16, 2012.

* cited by examiner

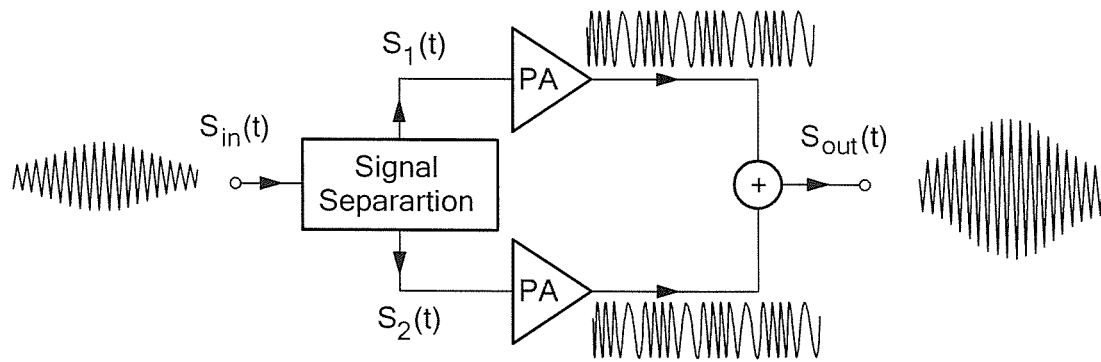

FIG. 1
(Prior Art)

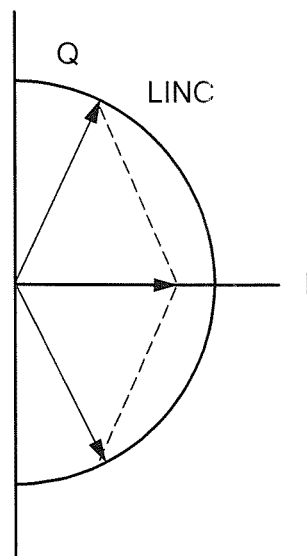

FIG. 1A

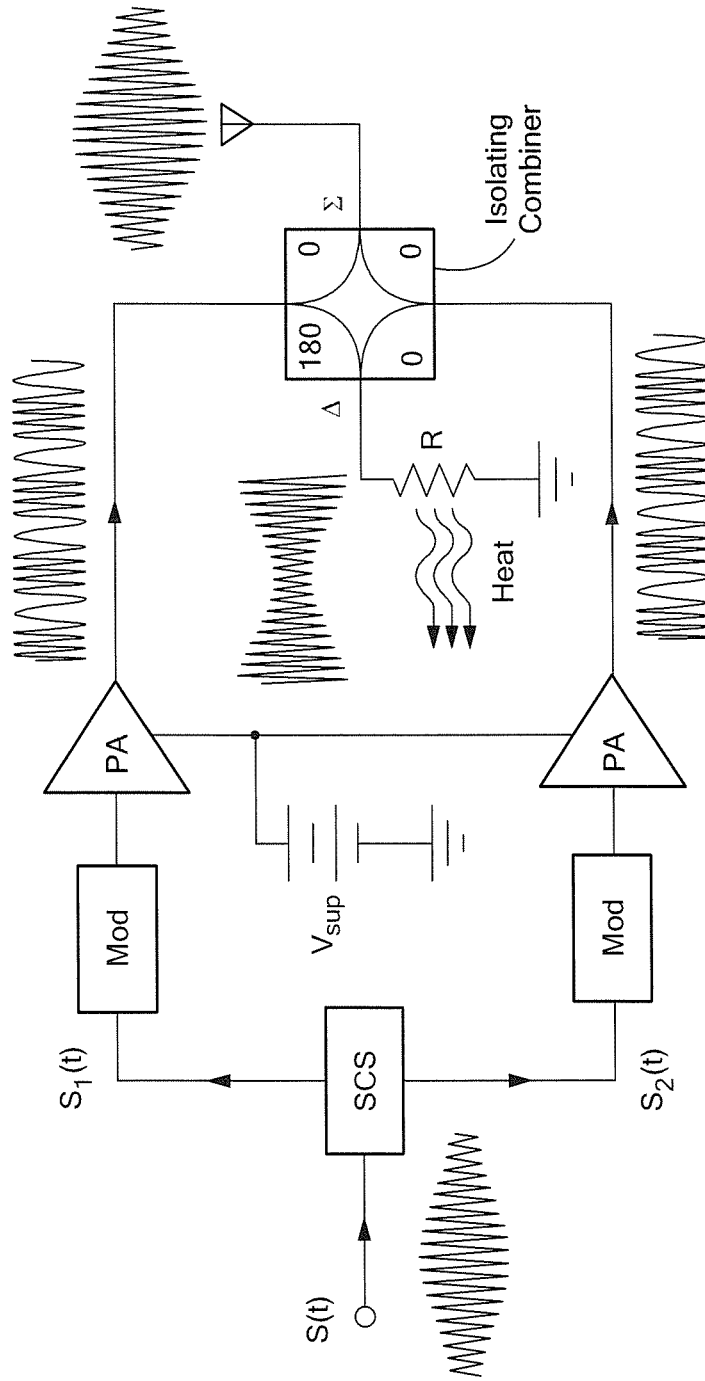

FIG. 2
(Prior Art)

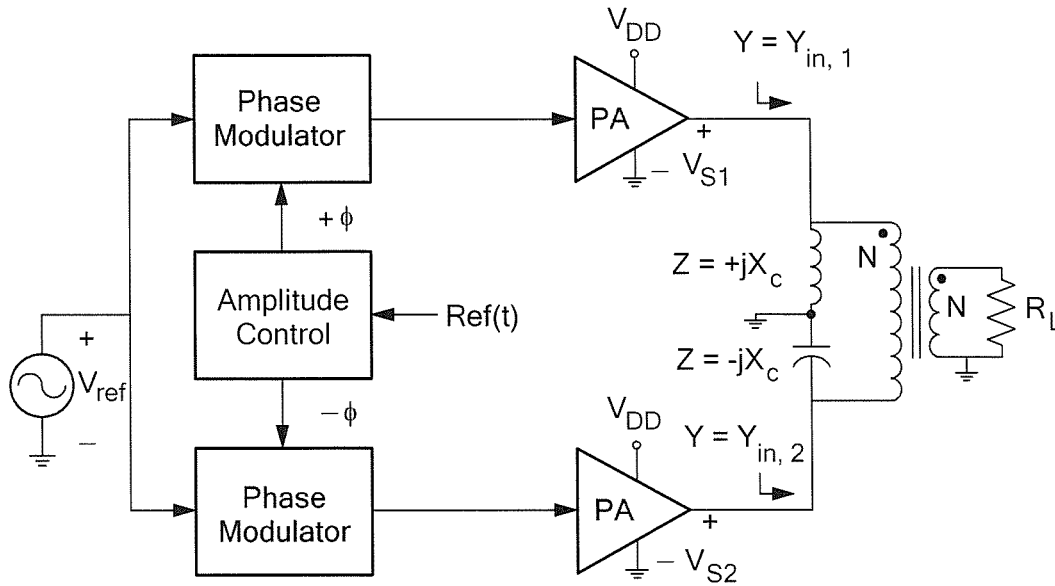

FIG. 3

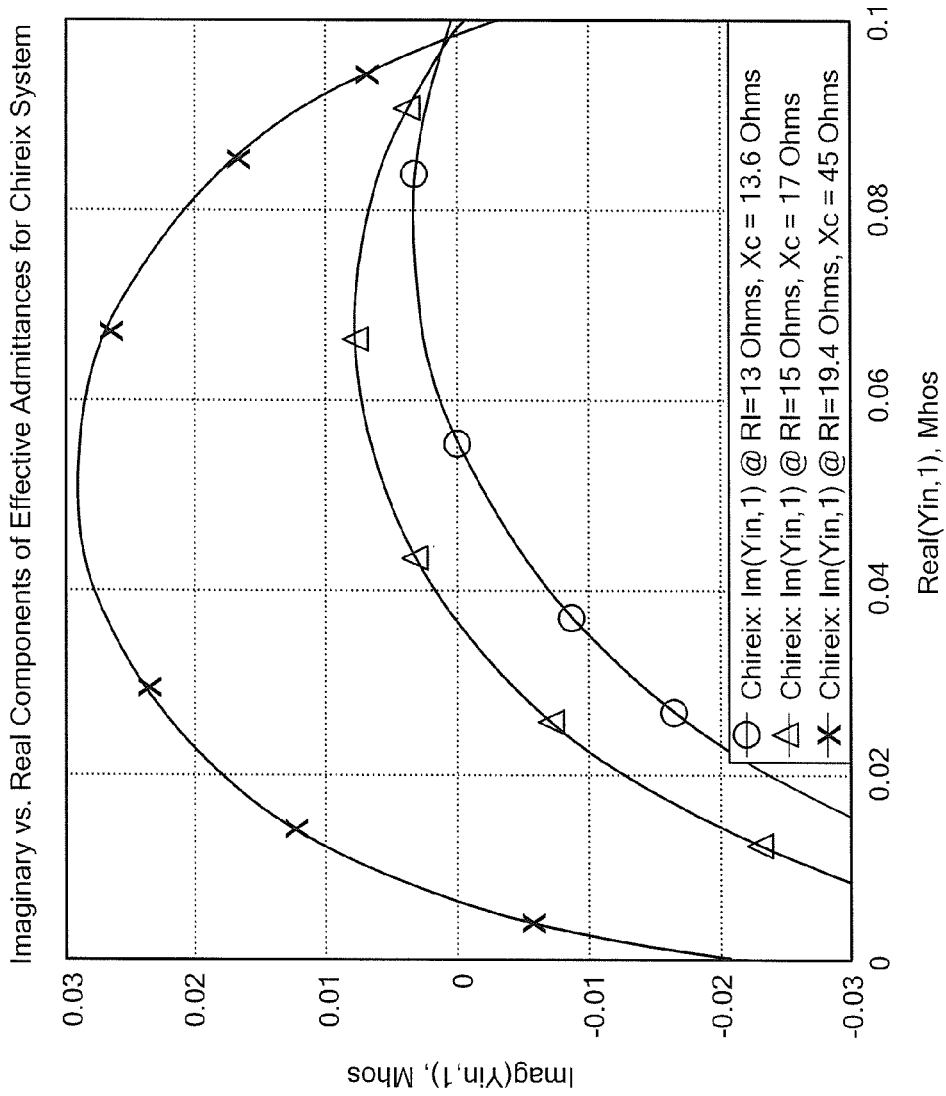

FIG. 3A

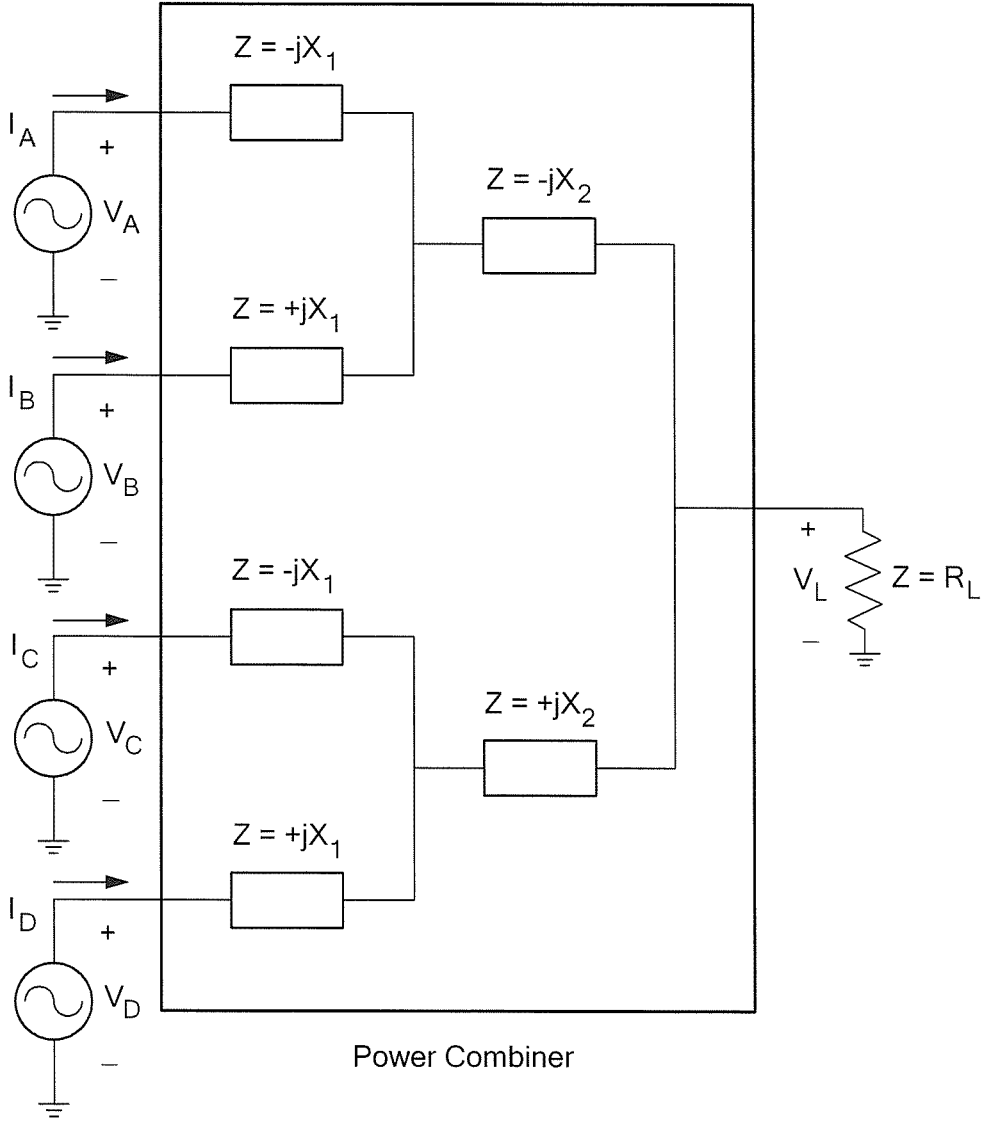

FIG. 4

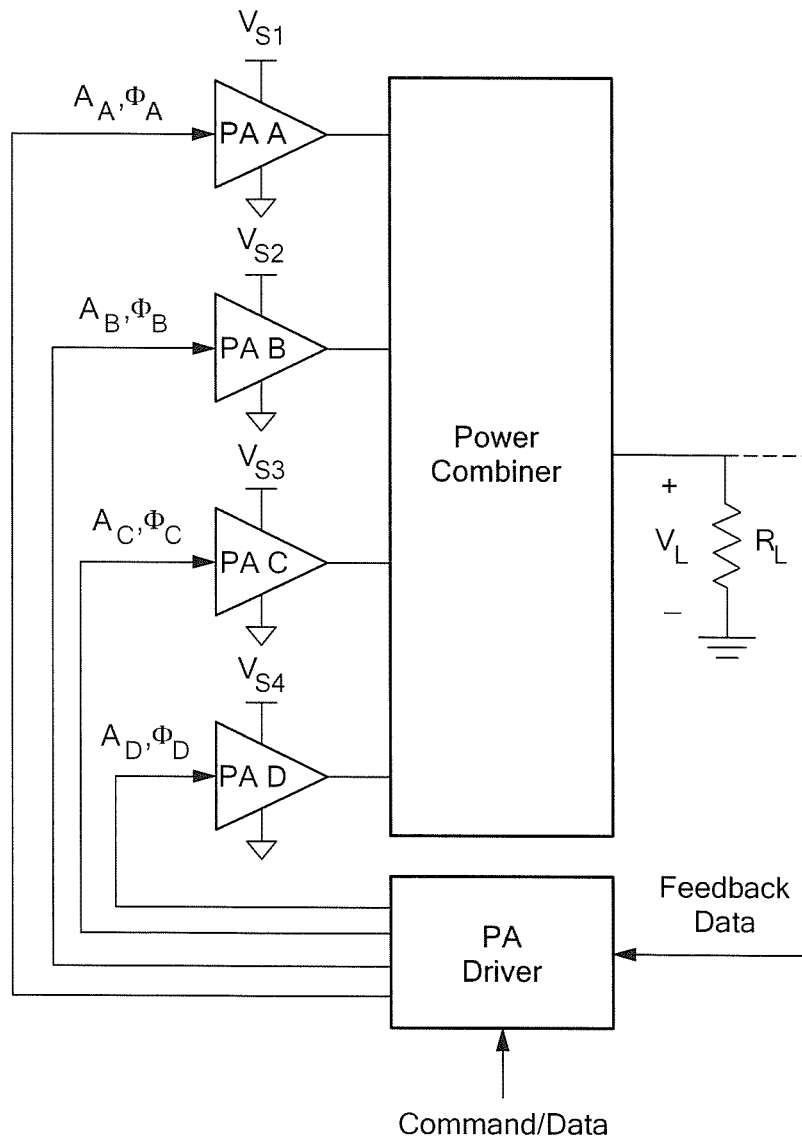

FIG. 4A

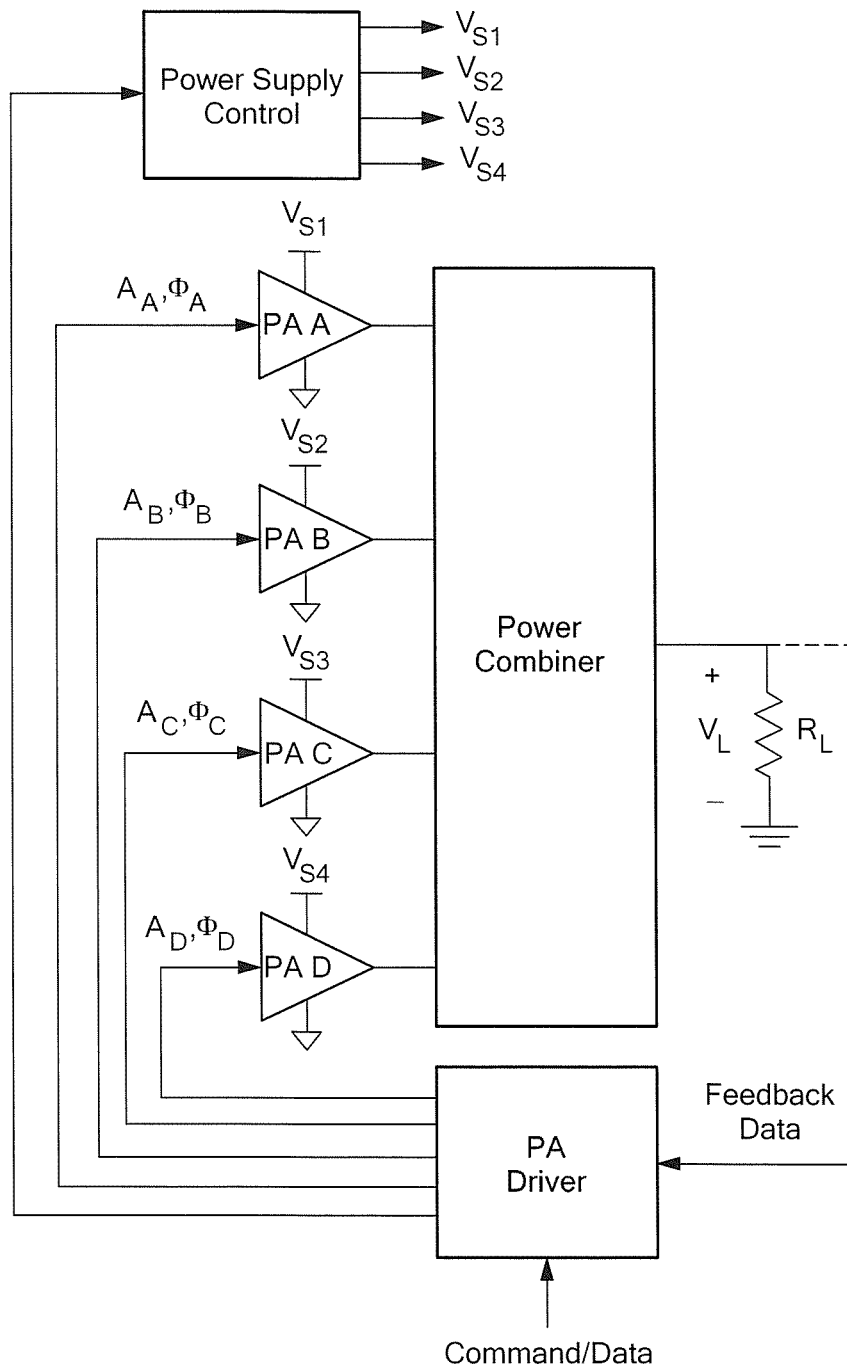

FIG. 4B

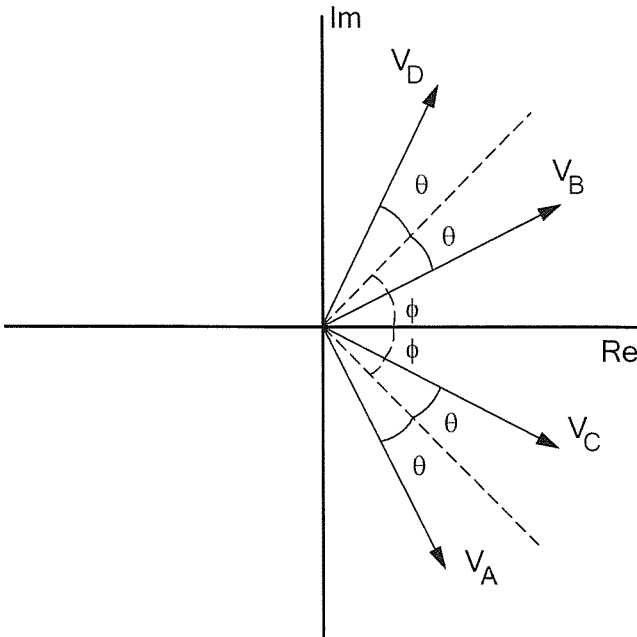

FIG. 5

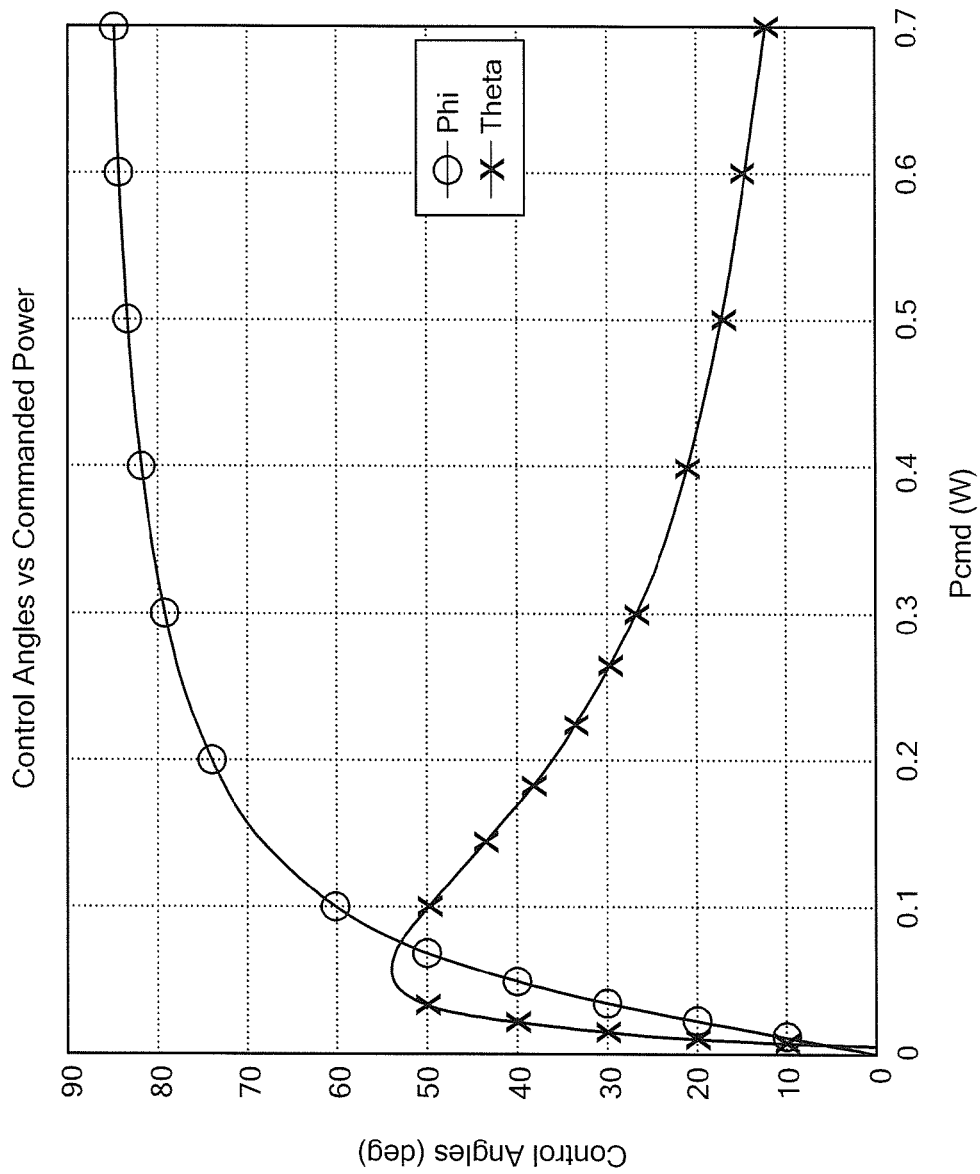

FIG. 6

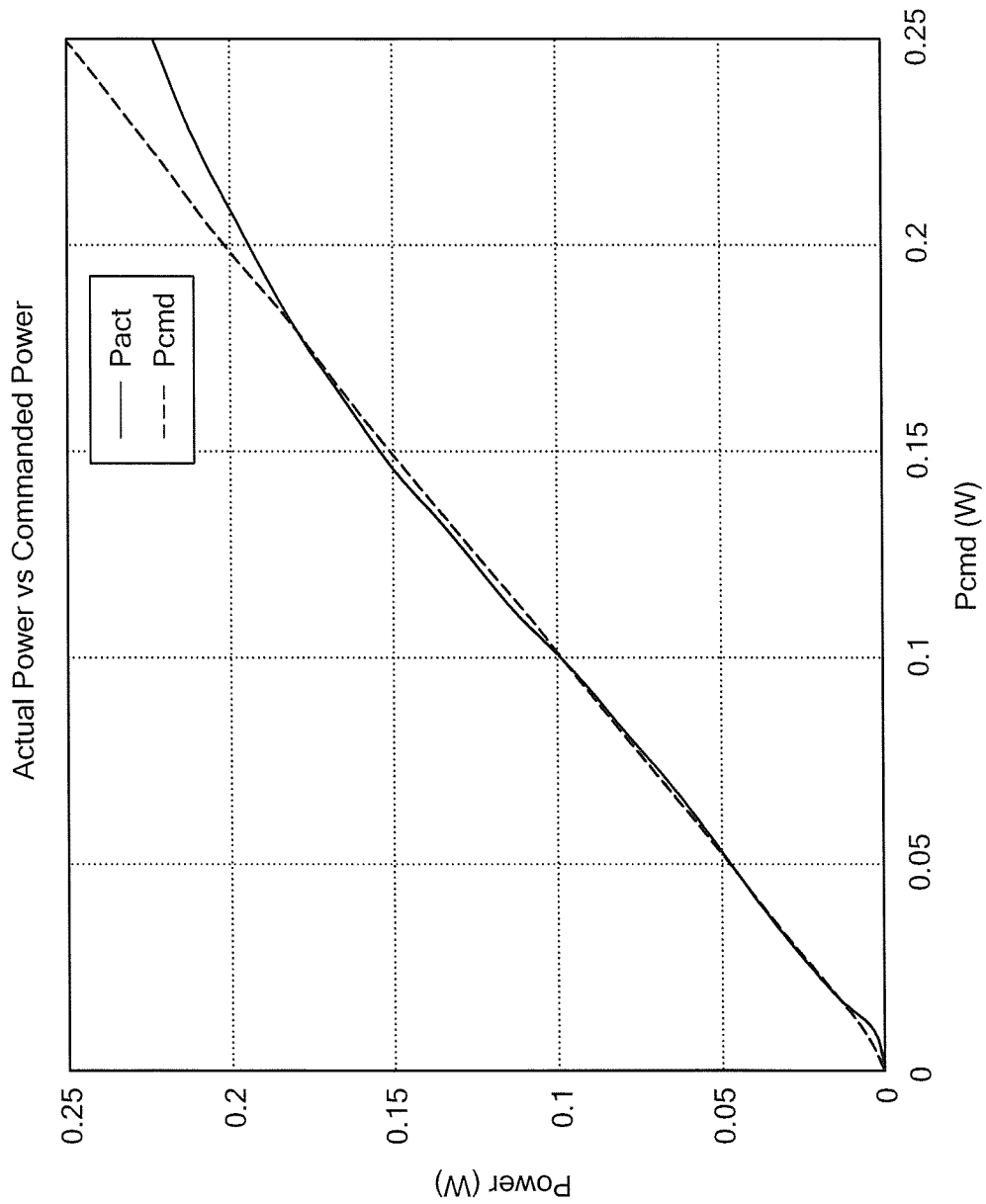

FIG. 7

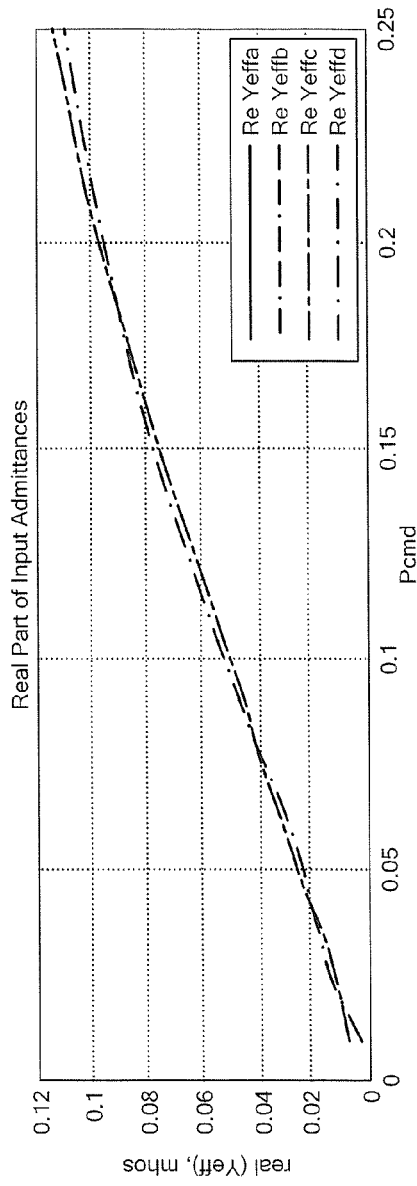

FIG. 8

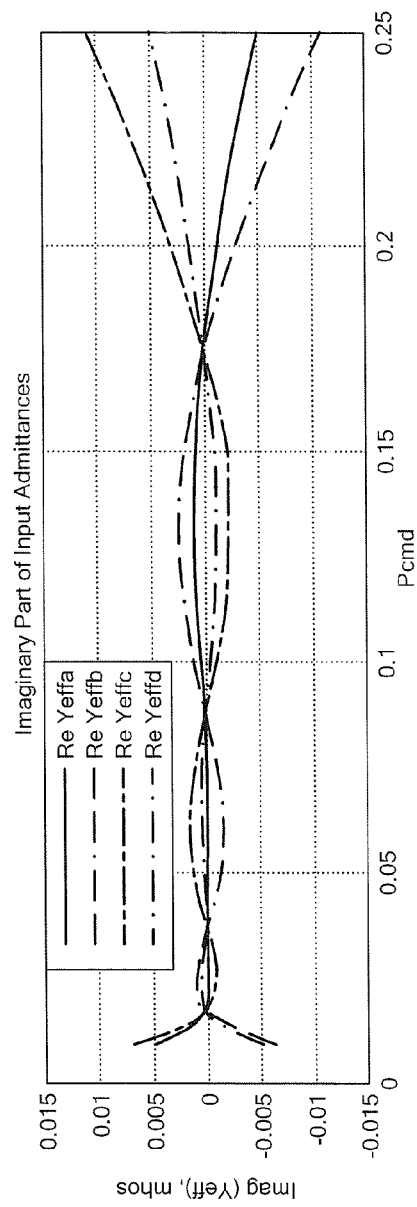

FIG. 8A

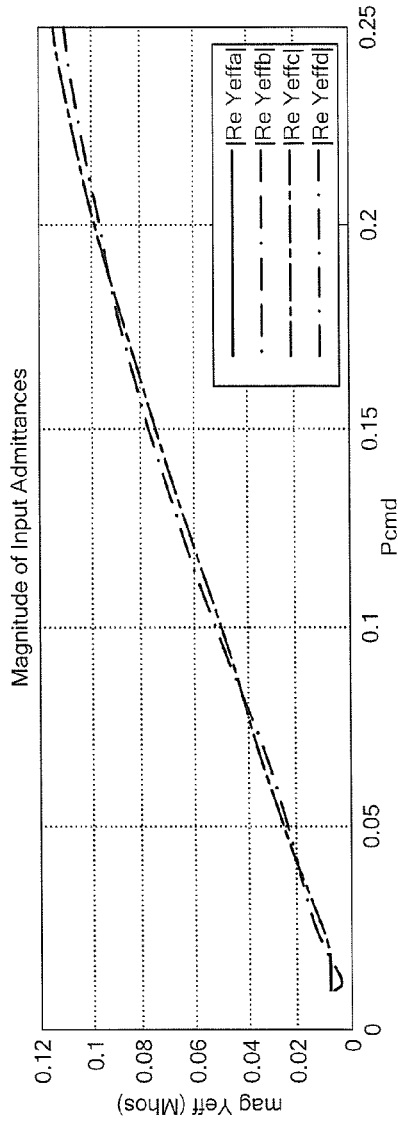

FIG. 9

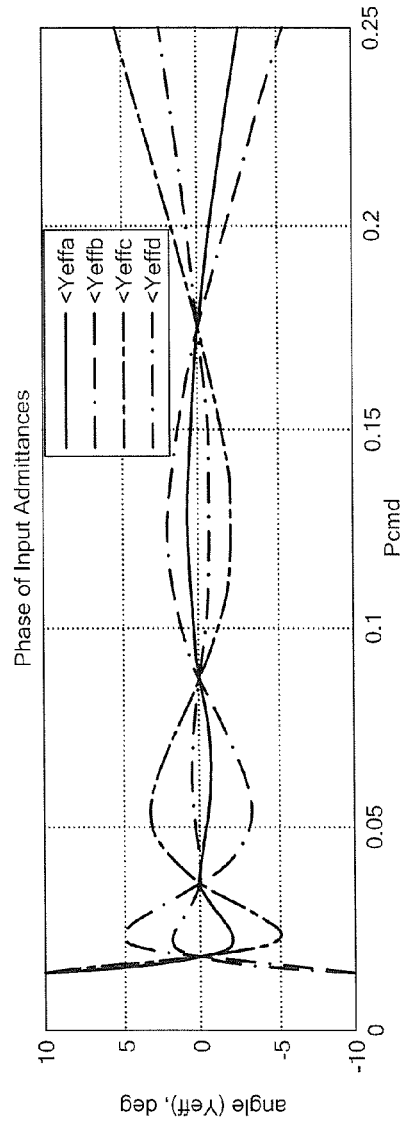

FIG. 9A

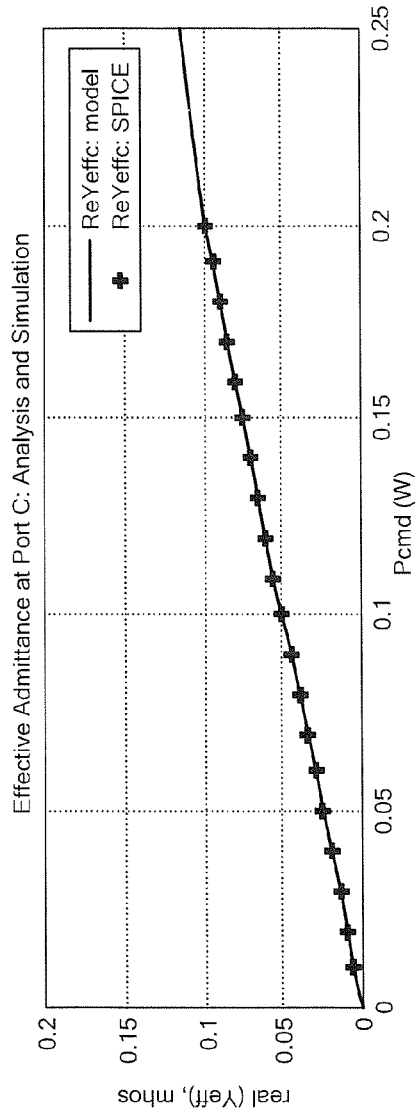

FIG. 10

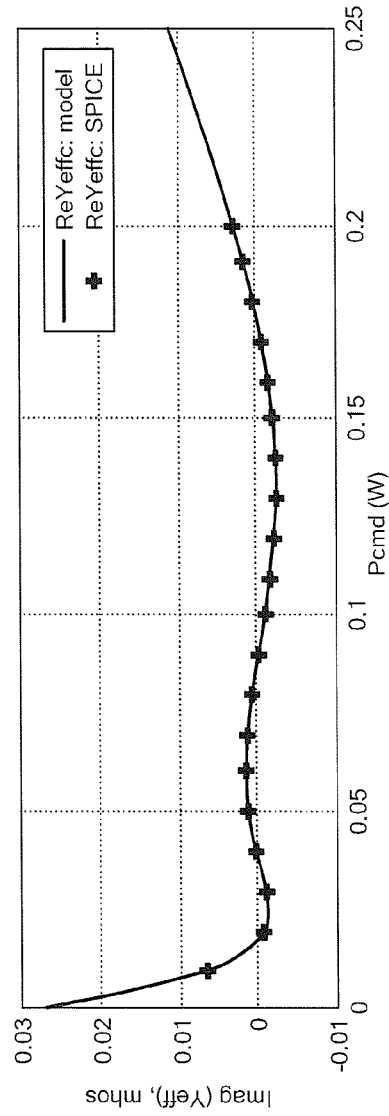

FIG. 10A

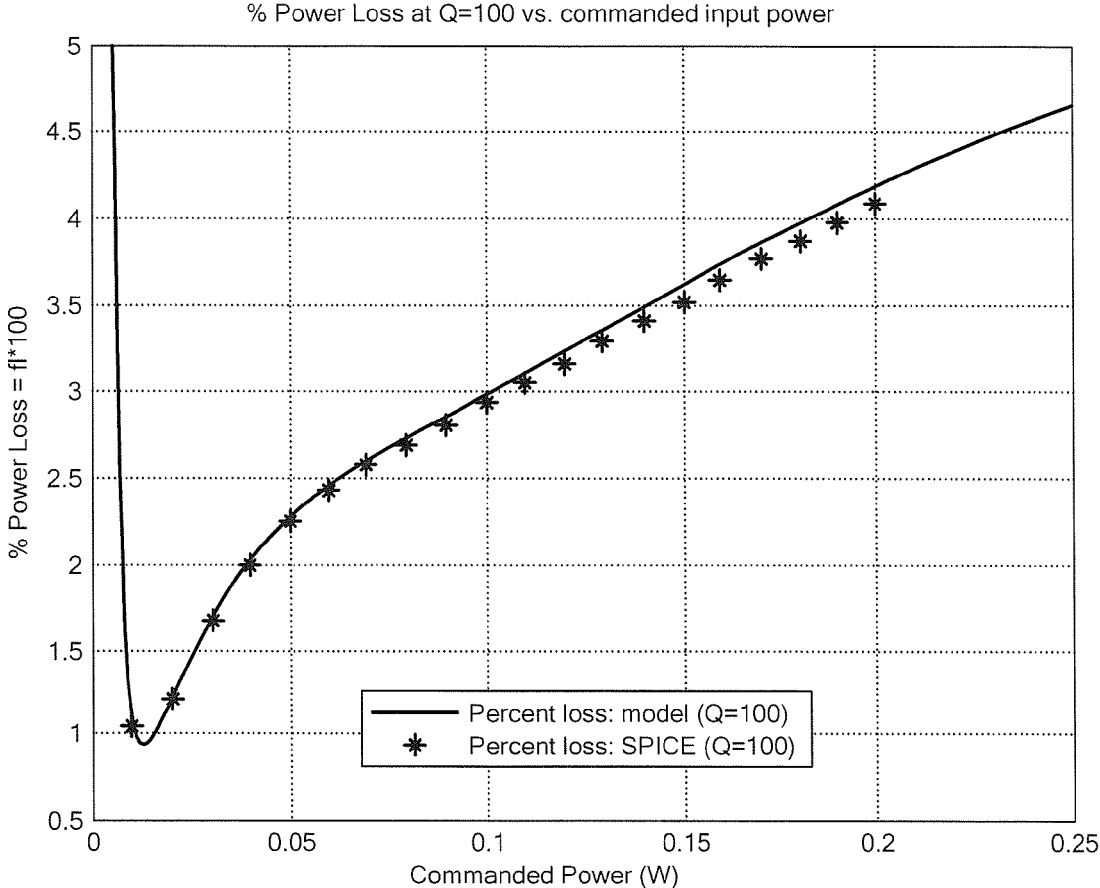

FIG. 11

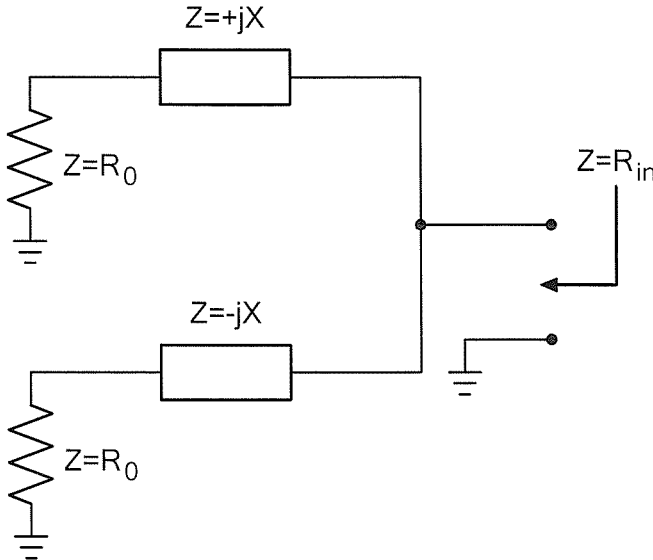

FIG. 12

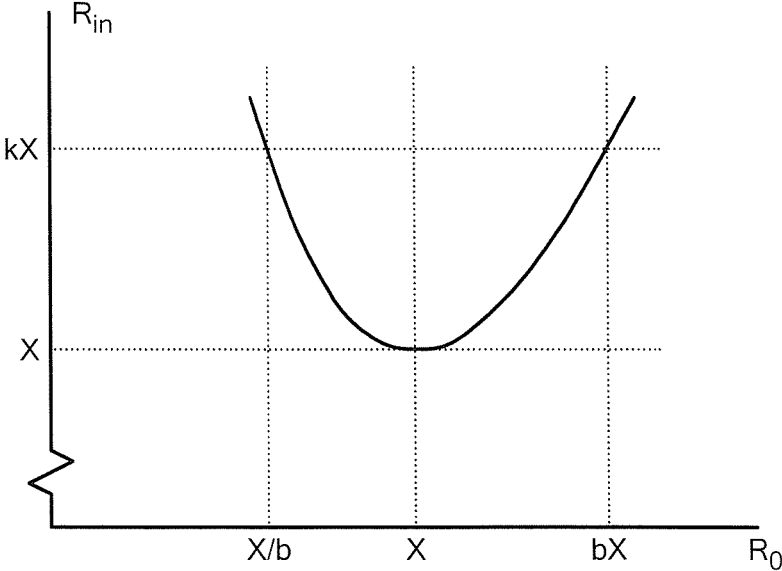

FIG. 12A

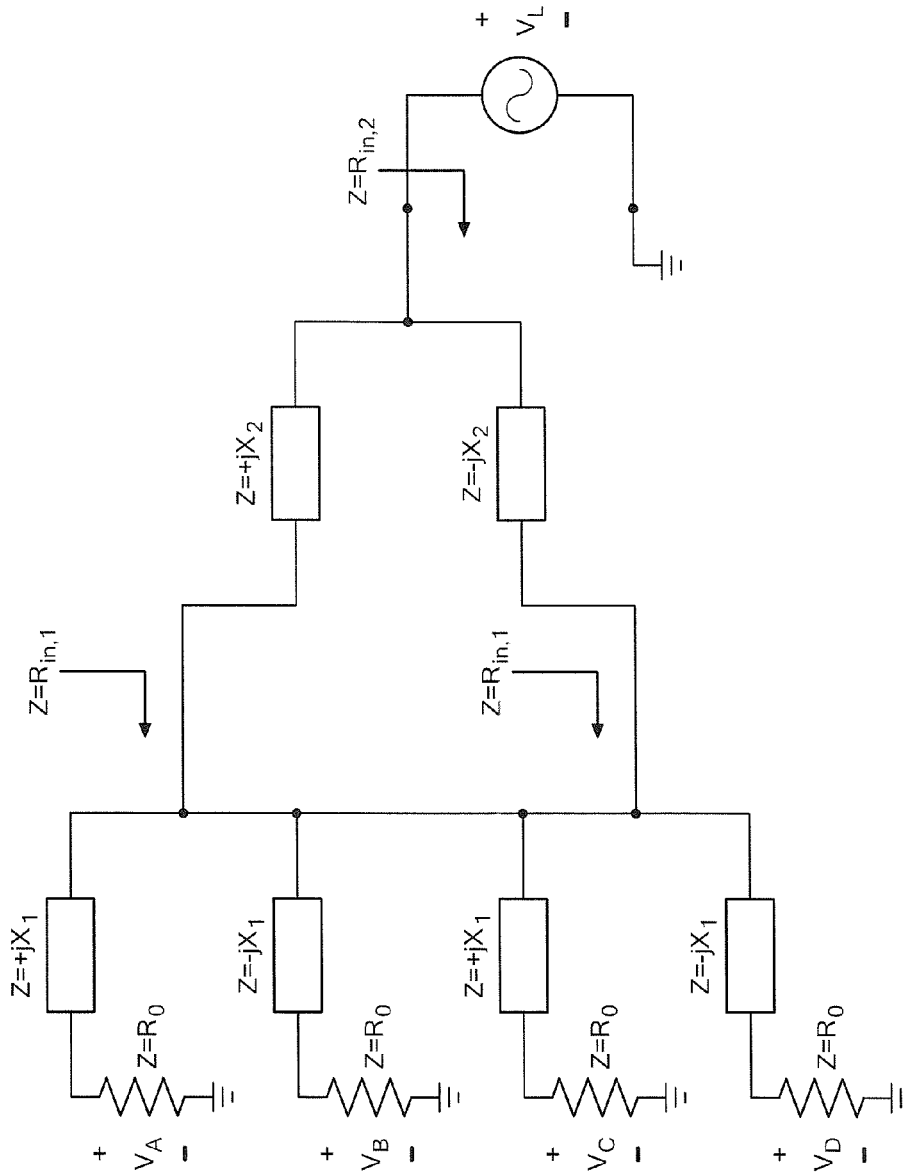

FIG. 13

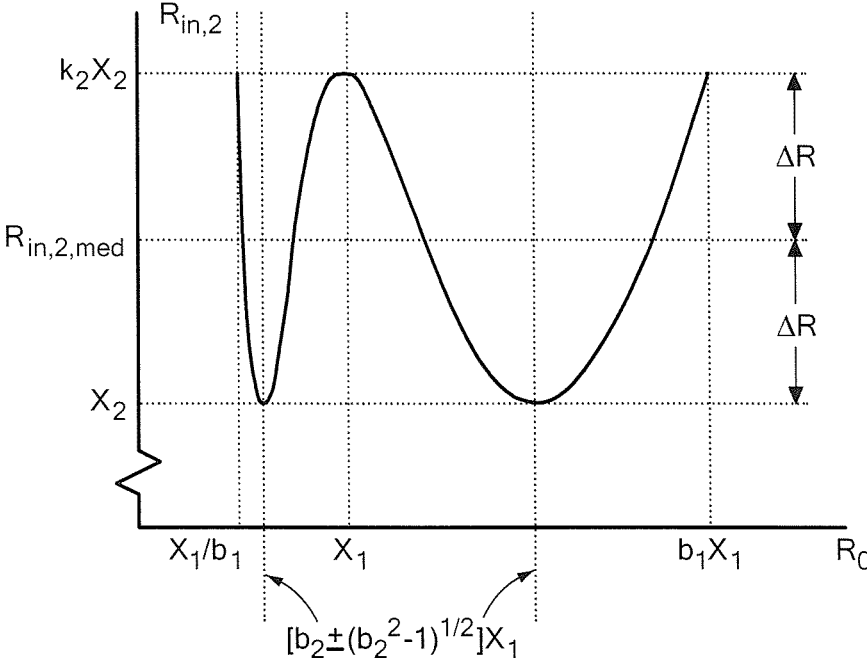

FIG. 14

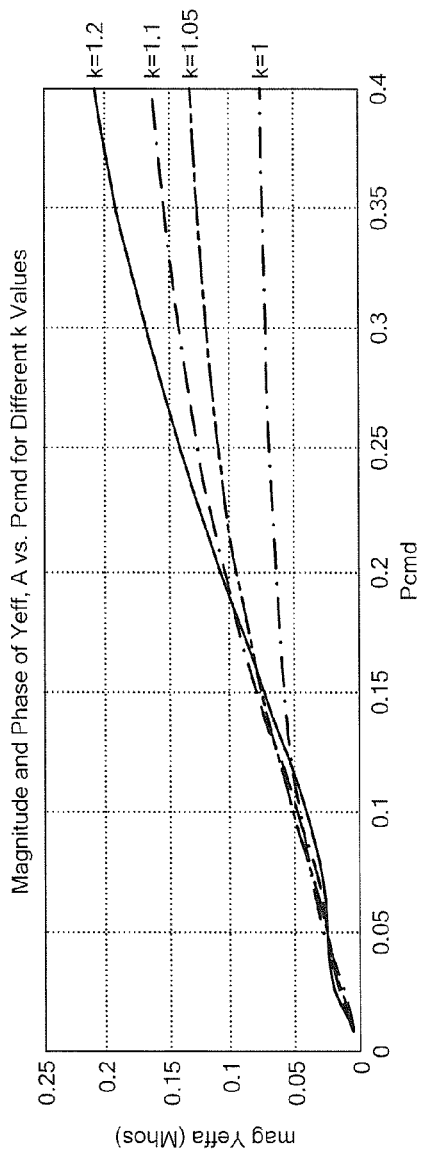

FIG. 15

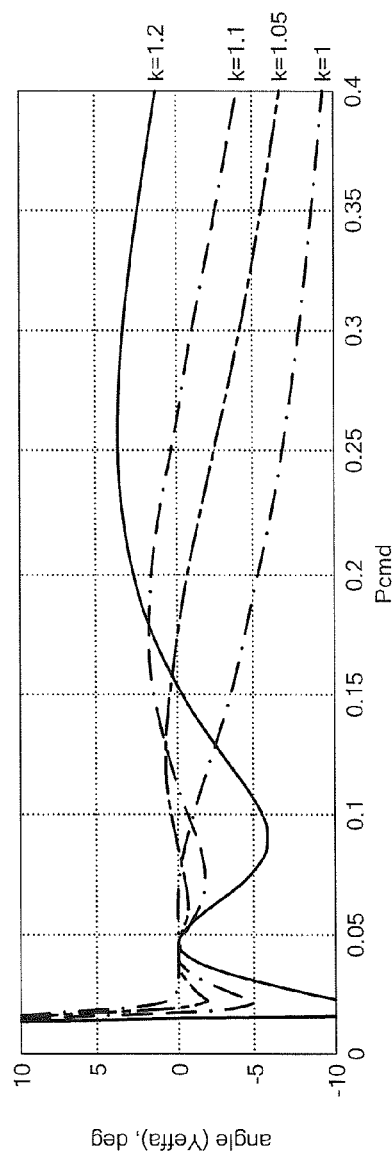

FIG. 15A

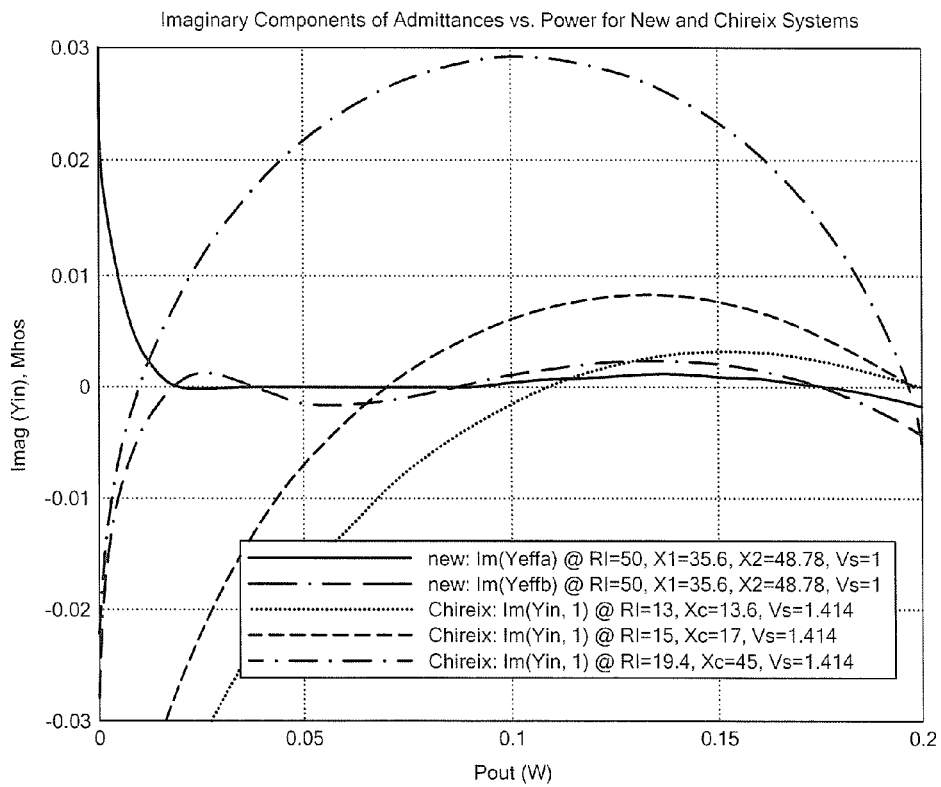

FIG. 16

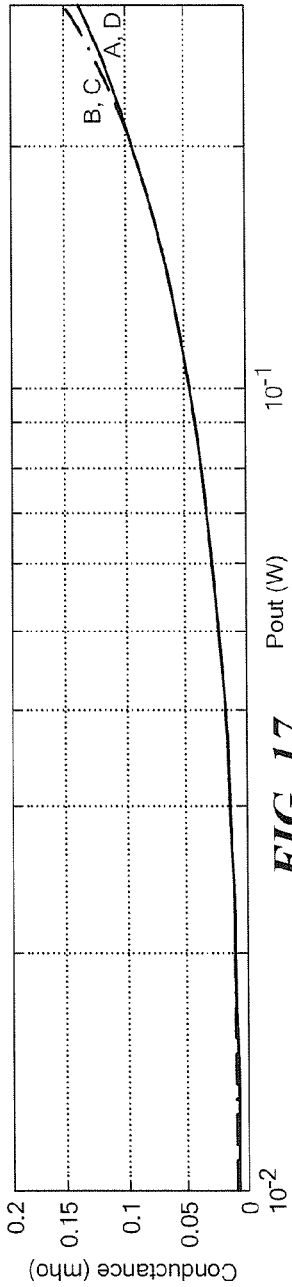

FIG. 17

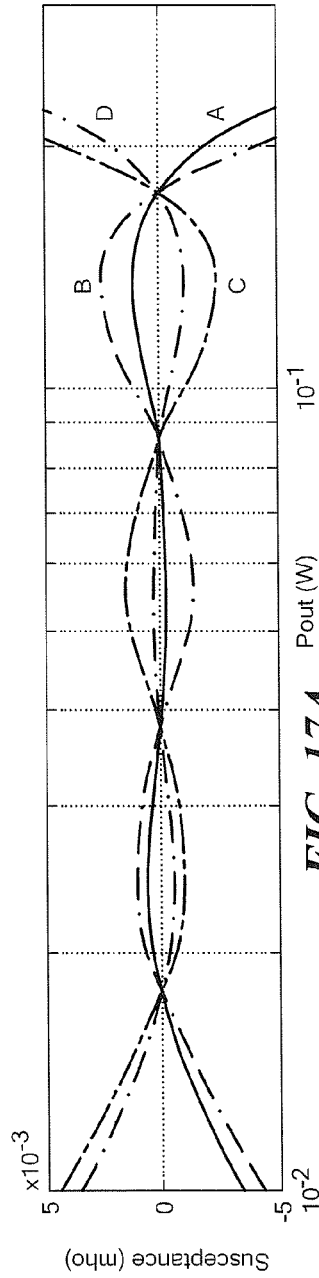

FIG. 17A

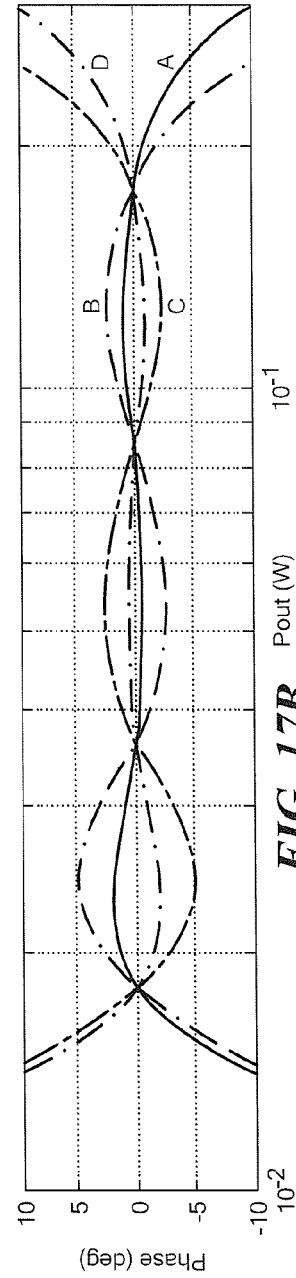

FIG. 17B

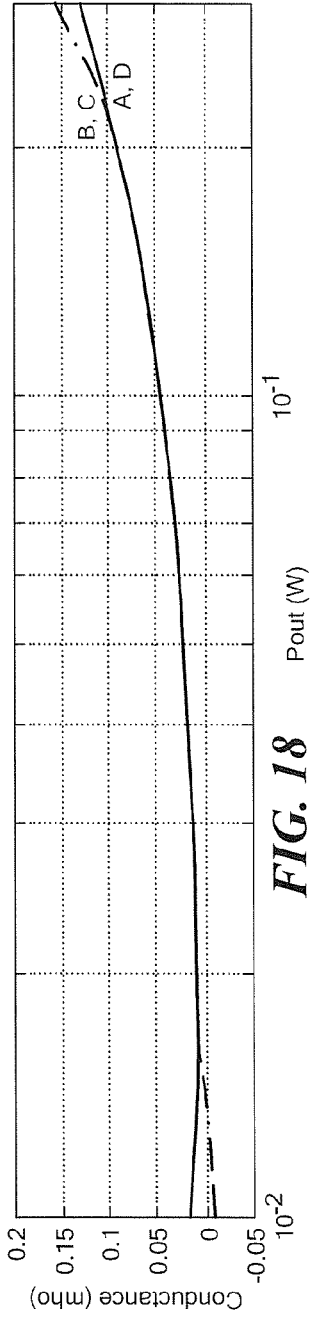

FIG. 18

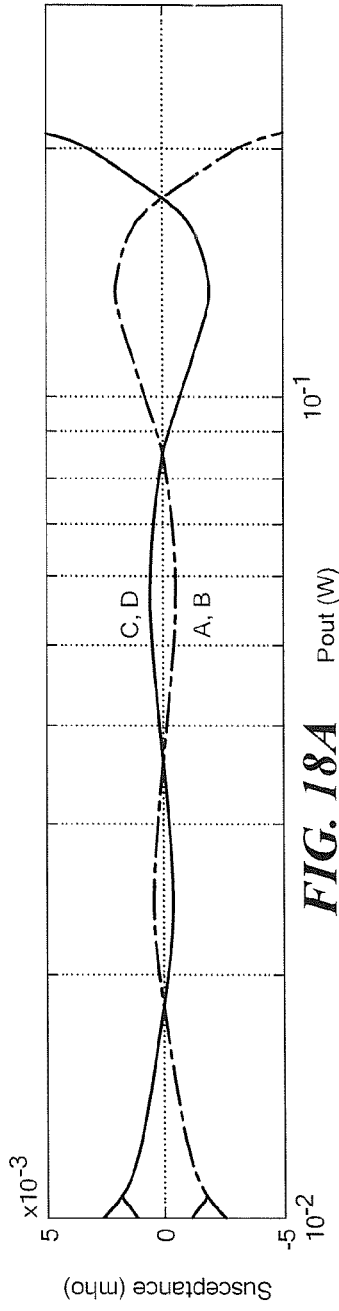

FIG. 18A

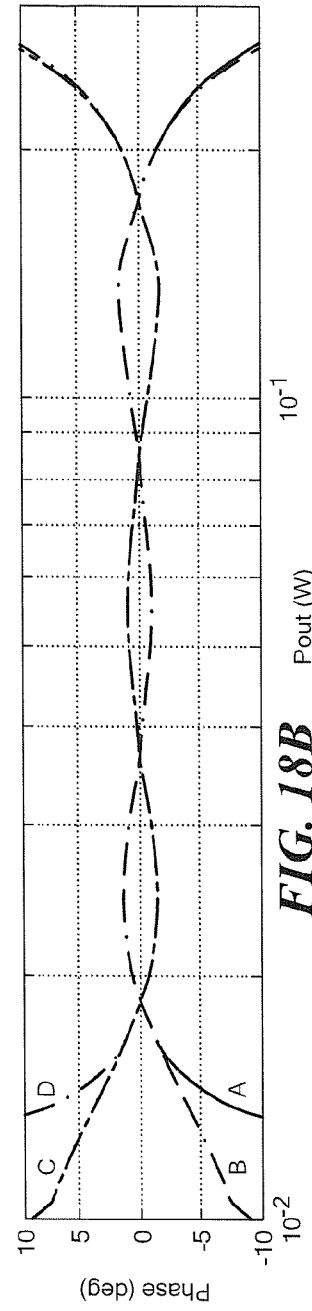

FIG. 18B

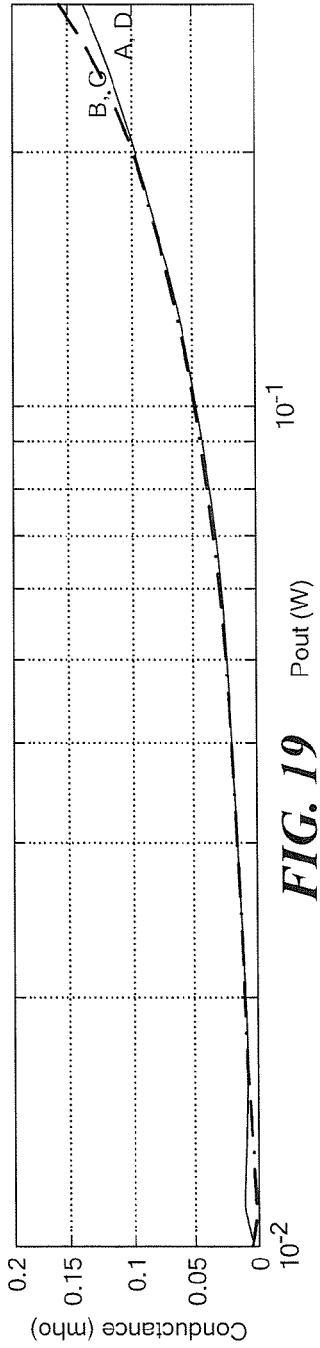

FIG. 19

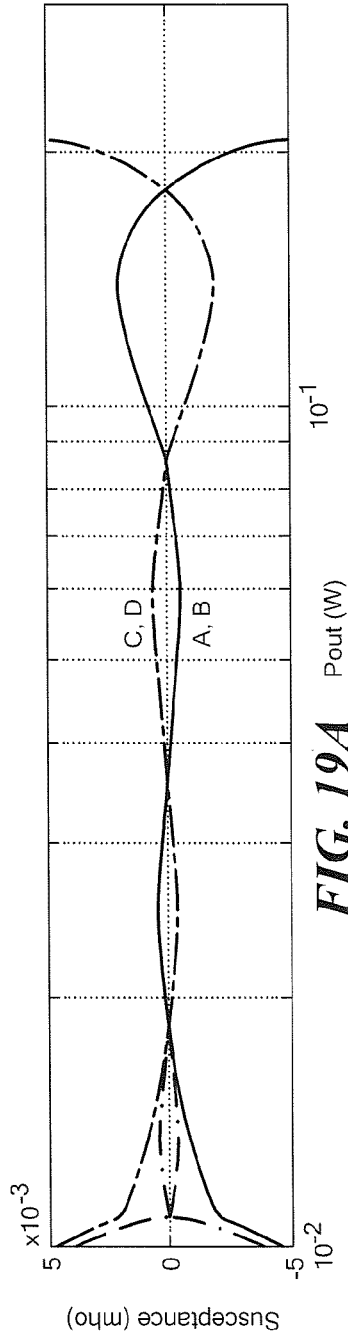

FIG. 19A

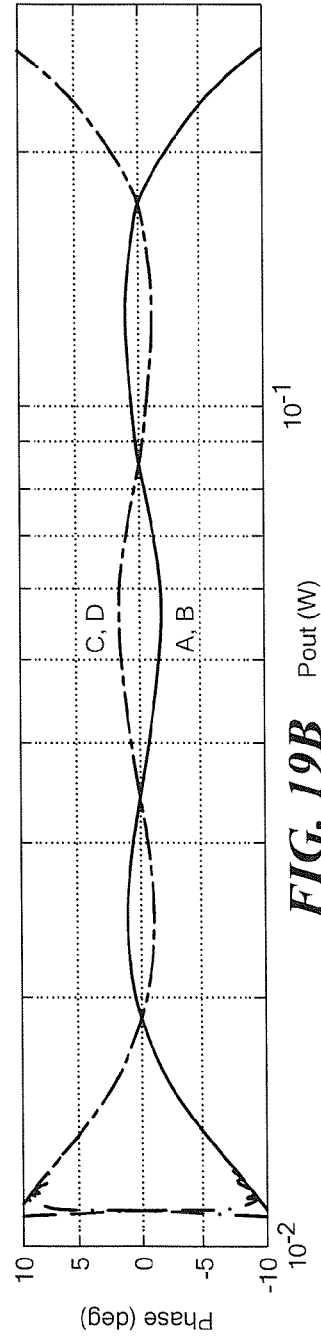

FIG. 19B

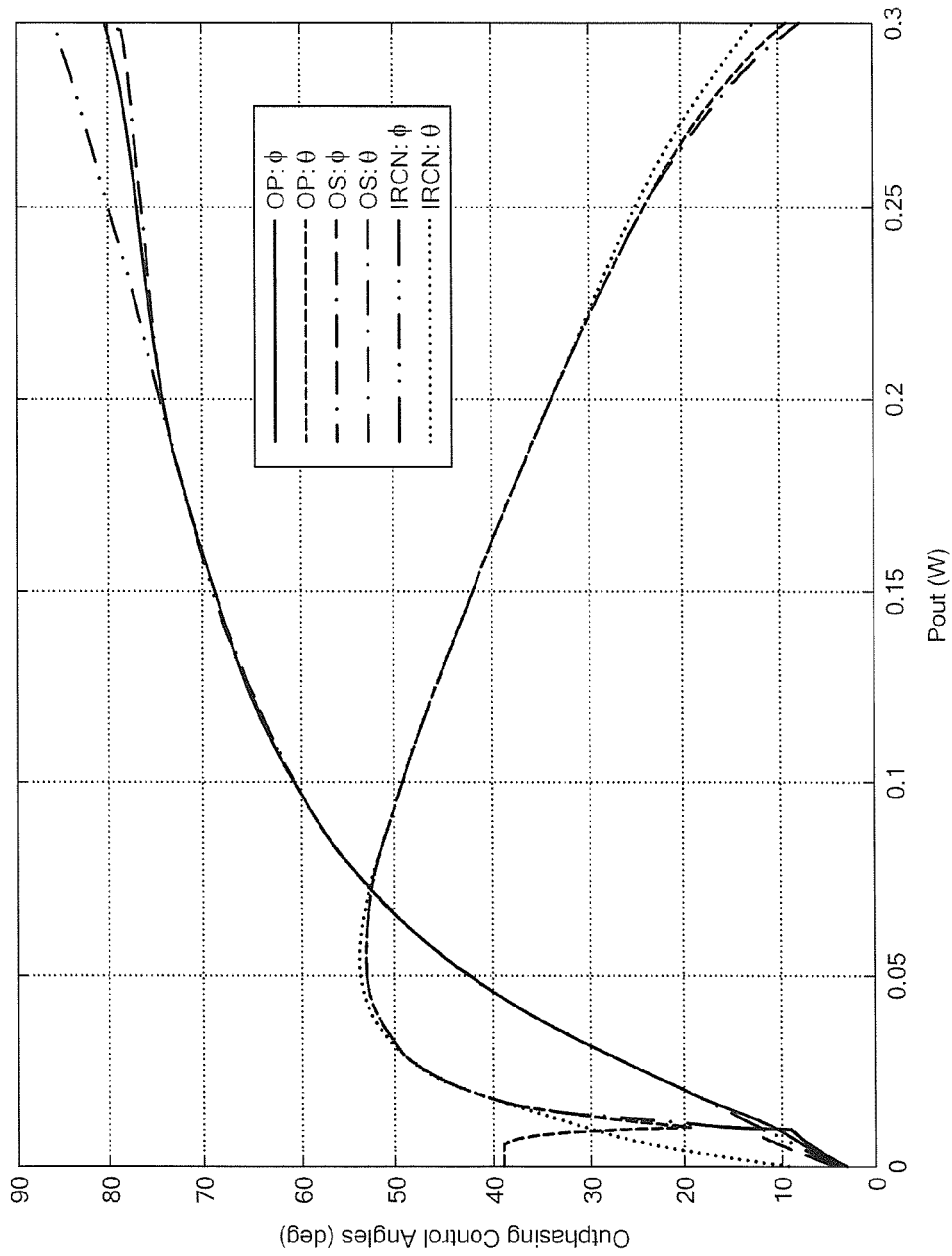

FIG. 20

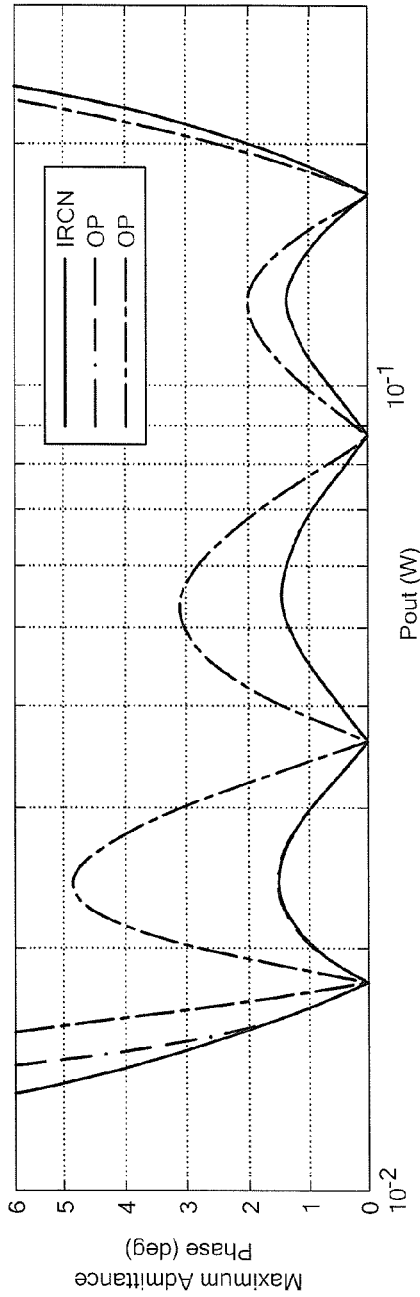

FIG. 21

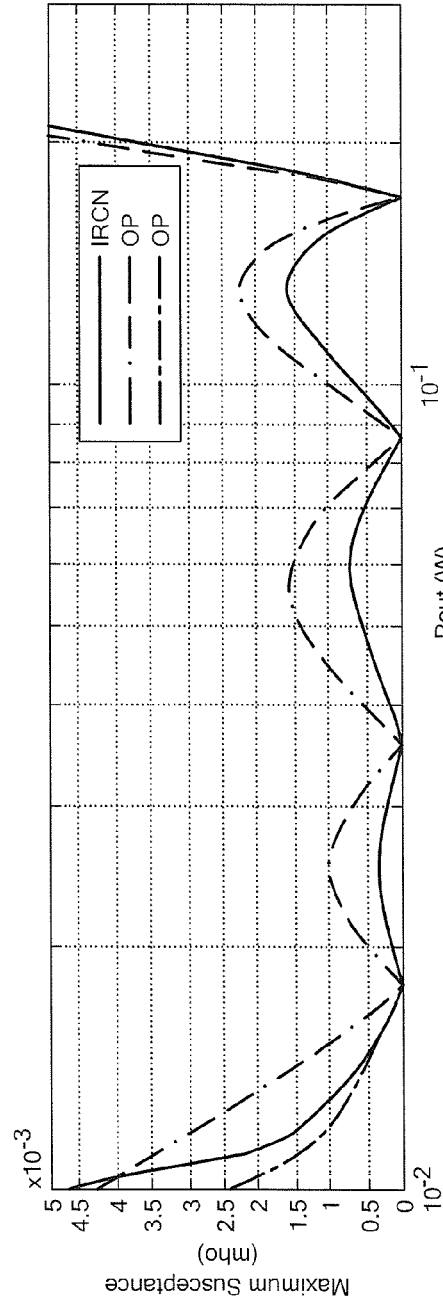

FIG. 21A

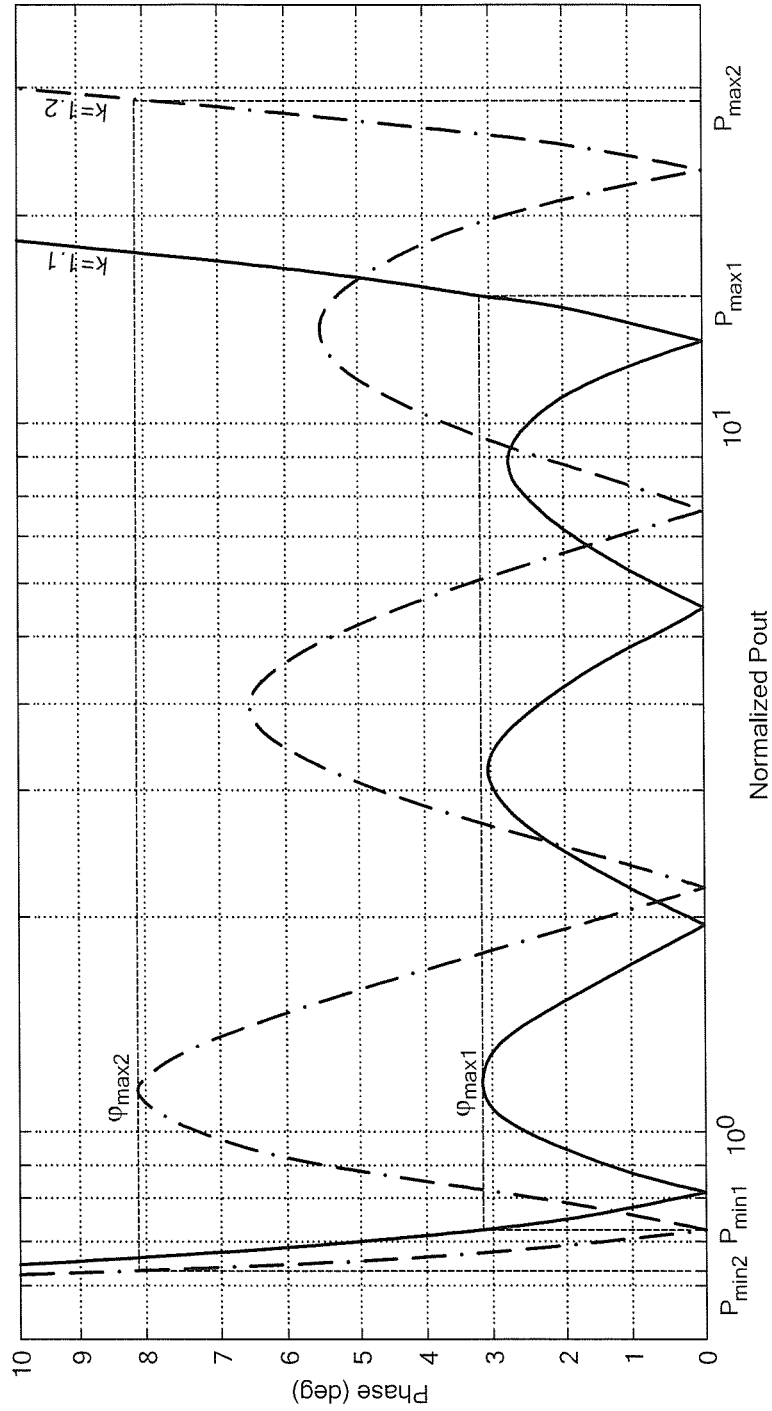

FIG. 22

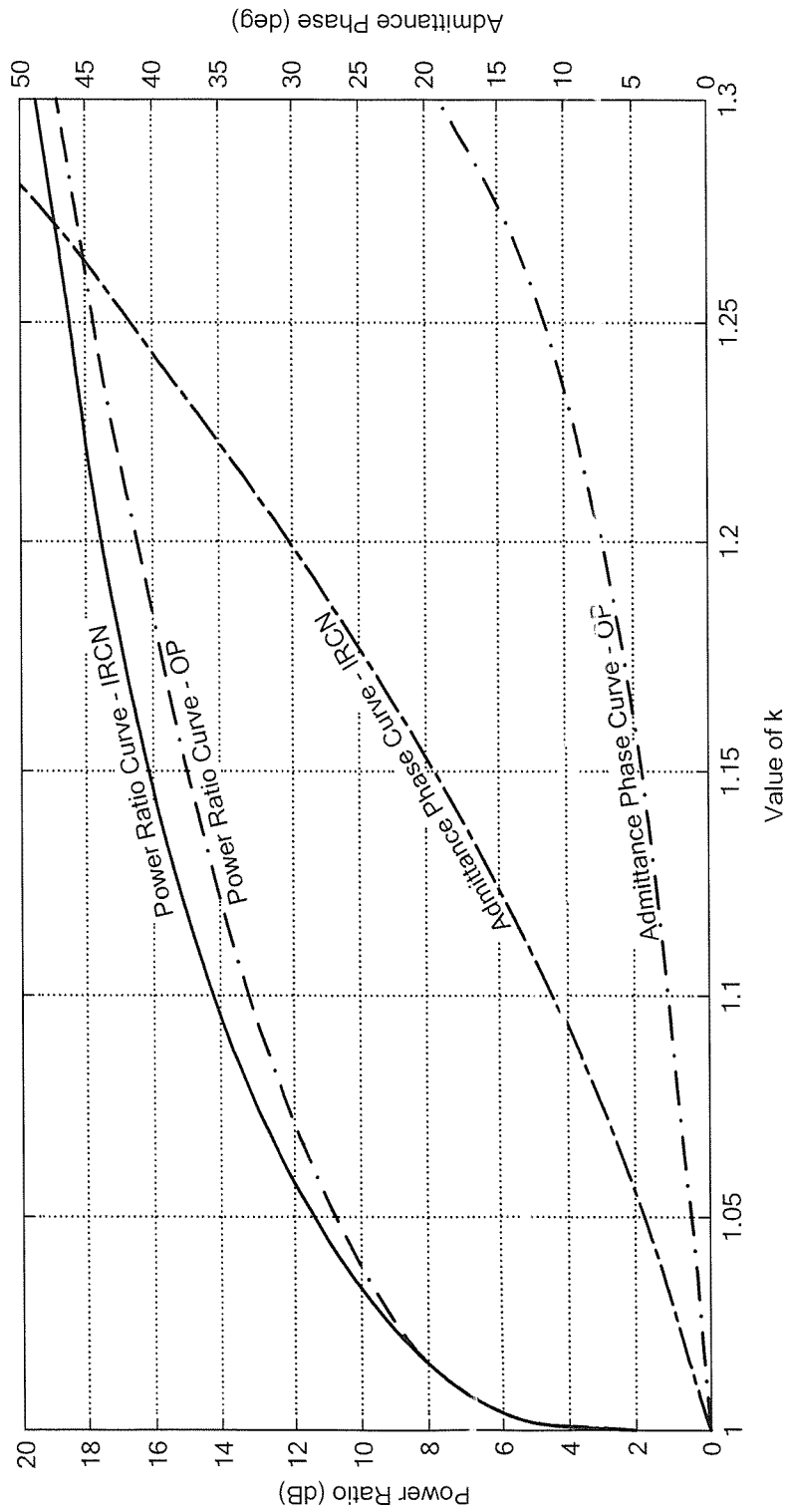

FIG. 23

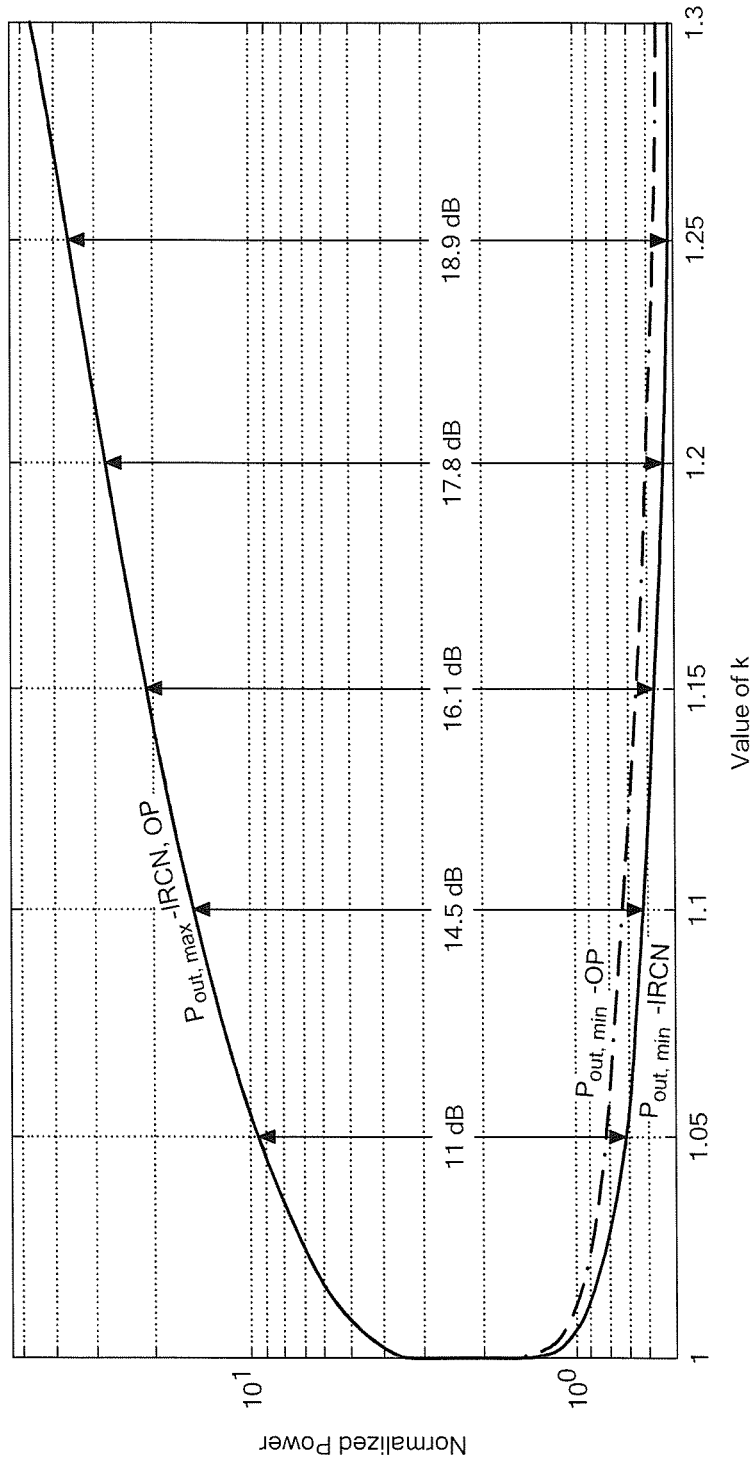

FIG. 24

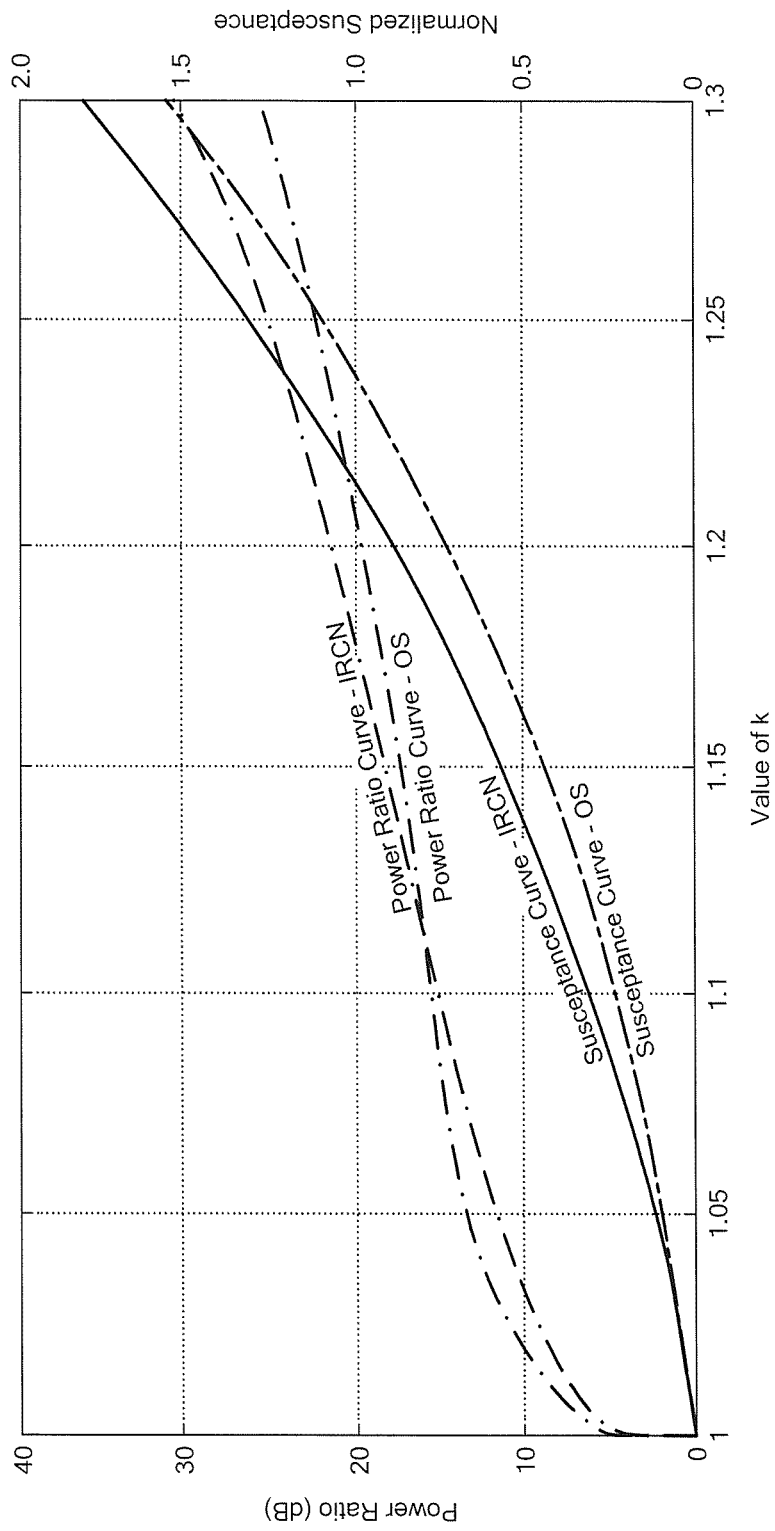

FIG. 25

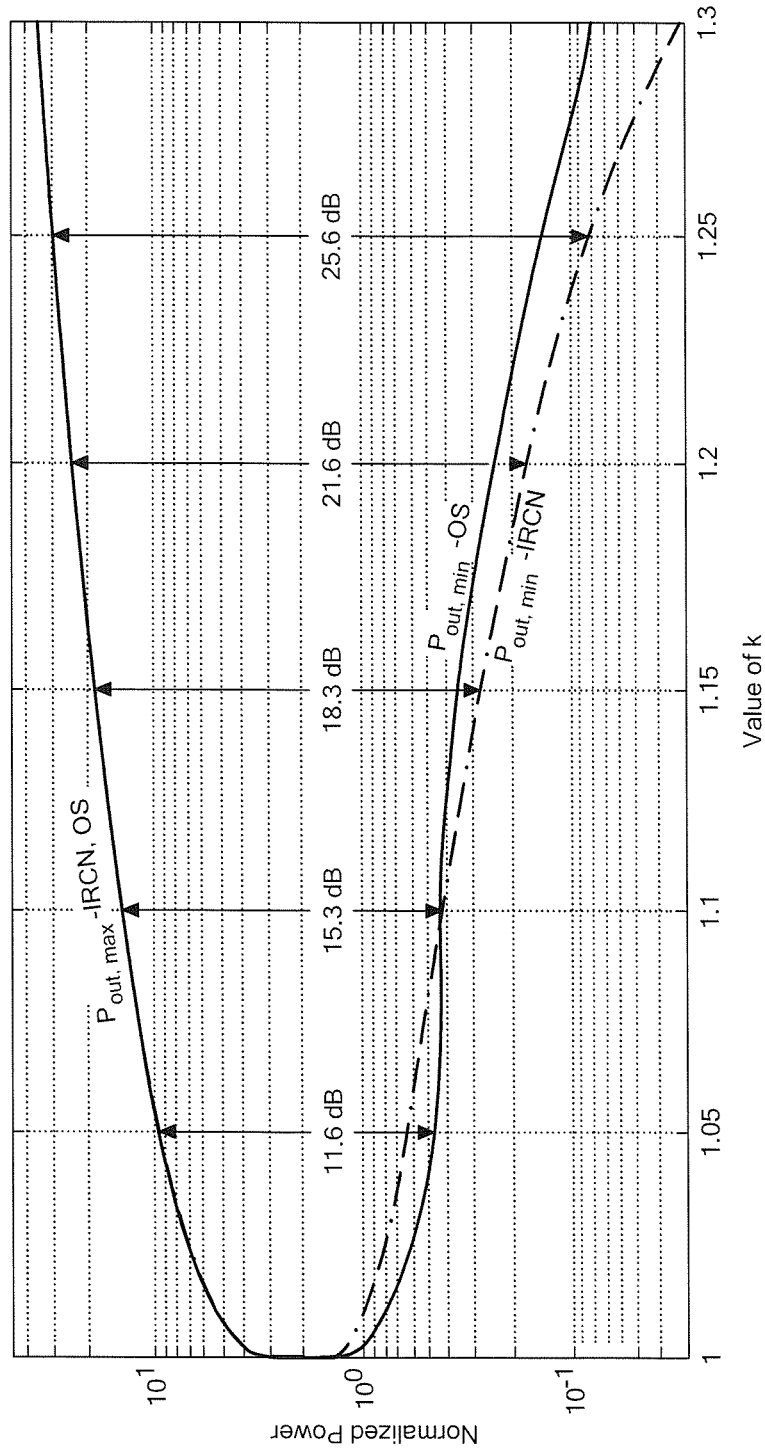

FIG. 26

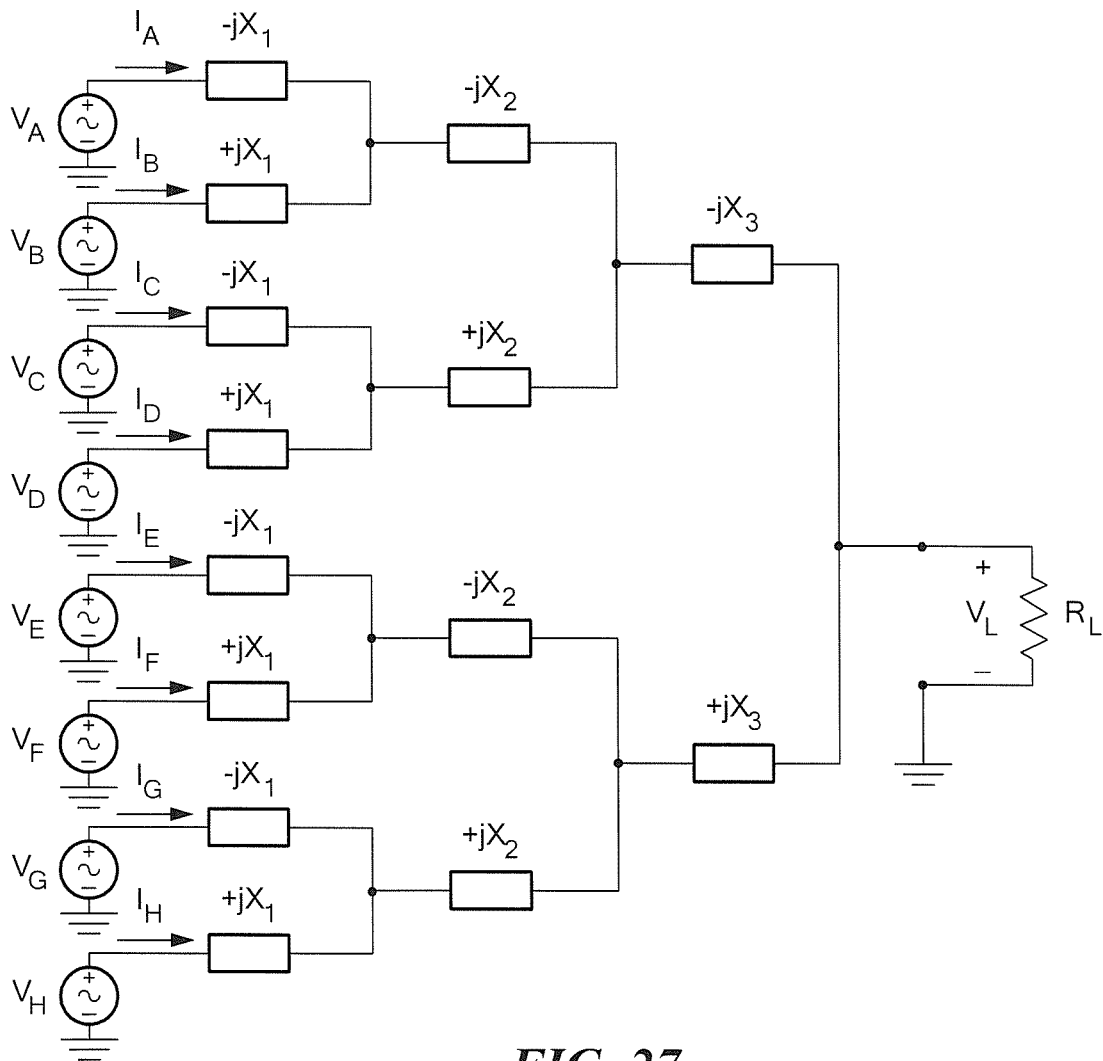

FIG. 27

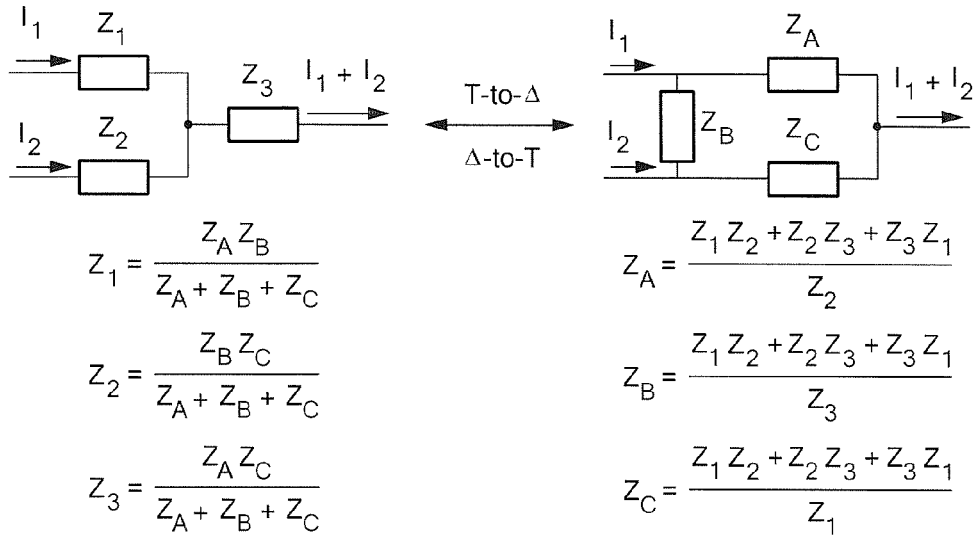

FIG. 28

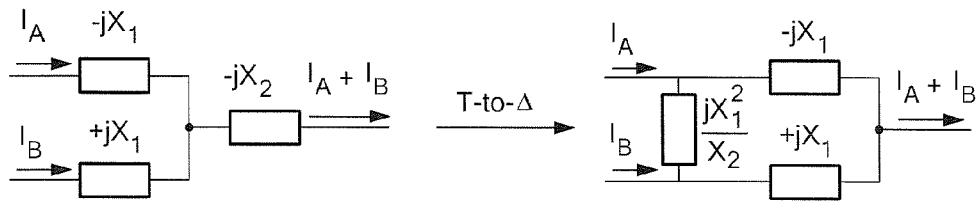

FIG. 29

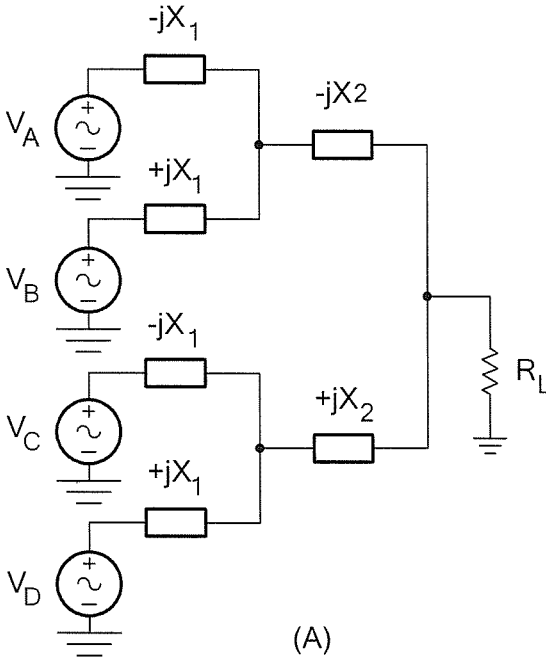

FIG. 30

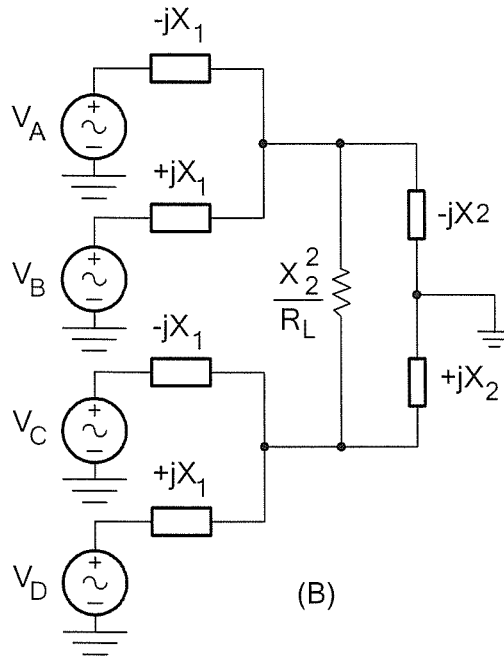

FIG. 30A

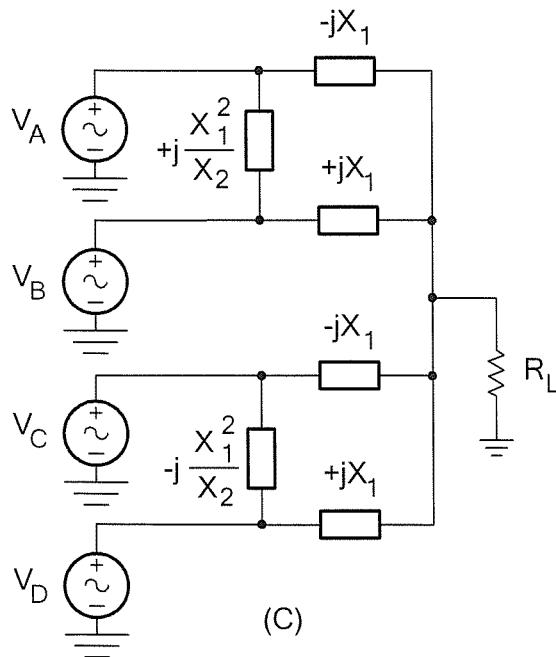

FIG. 30B

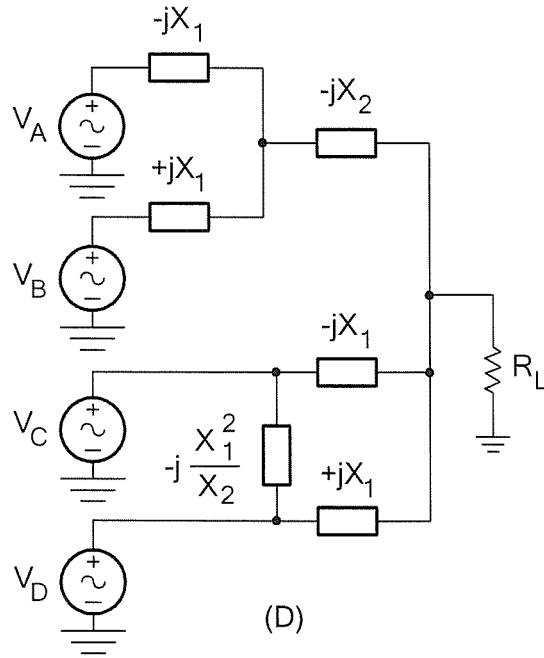

FIG. 30C

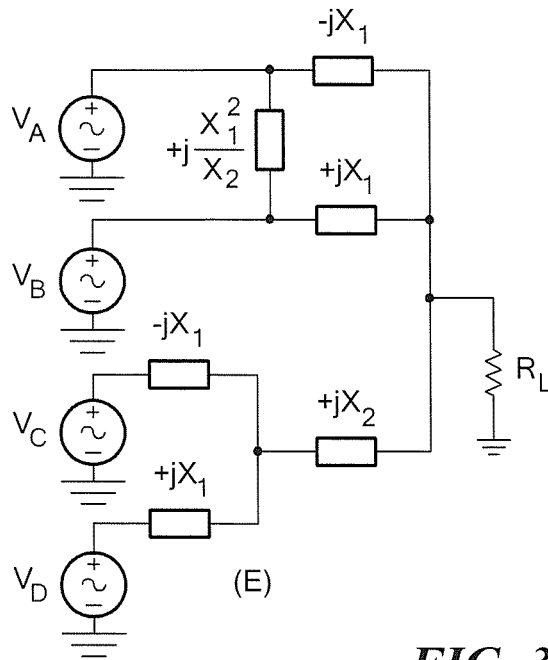

FIG. 30D

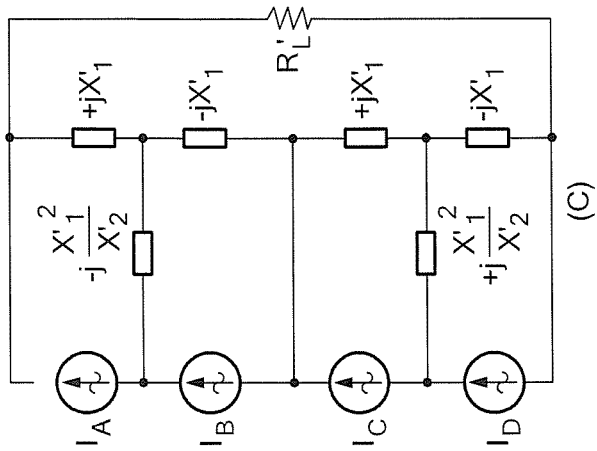

FIG. 31B

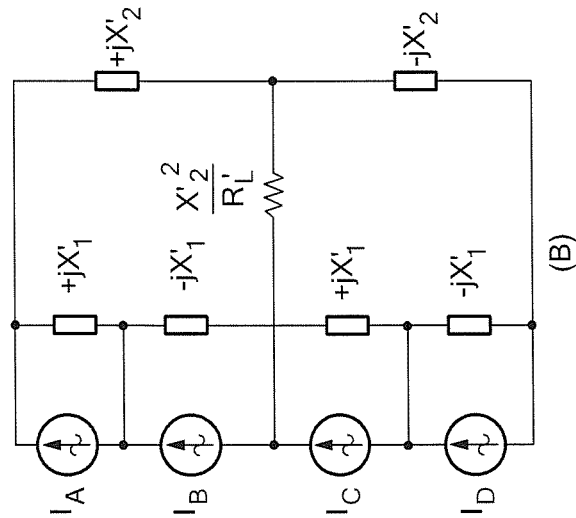

FIG. 31A

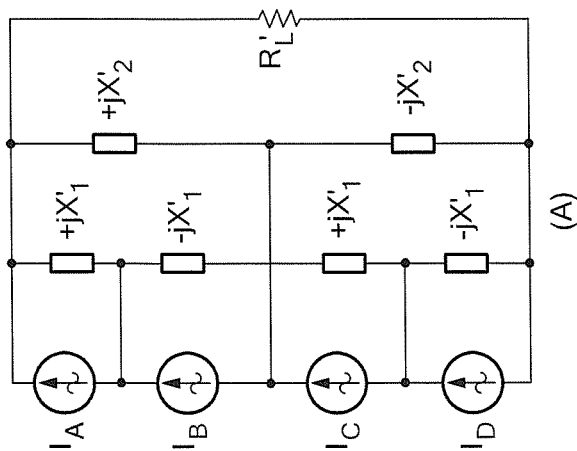

FIG. 31

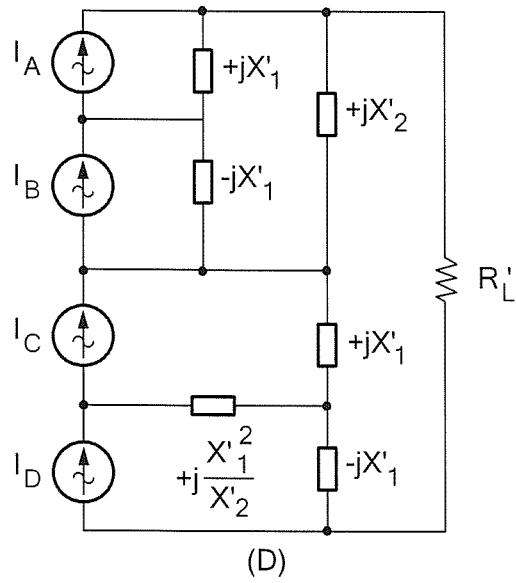

FIG. 31C

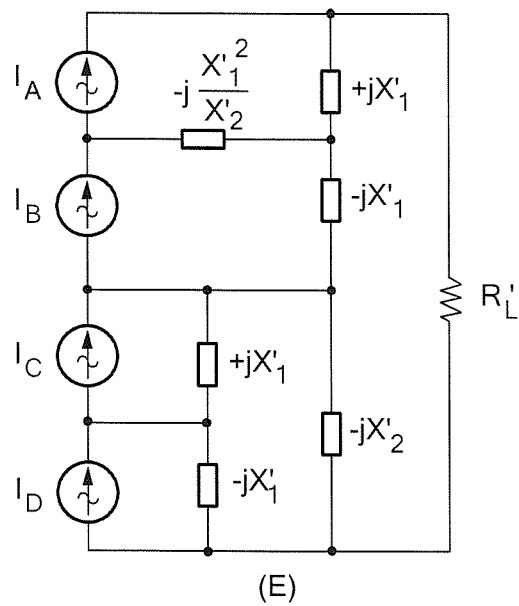

FIG. 31D

1

RADIO-FREQUENCY (RF) AMPLIFIER CIRCUITS AND RELATED TECHNIQUES

CROSS REFERENCE TO RELATED APPLICATIONS

This application claims the benefit under 35 U.S.C. §119 (e) of provisional application No. 61/300,963 filed on Feb. 3, 2010 which application is hereby incorporated herein by reference in its entirety.

STATEMENT REGARDING FEDERALLY SPONSORED RESEARCH

Not Applicable.

FIELD OF THE INVENTION

The concepts described herein relate to radio frequency (RF) amplifiers, and more particularly to power combining and outphasing modulation systems and techniques.

BACKGROUND OF THE INVENTION

As is known in the art, radio-frequency (RF) power amplifiers (PAs) are important in numerous applications, including RF communications, medical imaging, industrial heating and processing, and dc-dc power conversion among many others. PAs are often required to provide linear amplification, which encompasses the ability to dynamically control an RF output power over a wide range. This becomes particularly challenging when wide-bandwidth control of an output signal is required. It is also often desired to maintain high efficiency across a wide range of output power levels, such that high average efficiency can be achieved for highly modulated output waveforms. Simultaneously achieving both of these requirements—wide-bandwidth linear amplification and high average efficiency—has been a longstanding challenge.

As is also known, one concept that has been explored for achieving both linear operation and high efficiency is referred to as outphasing. This technique is also sometimes referred to as “Linear Amplification with Nonlinear Components” or LINC. As shown in FIG. 1, in conventional outphasing, a time-varying input signal $S_{in}(t)$ is decomposed into two constant-amplitude signals $S_1(t)$, $S_2(t)$ which can be summed to provide a desired output signal $S_{out}(t)$. A variable envelope output signal is created as the sum of two constant-envelope signals $S_1(t)$, $S_2(t)$ by outphasing of the two constant envelope signals. Because the two signals $S_1(t)$, $S_2(t)$ are of constant amplitude, they can be synthesized with highly-efficient PAs including partially- and fully-switched-mode designs such as classes D, E, F, E/F and current-mode D, Inverse F, ϕ , etc. These amplifiers can be made highly efficient in part because they needn’t have the capability to provide linear output control. Combining the two constant-amplitude outputs $S_1(t)$, $S_2(t)$ in a power combining network enables the net output amplitude to be controlled via the relative phase of the two constituent components $S_1(t)$, $S_2(t)$.

One important consideration with outphasing is how the power combining is done, particularly because many high-efficiency power amplifiers are highly sensitive to load impedance, and their performance and efficiency can heavily degrade due to interactions between the power amplifiers. As shown in FIG. 2, one conventional approach is to combine the constant-amplitude signals $S_1(t)$, $S_2(t)$ using an isolating combiner. An isolating combiner provides a constant (resistive) loading impedance to each PA independent of the out-

2

phasing angle, eliminating any interactions. A consequence of this, however, is that each PA operates at a constant output power level. Power that is not delivered to the output must instead be delivered elsewhere, usually to an “isolation” resistor R which dissipates power in the form of heat. Thus, a portion of the total constant output power from the PAs is delivered to the output (at the sum port of the combiner); the remainder is delivered to the difference port and is lost as heat in the isolation resistor. This leads to a rapid degradation of efficiency as output power is decreased, diminishing the attractiveness of this approach. This problem can be partially offset by recovering power not delivered to the output through a rectifier. Thus, in some implementations, power not delivered to the output is instead recovered back to the dc supply via a rectifier.

Referring now to FIG. 3, a different conventional approach is to use a lossless combiner, such as a Chireix combiner or related methods. (By “lossless” we mean a combiner including only reactive components or energy storage components such that ideally there would be no loss, while recognizing that all real components have some degree of loss. We also refer to a “lossless” combiner as a reactive combiner.) Benefits of the Chireix combining technique, which is non-isolating, include the fact that the combiner is ideally lossless, and that the real components of the effective load admittances seen by the individual power amplifiers vary with outphasing (and power delivery) such that power amplifier conduction losses can be reduced as output power reduces. However, the reactive portions of the effective load admittances ($Y_{m,1}$, $Y_{m,2}$) are only zero at two outphasing angles, and become large outside of a limited power range (see the example plots in FIG. 3). This limits efficiency, due both to loss associated with added reactive currents and to degradation of power amplifier performance with (variable) reactive loading. Stated differently, the reactive impedances $+jX_c$, $-jX_c$ of the combiner compensate for the effective reactive loading on the PAs due to interactions between them. However, because the effective reactive loading due to PA interactions depends upon operating point (outphasing angle), compensation is imperfect over most of the operating range. This can thus lead to loss of efficiency and PA degradation when operating over wide ranges.

Accordingly, the above-described challenges with power combining are among the principal reasons that outphasing is not a more dominant architecture in RF applications.

It would, therefore, be desirable to provide a power combining and outphasing modulation system for use in RF applications that overcomes the loss and reactive loading problems of previous outphasing approaches by providing ideally lossless power combining, along with substantially resistive loading of the individual power amplifiers over a very wide output power range, enabling high average efficiency to be achieved even for large peak-to-average power ratios (PAPR).

SUMMARY OF THE INVENTION

In accordance with the present concepts, systems and techniques described herein, a power combining and outphasing system includes a reactive combiner having four or more input ports and an output port and four or more power amplifiers, each of the four or more power amplifiers having an input and an output, with the output of each power amplifier coupled to a respective one of the four or more input ports of the reactive combiner. It should be appreciated that as used herein, the term “reactive combiner” refers to a combiner provided from circuit components that store or transfer energy, including inductors, capacitors, transformers, and

transmission lines among other components. These components may be modeled with circuit elements having reactive impedance characteristics in a radio frequency (RF) range of interest (so called reactive components) or as energy storage components or energy transfer components such that ideally there would be no loss. It is, of course, recognized that all real components have some degree of loss. Thus, such reactive combiners are also sometimes referred to as a “lossless combiners”. It should also be appreciated that circuit components having reactive impedance characteristics in a radio frequency (RF) range of interest may be implemented as inductors, capacitors, transformers, and transmission lines which may be provided as either lumped element circuit components or as distributed element circuit components such as can be implemented through RF transmission lines.

With this particular arrangement, a power combining and outphasing system which provides ideally lossless power combining along with substantially resistive loading of the individual power amplifiers over a very wide output power range is provided. It should be appreciated that resistive loading of the individual power amplifiers over a very wide output power range enables high average efficiency to be achieved even for large peak-to-average power ratios (PAPR). Thus, the power combining and outphasing system described herein overcomes the loss and reactive loading problems of prior art outphasing systems and approaches. It should be appreciated that it has been discovered that to achieve superior performance, it is necessary to consider the characteristics (e.g. reactance values) each of each portion of the combiner. It should also be appreciated that to achieve the highest performance, the values from each portion of the combiner are utilized in control laws used to perform outphasing. It should, of course, be appreciated that in some embodiments, the reactive combiner described herein may be viewed as being comprised as a number of “separate” reactive combiners that are interconnected in a cascade and interact with one another, but this need not be so (as can be seen from many of the permuted implementations described herein in which “separate” combiners cannot be identified). When seeking to view the combiner as an interconnected cascade of “separate” combiners (when this can be done), it is important to recognize that the “separate” combiners interact with one another in a way that is important to the effective admittance characteristics seen at the combiner inputs, and cannot be viewed as a number of separate combiners that do not interact (as would be true in a system incorporating isolating combiner(s), for example). Significantly, however, regardless of whether the reactive combiner described herein is viewed as a single combiner or as being comprised from a plurality of “separate” combiners that interact with one another, the performance of the reactive combiner depends upon all sections of the combiner from the inputs to the output. Consequently, to achieve high performance, the reactance values (and similar characteristics) of all elements in the combiner are taken into account in the control strategy of an outphasing system.

In one embodiment, a combiner for four power amplifiers is provided from a plurality of reactive elements with first ones of the reactive elements having a first specified reactance magnitude at an operating frequency and second ones of the reactive elements having a second, different specified reactance magnitude at the operating frequency. In one embodiment, the first ones of the reactive elements have a first specified reactance magnitude at the operating frequency and the second ones of the reactive elements having a second, different specified reactance magnitude at the operating frequency. The first and second reactance magnitudes are selected such that, with the appropriate control angles for the amplifiers, the

combiner provides substantially resistive loading of the individual power amplifiers over a very wide output power range. Systems maintaining high efficiency over 5:1, 10:1, 20:1 and even beyond 50:1 power ratios can be constructed with this approach. It should thus be appreciated that the concepts, circuits and techniques described herein finds application in a wide variety of different systems including, but not limited to, RF communications, medical imaging, industrial heating and processing, and dc-dc power converters and other switched-mode power converter systems.

In accordance with a further aspect of the present concepts, systems and techniques described herein, a power combining and outphasing modulation system includes a combiner provided from a plurality of stages of reactive elements and having four or more input ports and an output port and four or more power amplifiers, each of the four or more power amplifiers having an input and an output, with the output of each power amplifier coupled to a respective one of the four or more input ports of the combiner. The combiner has one or more reactive elements each having a specified reactance at an operating frequency or a specified range of reactances over an operating frequency range. In some embodiments for N inputs to the combiner there will be $2N-2$ reactances (e.g., a combiner having four input ports, includes six reactive elements). In some, but not all, embodiments the combiner is constructed as multiple stages, each one of the reactive elements in a given stage has a first specified reactance magnitude at the operating frequency. In some embodiments, the reactive elements within a stage have the same reactance magnitude at the operating frequency while reactive elements in different stages have a possibly different specified reactance magnitude at the operating frequency.

In accordance with a further aspect of the present concepts, systems and techniques described herein, a power combining and outphasing system includes a combiner having four or more input ports and an output port; having a plurality of reactive elements with first ones of the reactive elements having a first specified reactance magnitude at an operating frequency and second ones of the reactive elements having a second specified reactance magnitude at the operating frequency; and four or more power amplifiers, each of the four or more power amplifiers having an input and an output, with the output of each power amplifier coupled to a respective one of the four or more input ports of the combiner. In preferred embodiments, the first specified reactance magnitude is different than the second specified reactance magnitude.

In accordance with a still further aspect of the present concepts, systems and techniques described herein, a system for delivering and controlling power from a number N greater than two radio-frequency (RF) power sources to a single output, the system includes N RF power sources each having an output port, each of the N RF power sources configured to deliver RF power to its output port, a lossless power combiner, the lossless power combiner comprising N input ports, $2N-2$ reactive branches having specified reactance values, and an output port configured to receive RF power, wherein each of the output ports of the N RF power sources are coupled to a corresponding one of the input ports of the lossless power combiner, and RF power delivered to the output port of the power combiner is controlled by adjusting the phases of the N radio-frequency power sources as a function of the reactance values of the $2N-2$ reactive branches.

In one embodiment, in response to adjusting the phases of the N radio-frequency power sources as a function of the reactance values of the $2N-2$ reactive branches, an effective loading impedance presented to each of the N RF power

5

sources at the input ports of the power combiner are purely resistive at N output power levels.

In one embodiment, the largest magnitudes of the susceptible portion of the effective loading admittances seen by the N RF power sources are smaller than is achievable with any combination of Chireix and lossless in-phase power combining over a range of RF output power levels bounded by highest and lowest RF output power levels where the purely resistive loading of the radio-frequency power sources occurs.

In accordance with a still further aspect of the present concepts, systems and techniques described herein, a radio-frequency (RF) system includes four or more RF signal sources each of the four or more RF signal sources having an output port; and a reactive power combiner having four or more input ports and an output port, each reactive power combiner input port coupled to a corresponding one of the RF signal source output ports and wherein the reactive power combiner includes $2N-2$ reactive branches, each of the $2N-2$ reactive branches having a predetermined reactance value, wherein the power delivered to the reactive power combiner output port is controlled by adjusting a phase characteristic of each of the four or more RF signal sources as a function of the reactance values of the $2N-2$ reactive branches.

In one embodiment, each of the four or more RF signal sources comprise an RF amplifier having an RF input port and an RF output port coupled to a respective one of the input ports of the reactive power combiner.

In one embodiment, the number of input ports of the reactive power combiner matches the number of RF signal sources.

In one embodiment, each of the $2N-2$ reactive branches of the power combiner comprises at least one reactive element with first ones of the reactive elements having a first specified reactance magnitude at an operating frequency and second ones of the reactive elements have a second, different specified reactance magnitude at the operating frequency.

In one embodiment, each of the $2N-2$ reactive branches of the power combiner comprises at least one reactive element with first ones of the reactive elements having a first specified reactance at an operating frequency and second ones of the reactive elements have a second, opposite specified reactance at the operating frequency.

In one embodiment, the reactance values of each of the $2N-2$ reactive branches of the reactive power combiner are selected such that the reactive power combiner provides dominantly resistive loading of each of the RF signal sources coupled to the reactive power combiner input ports over a range of output power.

In one embodiment, the combination of the four or more RF signal sources and the reactive power combiner form a power amplifier circuit and wherein the RF system comprises a plurality of such power amplifier circuits.

In one embodiment, the RF system includes a plurality of power amplifier circuits and an isolating combiner coupled between each pair of power amplifier circuits such that outphasing groups of the power amplifier circuits can be achieved.

In one embodiment, the RF system further includes a drain modulation circuit coupled to each of the power amplifier circuits. In one embodiment, the drain modulation circuit includes one or more of: an adaptive bias circuit, a polar modulation circuit, a discrete drain switching circuit. In one embodiment, the drain modulation circuit operates in accordance with an asymmetric multilevel outphasing technique.

6

In one embodiment, the drain modulation circuit implements gate-width switching of the power amplifiers to reduce losses at small output powers.

In one embodiment, the reactive power combiner comprises at least one of: one or more distributed circuit elements; one or more lumped circuit elements; or a combination of distributed and lumped circuit elements.

In some embodiments, the relative phases of each of the four or more RF signal sources are controlled such that an effective immittance phase amplitude seen at any of the power combiner inputs is limited as output power varies over a specified ratio with the phase amplitudes satisfying at least one of: less than 1 degree over a factor of 5 in power; less than 5 degrees over a factor of ten in power; less than ten degrees over a factor of twenty in power; and less than thirty degrees over a factor of fifty in power. In some embodiments these represent the worst case effective immittance phase amplitude.

In some embodiments, the relative phases of each of the four or more RF signal sources are controlled such that an effective immittance phase amplitude seen at any of the power combiner inputs is limited as output power varies over a specified ratio with the phase amplitudes satisfying at least one of: less than two degrees over a factor of ten in power; five degrees over a factor of twenty in power; and fifteen degrees over a factor of fifty in power. In some embodiments these represent the worst case effective immittance phase amplitude.

In some embodiments the relative phases of the RF signal sources are adjusted as a continuous function of the commanded output power or voltage amplitude.

In accordance with a further aspect of the concepts described herein, a radio-frequency (RF) system includes N greater than or equal to eight RF signal sources each of the at least N RF signal sources having an output port; and a reactive power combiner having at least eight input ports and an output port, each reactive power combiner input port coupled to a corresponding one of the RF signal source output ports and wherein the reactive power combiner includes $2N-2$ reactive branches, each of the $2N-2$ reactive branches having a predetermined reactance value, wherein the power delivered to the reactive power combiner output port is controlled by adjusting a phase characteristic of each of the N RF signal sources as a function of the reactance values of the $2N-2$ reactive branches.

In one embodiment, the relative phases of each of the N RF signal sources are controlled such that the worst case effective immittance phase amplitude seen at any of the N power combiner inputs is limited as output power varies over a specified ratio, the worst-case phase amplitudes satisfying at least one of: less than 1 degree over a factor of 5 in power; less than 5 degrees over a factor of ten in power; less than 10 degrees over a factor of 20 in power; and less than 30 degrees over a factor of 50 in power.

In one embodiment, the relative phases of each of eight RF signal sources are controlled such that the effective immittance phase amplitude seen at any of eight power combiner inputs is limited as output power varies over a specified ratio, the phase amplitudes satisfying at least one of: 1 degree for 20:1 power; 2 degrees for 50:1 power; and 5 degrees for 100:1 power. In one embodiment, these values represent worst case values (i.e. the worst case effective immittance phase amplitude seen at any of the eight power combiner inputs is limited as output power varies over a specified ratio and the worst case phase amplitudes satisfy at least one of: 1 degree for 20:1 power; 2 degrees for 50:1 power; and 5 degrees for 100:1 power).

In accordance with a still further aspect of the concepts described herein, a power amplifier system includes N power amplifiers where $N=2^M$ and M is an integer greater than one, each of the N power amplifiers having an input port and an output port, a reactive combiner having an output port and N input ports, each of the N input ports of the reactive combiner coupled to an output of a respective one of the N power amplifiers, the reactive combiner including a plurality of reactive branches with each of the reactive branches having an impedance characteristic corresponding to one of M specified impedance levels; and a control system configured to adjust an amplitude of a voltage at the output of the combiner by controlling the relative phase of the N power amplifiers as a function of all of the M specified impedance levels.

In one embodiment the effective susceptances at the N inputs of the combiner are zero for at least N output voltage amplitudes.

In one embodiment for the range of output voltage amplitudes between those for which the effective susceptances are zero, the effective susceptance amplitude at each of the combiner inputs is substantially the same.

In one embodiment for the range of output voltage amplitudes between those for which the effective susceptances are zero, the effective immittance phase amplitude at each of the combiner inputs is substantially the same.

In one embodiment the M specified impedance levels are selected as a function of a single design parameter and a specified load resistance.

In one embodiment there are $2N-2$ of the reactive branches with 2^m branches having an impedance magnitude at the m^{th} . . . M impedance level (i.e. there are M impedance levels, and a variable m that takes on values from 1 to M. $m=[1, 2, 3 \dots M]$) There are $2=2^1$ reactances at the $m=1$ impedance level, there are $4=2^2$ reactances at the $m=2$ impedance level, and so forth up to 2^M reactances at the M^{th} impedance level; this corresponds to the combiners of FIGS. 4 and 27 as well as 30, 30A, 30B, 31, 31A, 31B).

In one embodiment the power combiner can be transformed into a network including a binary tree of reactances having complementary reactances at each bifurcation in the tree through application of zero or more of: T-Delta transformations; and topological duality transformations.

In one embodiment the control system is further configured to adjust an amplitude of a voltage at the output of the combiner by controlling one or more of: the power supply voltages of the N power amplifiers; and the RF input drive amplitudes of the N power amplifiers.

BRIEF DESCRIPTION OF THE DRAWINGS

The foregoing features of this invention, as well as the invention itself, may be more fully understood from the following description of the drawings in which:

FIG. 1 is a block diagram of a conventional outphasing architecture (also known as a linear amplification with non-linear components (LLAC) architecture);

FIG. 1A is a phasor diagram showing a relationship among the phase voltages for the conventional outphasing architecture shown in FIG. 1;

FIG. 2 is a block diagram of a conventional outphasing architecture implemented with an isolating combiner;

FIG. 3 is a block diagram of a conventional outphasing system implemented with a Chireix combiner;

FIG. 3A is a plot of imaginary vs. real components of the effective admittances for the outphasing system of FIG. 3;

FIG. 4 is a block diagram of an outphasing system which includes a combiner having four input ports and an output port with a power amplifier (PA) coupled to each input port;

FIG. 4A is a block diagram of a power combiner system comprising: (a) power combiner, (b) four power amplifiers (PA A-PA D), and (c) amplitude/phase control unit responsible for adjusting the amplitudes (A_A - A_D) and phases (Φ_A - Φ_D) of the input signals to the respective PAs based on user command and feedback data.

FIG. 4B is a block diagram of a power combiner system comprising: (a) power combiner, (b) four power amplifiers (PA A-PA D), (c) power supply control unit responsible for adjusting the supply voltages (V_{S1} - V_{S4}) of the respective PAs, and (d) amplitude/phase control unit responsible for adjusting the amplitudes (A_A - A_D) and phases (Φ_A - Φ_D) of the input signals to the respective PAs based on user command and feedback data.

FIG. 5 is a phasor diagram showing the relationship among the phase voltages;

FIG. 6 is a plot showing outphasing control angles vs. commanded output power for an approximate inverse resistance compression network (AIRCN) outphasing control method;

FIG. 7 is a plot of actual output power vs. commanded power for an example system comprising a four-port combiner and having $V_s=1$ V, $R_L=50\Omega$, $X_2=48.78\Omega$ and $X_1=35.60\Omega$ using the AIRCN outphasing control method;

FIG. 8 is a plot of real components of the effective input admittances at the input ports of a four input port power combiner plotted as a function of the power command P_{cmd} for the example $R_L=50\Omega$, $X_2=48.78\Omega$ and $X_1=35.60\Omega$ over the commanded power range of [0.01,0.25] W using the AIRCN outphasing control method;

FIG. 8A is a plot of imaginary components of the effective input admittances at the four power combiner input ports plotted as a function of the power command P_{cmd} for the example $R_L=50\Omega$, $X_2=48.78\Omega$ and $X_1=35.60\Omega$ over the commanded power range of [0.01,0.25] W AIRCN outphasing control method;

FIG. 9 is a plot of magnitude of the effective admittances at the four power combiner input ports, plotted as a function of the power command P_{cmd} for the example $R_L=50\Omega$, $X_2=48.78\Omega$ and $X_1=35.60\Omega$ over the commanded power range of [0.01,0.25] W using the AIRCN outphasing control method;

FIG. 9A is a plot of phase of the effective admittances at the four power combiner input ports, plotted as a function of the power command P_{cmd} for the example $R_L=50\Omega$, $X_2=48.78\Omega$ and $X_1=35.60\Omega$ over the commanded power range of [0.01, 0.25] W using the AIRCN outphasing control method;

FIG. 10 is a plot of real components of the effective admittance $Y_{eff,c}$ for the example $V_s=1$ V, $R_L=50\Omega$, $f=10$ MHz, $X_2=48.78\Omega$ and $X_1=35.60\Omega$ using the AIRCN outphasing control method;

FIG. 10A is a plot of imaginary components of the effective admittance $Y_{eff,c}$ for the example $V_s=1$ V, $R_L=50\Omega$, $f=10$ MHz, $X_2=48.78\Omega$ and $X_1=35.60\Omega$ using the AIRCN outphasing control method;

FIG. 11 is a plot of percentage power loss in the combiner (100-fl) vs. commanded input power for the example $V_s=1$ V, $R_L=50\Omega$, $f=10$ MHz, $X_2=48.78\Omega$ and $X_1=35.60\Omega$ for component quality factors $Q=100$ using the AIRCN outphasing control method.

FIG. 12 is a block diagram of a resistance compression network (RCN);

FIG. 12A is a plot of input impedance R_{in} as a function of the matched load resistance value R_o for the resistance compression network (RCN) of FIG. 12;

FIG. 13 is a block diagram of a multi-stage resistance compression network based on a cascade of the single-stage RCN network of FIG. 12;

FIG. 14 is a plot of resistive input impedance $R_{in,2}$ as a function of the matched load resistance value R_o for the two-stage compression network of FIG. 13;

FIG. 15 is a plot of a magnitude of the effective admittance $Y_{eff,A}$ in the combiner of FIG. 4 in conjunction with control laws of Equations (10)-(12) for different values of design parameter k ;

FIG. 15A is a plot of an angle of the effective admittance $Y_{eff,A}$ in the combiner of FIG. 4 in conjunction with control laws of Equations (10)-(12) for different values of design parameter k ;

FIG. 16 is a plot of imaginary components of admittance Y_{im} vs. power for a prior art system utilizing a Chireix combiner and for a system provided in accordance with the novel concepts and techniques described herein;

FIG. 17 is a plot of effective conductance vs. P_{out} as seen by each of the Power Amplifiers (A-D) driving the 4-way combiner of FIG. 4 with $V_S=50\Omega$ and $k=1.05$ as a result of an inverse RCN outphasing control;

FIG. 17A is a plot of effective susceptance vs. P_{out} as seen by each of the Power Amplifiers (A-D) driving the 4-way combiner of FIG. 4 with $V_S=1V$, $R_L=50\Omega$ and $k=1.05$ as a result of an inverse RCN outphasing control;

FIG. 17B is a plot of effective phase vs. P_{out} as seen by each of the Power Amplifiers (A-D) driving the 4-way combiner of FIG. 4 with $V_S=1V$, $R_L=50\Omega$ and $k=1.05$ as a result of an inverse RCN outphasing control;

FIG. 18 is a plot of effective input conductance vs. P_{out} as seen by each of the Power Amplifiers (A-D) driving the 4-way combiner of FIG. 4 with $V_S=1V$, $R_L=50\Omega$ and $k=1.05$ as a result of optimal susceptance outphasing control;

FIG. 18A is a plot of effective susceptance vs. P_{out} as seen by each of the Power Amplifiers (A-D) driving the 4-way combiner of FIG. 4 with $V_S=1V$, $R_L=50\Omega$ and $k=1.05$ as a result of optimal susceptance outphasing control;

FIG. 18B is a plot of effective phase vs. P_{out} for the system of FIG. 4 as seen by each of the Power Amplifiers (A-D) driving the 4-way combiner of FIG. 4 with $V_S=1V$, $R_L=50\Omega$ and $k=1.05$ as a result of optimal susceptance outphasing control;

FIG. 19 is a plot of effective input conductance vs. P_{out} as seen by each of the Power Amplifiers (A-D) driving the 4-way combiner of FIG. 4 with $V_S=1V$, $R_L=50\Omega$ and $k=1.05$ as a result of optimal phase outphasing control;

FIG. 19A is a plot of effective susceptance vs. P_{out} as seen by each of the Power Amplifiers (A-D) driving the 4-way combiner of FIG. 4 with $V_S=1V$, $R_L=50\Omega$ and $k=1.05$ as a result of optimal phase outphasing control;

FIG. 19B is a plot of effective phase vs. P_{out} for the system of FIG. 4 as seen by each of the Power Amplifiers (A-D) driving the 4-way combiner of FIG. 4 with $V_S=1V$, $R_L=50\Omega$ and $k=1.05$ as a result of optimal phase outphasing control;

FIG. 20 is a plot of outphasing control angles θ and ϕ vs. P_{out} for the Optimal Phase (OP), Optimal Susceptance (OS), Inverse RCN (IRCEN) control methods for the 4-way combiner of FIG. 4 with $V_S=1V$, $R_L=50\Omega$, and $k=1.05$;

FIG. 21 is a plot of a worst-case effective input admittance phase magnitude seen by the PAs driving the 4-way combiner of FIG. 4 with $V_S=1V$, $R_L=50\Omega$, and $k=1.05$ as a result of the Optimal Phase (OP), Optimal Susceptance (OS) and Inverse RCN (IRCEN) outphasing control methods;

FIG. 21A is a plot of a worst-case effective susceptance magnitude seen by the PAs driving the 4-way combiner of FIG. 4 with $V_S=1V$, $R_L=50\Omega$, and $k=1.05$ as a result of the Optimal Phase (OP), Optimal Susceptance (OS) and Inverse RCN (IRCEN) outphasing control methods;

FIG. 22 is a plot of a worst-case effective input admittance phase magnitude seen by the PAs driving the 4-way combiner of FIG. 4 according to the Optimal Phase outphasing control for $k=1.1$ and $k=1.2$. Power axis is normalized to $V_S=1V$ and $R_L=1\Omega$; denormalize for a particular V_S and R_L by multiplying the power axis by V_S^2/R_L ;

FIG. 23 is a plot of Input admittance phase-minimizing design curves for a 4-way power combiner for the Inverse RCN (IRCEN) and the Optimal Phase (OP) outphasing control methods;

FIG. 24 is a normalized plot ($V_S=1V$, $R_L=1\Omega$) of the minimum and maximum limits of the output power operating range for which the peak phase deviation is minimized (admittance phase-minimizing design) versus the k -value for a 4-way power combiner for the Inverse RCN (IRCEN) and the Optimal Phase (OP) outphasing control methods;

FIG. 25 are plot of input susceptance-minimizing design curves for a 4-way power combiner for the Inverse RCN (IRCEN) and the Optimal Susceptance (OS) outphasing control methods;

FIG. 26 is a normalized plot ($V_S=1V$, $R_L=1\Omega$) of the minimum and maximum limits of the output power operating range for which the peak susceptive deviation is minimized (susceptance-minimizing design) versus the k -value for a 4-way power combiner for the Inverse RCN (IRCEN) and the Optimal Phase (OP) outphasing control methods;

FIG. 27 is a binary tree implementation of an 8-way power combiner;

FIG. 28 is T- Δ general network transformation;

FIG. 29 is T-to- Δ transformation applied to the top T-network of the 4-way combiner in FIG. 4.

FIG. 30 is a basic 4-way combiner with power amplifier inputs and load network connection shown;

FIGS. 30A-30D are four possible topological variations of the basic 4-way combiner of FIG. 30 as result of T- Δ transformations on portions of the network and load with power amplifier inputs and load network connection shown; and

FIGS. 31 and 31A-31D are circuits corresponding to topological duals of circuits in FIG. 30 and FIGS. 30A-30D with power amplifier inputs and load network connection shown.

DETAILED DESCRIPTION OF THE PREFERRED EMBODIMENTS

Referring now to FIG. 4, while conventional outphasing systems utilize two power amplifiers, a system configured in accordance with the concepts and techniques described herein combines power from four or more amplifiers. It should be appreciated that the power combiner is substantially lossless, and enables output power to be controlled by the relative phasing of the individual power amplifiers, while providing desirable input impedances at the power combiner inputs. It should also be appreciated that for a specified load resistance R_L , controlling output power P is equivalent to controlling the output voltage amplitude, since $P=V_{out}^2/(2R_L)$. It should also be noted that power may additionally be controlled through other methods, including amplitude modulation of the power amplifier inputs and modulation of the power supply/supplies of the power amplifiers (i.e. other techniques may be used in combination with outphasing techniques described herein).

It should also be appreciated that while the exemplary embodiment described herein below in conjunction with FIG. 4 includes four power amplifiers, in accordance with the concepts described herein, outphasing systems having more than four amplifiers are also contemplated and extensions to systems having more than four amplifiers are also described herein below.

Turning now to FIG. 4, an outphasing system includes a power combiner (or more simply a combiner) and a plurality of, here four, amplifiers which are shown modeled as ideal voltage sources in FIG. 4 (and as will be discussed below, FIG. 5 depicts the phasor relationship between the terminal voltages of the power amplifiers). The power combiner has five ports: four input ports coupled (directly or indirectly) to output ports of respective ones of four power amplifiers and one output port coupled (directly or indirectly) to a load. Ideally, the power combiner is provided as a lossless combiner comprised of a first set of reactive elements having impedances $Z=-jkx_1$ and $+jkx_1$ and a second set of reactive elements having impedances $Z=-jkx_2$ and $+jkx_2$ (it should be appreciated that in the art, combiners comprising ideally lossless components are often referred to as lossless combiners.) The reactive elements are each provided having specified reactance values at a desired operating frequency.

In the exemplary embodiment of FIG. 4, the power amplifiers are modeled as ideal voltage sources. It is recognized, however, that practical power amplifiers will not act as ideal sources when the effective loading impedance deviates from the ideal.

To provide an outphasing system such as that shown in FIG. 4, one can begin by describing how the reactances in the new combiner may be selected. The reactance magnitude X_2 of one element of the combiner is selected close to the load resistance R_L . For example, it is preferable that the reactance magnitude X_2 be typically within about 30% of load resistance R_L , and for many designs the reactance magnitude X_2 will be within about 10% of load resistance R_L . It should be appreciated that the parameter k sets how close X_2 is to R_L , as per Equation (1). The effects of varying k on the performance (and thus “how close” R_L and X_2 are) is discussed below in conjunction with FIG. 15 and FIGS. 23-26. In most practical embodiments, values for k are typically in the range of about 1-1.2 although values outside this range may also be used depending upon the requirements of a particular application. To determine reactance magnitude X_2 , one may specify a number k equal to or slightly greater than 1 (e.g., $k=1.05$) and determine X_2 as:

$$X_2 = R_L \frac{2}{k+1} \tag{1}$$

As will be described below in conjunction with FIG. 16, it should be appreciated that parameter k can be thought of as the amount into which an apparent input resistance of an RCN compression stage is compressed—e.g. to between x and kx . Such a view of parameter k is taken in connection with Equation (16) and the associated text.

In any event, once a reactance magnitude for X_2 is computed, a value corresponding to a reactance magnitude for X_1 may be computed in terms of X_2 and k , for example as:

$$X_1 = \frac{X_2}{k + \sqrt{k^2 - 1}} \tag{2}$$

Thus, for example, with $R_L=50\Omega$, one may choose $X_2=48.78\Omega$ and $X_1=35.60\Omega$ at the operating frequency of the system. It will be appreciated that other relative selections of R_L , X_1 and X_2 are possible within the scope of the general concepts described herein and may be desired in some applications. It will also be appreciated by those of ordinary skill in the art after reading this disclosure, when to make such other relative selections taking into account a variety of factors including but not limited to: the particular application for which the circuit is being used; a desired operating range of the power amplifiers; a load sensitivity of the power amplifiers; whether purely resistive loading or some reactive component is desired for optimum loading of the power amplifiers and other system design goals and requirements. Nevertheless, this represents one preferred embodiment of the invention.

The behavior of the network of FIG. 4 may be analyzed and a set of relations for controlling the output by outphasing of the sources may be developed. It can be shown that the relationship between the source voltages and input currents of the network of FIG. 4 can be expressed as:

$$\begin{bmatrix} I_A \\ I_B \\ I_C \\ I_D \end{bmatrix} = X_1^{-1} \begin{bmatrix} \gamma + j(1 - \beta) & -\gamma + j\beta & \gamma & -\gamma \\ -\gamma + j\beta & \gamma - j(\beta + 1) & -\gamma & \gamma \\ \gamma & -\gamma & \gamma + j(\beta + 1) & -\gamma - j\beta \\ -\gamma & \gamma & -\gamma - j\beta & \gamma + j(\beta - 1) \end{bmatrix} \begin{bmatrix} V_A \\ V_B \\ V_C \\ V_D \end{bmatrix} \tag{3}$$

in which:

$$\gamma = R_L/X_1 \text{ and } \beta = X_2/X_1.$$

In vector notation, this can be expressed as:

$$\vec{I} = \vec{Y} \cdot \vec{V} \tag{4}$$

A relative phase relationship can be proposed among the four sources. It should, however, be appreciated that the phases may also be adjusted together by an additional angle to control the absolute phase of the output. While other possibilities exist within the scope of this disclosure and the general concept disclosed herein, the following relationship among the sources is proposed:

$$\begin{bmatrix} V_A \\ V_B \\ V_C \\ V_D \end{bmatrix} = V_S \begin{bmatrix} e^{-j\phi} e^{-j\theta} \\ e^{j\theta} e^{-j\theta} \\ e^{-j\theta} e^{j\theta} \\ e^{j\theta} e^{j\theta} \end{bmatrix} \tag{5}$$

where V_S is the amplitude of the sources and ϕ and θ are the control angles used for outphasing.

Referring now to FIG. 4A, a power combiner system includes a reactive power combiner having four input ports and an output port. Each of four amplifiers PA_A , PA_B , PA_C , PA_D , which may be provided as power amplifiers, have an RF

output port coupled to a respective one of the four RF input ports of the reactive power combiner. The amplifiers are biased by a respective one of four bias (or supply) voltages $V_{s1}, V_{s2}, V_{s3}, V_{s4}$. The power combiner system also includes an amplifier driver circuit (PA Driver) which provides output signals corresponding to RF signals driving amplifiers PA_A-PA_D. Each of amplifiers PA_A-PA_D receive the signals provided thereto from the PA driver circuit and provide an amplified RF signal to the respective inputs of the reactive power combiner circuit. The PA driver circuit also receives feedback signals (here, such feedback signals coupled from the output of the reactive power combiner). It should be appreciated that PA driver circuit provides to amplifiers PA_A-PA_D signals having appropriately selected phase and amplitudes (selected as described herein below). Thus, PA driver circuit may also include an amplitude/phase control unit responsible for adjusting the amplitudes A_A - A_D and phases \square_A - \square_D of the input signals to the respective PAs based upon user command and feedback data. Exemplary techniques for controlling such a system are described herein. It should, of course, be appreciated that the reactive power combiner may have 2^N ports where N is greater than or equal to 2. In some applications, a power combiner system which includes a reactive power combiner having eight (8) input ports and an output port and eight amplifiers is preferred.

Referring now to FIG. 4B, a power combiner system includes a reactive power combiner having four input ports and an output port, four amplifiers PA_A-PA_D (which may, for example, be provided as power amplifiers), a power supply control unit responsible for adjusting the supply voltages (V_{s1} - V_{s4}) of the respective PAs, and PA driver circuit responsible for adjusting the amplitudes (A_A - A_D) and phases (\square_A - \square_D) of the input signals to the respective PAs based on user command and feedback data. In this exemplary embodiment, the power supply control circuit can adjust one or all of bias voltages V_{s1} - V_{s4} provided to respective ones of amplifiers PA_A-PA_D to further improve the efficiency of the power combiner system. As discussed above in conjunction with FIG. 4A, in some applications, a power combiner system which includes a reactive power combiner having eight (8) input ports and an output port and eight amplifiers is preferred.

Referring now to FIG. 5, the phase and control angle relationships among the sources V_A, V_B, V_C, V_D in FIG. 4 is shown graphically as per the relations of Equation (5). It should be noted that the four terminal voltages V_A, V_B, V_C, V_D have the same amplitude V_s . As can be seen in FIG. 5, the outphasing control angles ϕ and θ are used to regulate output power while maintaining desirable loading of the sources (e.g. the power amplifiers).

To characterize system behavior, one finds the effective admittance seen by each source for the stipulated phase relationships. In this example, this is done using Equation (5). The effective admittance at a combiner input port is the complex ratio of current to voltage at the port with all sources active. The effective admittances represent the admittances "seen" by the sources when they are operating under outphasing control. Combining Equations (3) and (5) and manipulating them, the following expressions for the effective admittances at the four combiner input ports can be found as shown in Equations (6) through (9) below:

$$Y_{eff,A} = X_1^{-1}(\gamma - \gamma\cos(2\phi + 2\theta) - \gamma\cos(2\phi) + \gamma\cos(2\theta) - \beta\sin(2\phi)) + jX_1^{-1}(1 - \beta - \gamma\sin(2\phi + 2\theta) - \gamma\sin(2\phi) + \gamma\sin(2\theta) + \beta\cos(2\phi)) \quad (6)$$

-continued

$$Y_{eff,B} = X_1^{-1}(\gamma - \gamma\cos(2\theta - 2\phi) - \gamma\cos(2\phi) + \gamma\cos(2\theta) + \beta\sin(2\phi)) + jX_1^{-1}(-1 - \beta - \gamma\sin(2\theta - 2\phi) + \gamma\sin(2\phi) + \gamma\sin(2\theta) + \beta\cos(2\phi)) \quad (7)$$

$$Y_{eff,C} = X_1^{-1}(\gamma - \gamma\cos(2\theta - 2\phi) - \gamma\cos(2\phi) + \gamma\cos(2\theta) + \beta\sin(2\phi)) - jX_1^{-1}(-1 - \beta - \gamma\sin(2\theta - 2\phi) + \gamma\sin(2\phi) + \gamma\sin(2\theta) + \beta\cos(2\phi)) \quad (8)$$

$$Y_{eff,D} = X_1^{-1}(\gamma - \gamma\cos(2\phi + 2\theta) - \gamma\cos(2\phi) + \gamma\cos(2\theta) - \beta\sin(2\phi)) - jX_1^{-1}(1 - \beta - \gamma\sin(2\phi + 2\theta) - \gamma\sin(2\phi) + \gamma\sin(2\theta) + \beta\cos(2\phi)) \quad (9)$$

It is readily observed that the effective admittances seen by sources A and D are complex conjugates, as are those seen by sources B and C. Moreover, the expressions all have many individual terms in common.

Next, an outphasing control strategy for realizing a desired output power while preserving desirable (resistive) loading of the sources is described. Without loss of generality, consider synthesis of a zero-phase referenced output voltage at the load. One may adjust the load phase by common adjustments to all of the power amplifier phases. To synthesize a zero-phase load voltage of amplitude $V_{L,ref}$ or equivalently a "commanded" cycle-average power $P_{cmd} = (V_{L,ref})^2 / (2R_L)$, an intermediate variable r_o is defined as shown in Equation (10):

$$r_o = \frac{2V_s^2}{P_{cmd}} \quad (10)$$

control angles θ and ϕ are selected in terms of r_o in accordance with Equations (11) and (11A):

$$\theta = \text{ATAN}\left(\frac{2r_o X_2}{r_o^2 + X_1^2}\right) \quad (11)$$

$$\phi = \text{ATAN}\left(\frac{X_1}{r_o}\right) \quad (11A)$$

It will be appreciated that other control selections of θ and ϕ are possible within the scope of this disclosure, and may be desired in some applications. Equations (10)-(11A) form the complete suggested control law in terms of desired power P_{cmd} which we term the "approximate inverse resistance compression network" control method, or AIRCN control method, and this represents one preferred embodiment. Advantages include having a strong analytical basis, and ease of generating the angles and handling the phase modulation using the approach described in the last section of the extended digest.

It should, of course, be appreciated that it is possible to come up with alternative formulations of control that could provide similar control of power while keeping the imaginary part of the effective admittance small. This could be done, for example, by performing a search, such as a numerical search, for alternative angle combinations that provide desired power points, perhaps starting the search near the solution shown above. Two such control methods, referred to herein as the "optimal phase" (or "OP") control method and the "optimal susceptance" (or "OS") control method are described below. These methods represent alternative preferred embodiments which are preferable for the very low (and in some cases minimized) phase and susceptance deviations they achieve.

The Table I below shows the achievable performance of a four (4) way combiner (e.g. of the type described above in conjunction with FIGS. 4-4B) with IRCN and OP control.

TABLE I

Power Ratio	Power Ratio (dB)	IRCNCN Peak Phase (Deg)	OP (~OS) Peak Phase (Deg)
2	3.01	0.07	0.01
5	6.99	0.78	0.31
10	10	3.05	1.15
20	13.01	8.18	3.01
50	16.99	25.36	9.35

Table II shows an eight (8) way combiner maximum worst-case effective input admittance phase for the 5:1, 10:1, 20:1, 50:1, and 100:1 power range ratios for the case of an Inverse RCN (IRCNCN) outphasing control method.

TABLE II

Power Ratio	Power Ratio (dB)	Max Worst Case Phase (Deg)	Phase Margin (Deg)
5	6.99	0.01	1
10	10	0.03	1
20	13.01	0.18	1
50	16.99	1.08	2
100	20	3.06	4

It should be appreciated that for phase values less than one degree in Table II, as a practical matter one degree could act as a bound (i.e. phase values within a few degrees would be sufficient for many practical applications).

It should, of course, be appreciated that it is also possible to implement control laws that additionally control the common phase among the power amplifiers and/or differential phases among the amplifiers as a function of the dynamics of the desired magnitude and phase of the output signal. The control law can thus specify the phases of the power amplifiers as a function of not only output power/voltage and phase, but also based upon the derivative of desired output voltage and phase, or some other function of the dynamics of the desired signal output and/or the power amplifier network. This can be used to compensate for rapid phase variation of the desired output signal for example (e.g., to mitigate out-of-band components in the output) and/or to compensate for the natural response of the combiner network.

It should also be appreciated that concepts, system and techniques described herein are the first-ever outphasing of more than two PAs with a lossless combiner network that provides desirable loading characteristics of the PAs and that the above-referenced control laws represents one preferred embodiment of the novel concepts, system and techniques described herein. As will be seen, for typical parameter selections, (e.g. of the parameter k in the range 1-1.2, and the circuit values X_1 and X_2 which result from this selection through the process described herein) this control law provides monotonic output control and desirable loading of the individual power amplifiers over a wide operating range.

It is useful to know the load voltage V_L and the output power P_{out} delivered to the load R_L (see FIG. 4) for a given pair of outphasing control angles $[\theta; \phi]$. By employing straightforward linear circuit analysis techniques, it can be shown that the load voltage is given by (12):

$$V_L = j \frac{R_L}{X_1} (V_B + V_D - V_A - V_C). \quad (12)$$

As a result of the adopted PA phase relationship of FIG. 5, the above equation further reduces to (13):

$$V_L = - \frac{4R_L}{X_1} V_s \sin(\phi) \cos(\theta). \quad (13)$$

Consequently, the output power is easily determined according to (14):

$$P_{out} = \frac{V_L^2}{2R_L} = \frac{8R_L V_s^2}{X_1^2} \sin^2(\phi) \cos^2(\theta). \quad (14)$$

Equation (14) is of great importance and value as it concisely expresses the exact relationship between the output power delivered to the load R_L and any pair of outphasing control angles $[\theta; \phi]$.

Moreover, it can be readily seen from Equation (14) that the maximum output power deliverable to the load by the power combiner, the saturated output power $P_{out,sat}$ is given by (15), and corresponds to $\theta=0^\circ$ and $\phi=90^\circ$.

$$P_{out,sat} = \frac{8R_L V_s^2}{X_1^2}. \quad (15)$$

Although Equation (15) is valid only for the 4-way combiner, the only difference between it and that for the general N-way combiner is the leading numeric constant, which can be determined by applying the methodology outlined above.

Next described are attributes of the proposed power combiner and outphasing system. As an example, consider a system having $V_s=1$ V, $R_L=50\Omega$ and a design value $k=1.05$ (resulting in $X_2=48.78\Omega$ and $X_1=35.60\Omega$).

FIG. 6 shows plots of the control angles ϕ and θ versus "commanded" power, as per Equations (10)-(12) for the example system ($V_s=1$ V, $R_L=50\Omega$, $X_2=48.78\Omega$ and $X_1=35.60\Omega$) for the AIRCNCN control method.

FIG. 7 is a plot of actual output power vs. commanded power for the example system having $V_s=1$ V, $R_L=50\Omega$, $X_2=48.78\Omega$ and $X_1=35.60\Omega$. As can be seen from FIG. 7, the actual power increases monotonically from zero with commanded power, and matches the commanded power well over the range shown. At higher commanded power levels the actual power achieved saturates at approximately 0.31 W. Because the output power is a smooth, monotonic function of command down to zero power, the nonlinearity can be readily addressed through predistortion or other means. This result demonstrates that the novel outphasing scheme described herein can smoothly control output power over a wide range down to zero power.

Also of practical importance are the effective impedances seen by the individual power amplifiers across the control range.

Referring now to FIGS. 8 and 8A, shown are the real and imaginary components of the effective admittances at the four combiner input ports as a function of the commanded cycle-average output power P_{cmd} for the AIRCNCN control method (as per Equations (6)-(11A)).

The plots are shown for the example $R_L=50\Omega$, $X_2=48.78\Omega$ and $X_1=35.60\Omega$ over a commanded power range of [0.01, 0.25] W. Comparing FIGS. 8 and 8A, it can be seen that the imaginary components are small compared to the real components over a wide range (i.e., highly conductive input admittances). Below the range shown, as commanded power goes to zero, the real parts of the admittances go to zero, while

the imaginary parts go to ± 0.028 Mhos. The real parts of $Y_{eff,A}$ and $Y_{eff,D}$ briefly go negative for $P_{cmd} < 0.00875$ W, with a minimum negative real component of -0.026 Mhos. This indicates power transfer from sources V_B and V_C to V_A and V_D over this range. As P_{cmd} is increased above the range shown, real components of the admittances saturate at values in the range 0.15-0.16 Mhos, with imaginary parts saturating to values in the range of $[-0.075, 0.075]$ Mhos.

FIGS. 9 and 9A show the same information as magnitude and phase of the effective impedances.

The plots of FIGS. 7 and 8 and 9 illustrate some important characteristics of the system.

For example, it can be seen that the input admittance at each port is highly resistive (phase close to zero) over a wide range of power commands, and that the susceptive component of the admittance is never large on an absolute scale. This represents a nearly-ideal loading characteristic for many kinds of power amplifiers: the susceptive portions of the effective admittances loading the power amplifiers are small and the conductive components of the admittances are closely matched and scale up with desired power delivery. At very low commanded powers (e.g. below the range illustrated in FIGS. 8 and 9), the admittances do increase and become susceptive (becoming entirely susceptive at zero commanded power). However, as the source currents and power drawn in this range are small, this nonideality will be tolerable in many applications. In fact, the susceptive loading is small over a substantially wider power range than with conventional Chireix outphasing, for example. Likewise, the susceptive component of loading can be made smaller over a specified power range than is achievable with conventional Chireix outphasing.

Referring briefly to FIG. 16, a comparison is shown between the imaginary components of admittances of the new power combiner and outphasing system (FIG. 4) and AIRCN control method to that of the Chireix system of FIG. 3 as a function of total output power. Three example designs of the Chireix system are shown. The Chireix systems are shown for a factor of $\sqrt{2}$ higher input voltage to account for the fact that a Chireix system only has two PAs. With this normalization, the same total power is achieved in the two systems with each PA seeing similar real components of admittance. It can be seen that the new power combining and outphasing system yields much smaller reactive loading than the Chireix combiner over a wide power range. (For reference, the real part of the admittances for $P_{out}=0.2$ W are each approximately 0.1 Mho.)

These results demonstrate that the proposed power combiner and outphasing system can meet the goal of providing wide-range power control at high efficiency while preserving desirable loading characteristics of the individual power amplifiers. An advantage of the novel system described herein is that one can achieve smaller susceptive loading over a specified power range with the proposed outphasing system than one can with a Chireix combiner. Likewise, for a specified allowable magnitude of susceptive loading one can operate over a greater power range with the proposed system than one can with a Chireix combiner.

Referring now to FIGS. 9 and 9A, magnitude and phase of the effective admittances at the four power combiner input ports, plotted as a function of the power command P_{cmd} are shown. The curves in FIGS. 9 and 9A were generated for the example $R_L=50\Omega$, $X_2=48.78\Omega$ and $X_1=35.60\Omega$ over the commanded power range of $[0.01, 0.25]$ W with the AIRCN control method. It can be seen that the input admittance is highly conductive (phase close to zero) over a wide range and is

ideally zero at four output power levels. As commanded power goes to zero below the range shown, the admittance magnitudes increase to a maximum of ~ 0.28 Mhos, and the phases go to $\pm 90^\circ$. As commanded power increases above the range shown, input admittance magnitudes saturate to values below ~ 0.18 Mhos, with phases in the range of $[-25^\circ, 25^\circ]$.

To validate the above results, the system of FIG. 4 was simulated in LTSPICE with the proposed AIRCN control law set for the in Equations (10), (11) and (11A) at a frequency of 10 MHz. The example $V_s=1$ V, $R_L=50\Omega$ and $X_2=48.78\Omega$ and $X_1=35.60\Omega$ was used. Positive reactances were implemented with inductors (566.6 nH for X_1 and 776.4 nH for X_2), while negative reactances were implemented with capacitors (447 pF for X_1 and 326.27 pF for X_2). The effective admittances at the four power amplifier ports and the power were calculated numerically for a range of operating points. The simulation results were found to match the theory within the numerical precision of the simulation. An example of simulation results matching the theory within the numerical precision of a simulation shown in FIGS. 10 and 10A.

Referring now to FIGS. 10 and 10A, these figures show real and imaginary components of the effective admittance $Y_{eff,C}$ for the example $V_s=1$ V, $R_L=50\Omega$, $f=10$ MHz, $X_2=48.78\Omega$ and $X_1=35.60\Omega$ and the AIRCN control method. Both analytical results and numerical results computed from LTSPICE .ac simulations are shown. For simulation, positive reactances were implemented with inductors (566.6 nH for X_1 and 776.4 nH for X_2), while negative reactances were implemented with capacitors (447 pF for X_1 and 326.27 pF for X_2). The simulation results confirm the analytical formulation.

Thus, FIGS. 10 and 10A represent one example of simulation results matching the theory within the numerical precision of a simulation. FIGS. 10 and 10A show the analytical curves showing the effective admittance $Y_{eff,C}$ along with values computed numerically based on simulations. Simulation matched theory equally well for the other effective admittances not shown in FIGS. 10 and 10A.

A concern with any power combining system is the efficiency of power combining. While ideally lossless, the parasitic resistances of actual passive components in the combiner of FIG. 4 contribute a degree of loss which often cannot be neglected. Here we consider the impact of such losses on power combiner efficiency. We treat only losses owing to the power combiner, and do not consider any combining-related losses that may accrue in the power amplifiers themselves (e.g., owing to variations in effective impedance at the power combiner input ports).

To model non-idealities of the passive components in the combiner of FIG. 4, we assume that each branch in the combiner network has a series resistance such that every branch has the same quality factor $Q=|X|/R_s$. To estimate the losses and efficiency degradation owing to these parasitic resistances, we adopt a method that has been previously employed in matching networks: the circuit currents are calculated assuming no loss (i.e., assuming the resistances are zero); the losses and circuit efficiency are then calculated based on the losses induced by the calculated currents flowing through the parasitic resistances. This method thus assumes that the branch currents are not significantly affected by the presence of small resistances.

Using the above method, it can be shown that the loss in the combiner can be calculated as shown in Equation (16):

$$P_{loss,av} = \frac{1}{2Q} \vec{V}^H [Y^H W Y] \vec{V} \quad (16)$$

Where V and Y are defined as in Equations (3) and (4), H is the Hermetian operator (conjugate transpose) and W is defined as shown in Equation (17):

$$W = \begin{bmatrix} |X_1| + |X_2| & |X_2| & 0 & 0 \\ |X_2| & |X_1| + |X_2| & 0 & 0 \\ 0 & 0 & |X_1| + |X_2| & |X_2| \\ 0 & 0 & |X_2| & |X_1| + |X_2| \end{bmatrix} \quad (17)$$

The fractional loss fl=(1-efficiency) of the combiner can be similarly calculated as shown in Equation (18):

$$fl = 1 - \eta = \frac{1}{Q} \cdot \frac{\vec{V}^H [Y^H W Y] \vec{V}}{\vec{V}^H Y \vec{V}} \quad (18)$$

The fractional loss is thus inversely proportional to the quality factor of the branch impedances in the combiner network, and depends on the operating point.

To validate the above formulation and to illustrate the efficiency potential of the proposed power combining system, the fractional loss of an example system was calculated using the result of Equation (14) and compared to numerical results from LTSPICE. The example $V_s=1$ V, $R_L=50\Omega$, $f=10$ MHz, $X_2=48.78$ and $X_1=35.60\Omega$ and the AIRCN control method is again used. Positive reactances were implemented with inductors (566.6 nH for X_1 and 776.4 nH for X_2), while negative reactances were implemented with capacitors (447 pF for X_1 and 326.27 pF for X_2), and parasitic resistances are added for $Q=100$ of each branch element.

FIG. 11 is a plot of percentage power loss in the combiner (100-fl) vs. commanded input power for the example $V_s=1$ V, $R_L=50\Omega$, $f=10$ MHz, $X_2=48.78\Omega$ and $X_1=35.60\Omega$ for component quality factors $Q=100$. Both analytical results and numerical results computed from LTSPICE .ac simulations are shown. For simulation, positive reactive impedances were implemented with inductors with series resistors (566.6 nH, 0.356 Ω for X_1 and 776.4 nH, 0.488 Ω for X_2), while negative reactive impedances were implemented with capacitors with series resistors (447 pF, 0.356 for X_1 and 326.27 pF, 0.488 Ω for X_2). The simulation results confirm the analytical formulation. The small mismatch between the theoretical curve and the simulated results can be attributed to the assumption made in the analysis that the small resistive losses do not affect the current waveforms. Moreover, it can be seen that the loss owing to power combining is small over a wide operating range (<5% over the plotted range for $Q=100$). As fractional loss (or percentage loss) is inversely proportional to branch quality factor, we can see that combining loss is expected to be manageable even at relatively low quality factors, and can be made quite low if high-quality-factor components are used.

Next described is a conceptual framework to facilitate understanding of the proposed power combining and outphasing system. In addition to better illustrating the operating principles of the system, this section explains how the design of circuits and systems describe above in conjunction with FIGS. 4-11 are synthesized, and shows how related power combiners and control laws within the scope of the concepts,

systems and techniques described herein can be developed. As a first step, a seemingly-unrelated problem is discussed: the development of multi-stage resistance compression networks. It is then shown how the design and behavior of multi-stage compression networks can be used for synthesis of combiners and outphasing control laws.

As a route to illustrating the design and behavior of the proposed outphasing system, multi-stage resistance compression networks are first discussed. Resistance Compression Networks (RCNs) are a class of lossless interconnection networks for coupling a source to a set of matched (but variable) resistive loads.

Referring now to FIGS. 12 and 12A, a resistance compression network (RCN) (FIG. 12) and its operating characteristic (FIG. 12A) are shown. FIG. 12A illustrates the resistive input impedance R_{in} of the RCN of FIG. 12 as a function of the matched load resistance value R_o . As can be seen in FIG. 12A, as the resistance values of the matched load resistance R_o vary together over a range geometrically-centered on X, the value of the input impedance is resistive and varies over a much smaller range than R_o . It should be noted that RCN networks have application to resonant dc-dc converters and rectifiers and to energy recovery in power amplifiers among other applications.

As the resistances R_o in the RCN of FIG. 12 vary together over a range geometrically-centered on X, the input impedance of the network is resistive and varies over a much smaller range than R_o varies. In particular, it can be shown that the input impedance is resistive at the operating frequency and is a function of the load resistance. This can be expressed as shown in Equation (19):

$$R_{in} = f(R_o) = \frac{R_o^2 + X^2}{2R_o} \quad (19)$$

As the load resistances R_o vary over the range $[X/b, bX]$, the input resistance varies over the range $[X, kX]$, where k and b are related as shown in Equation (20):

$$b = k + \sqrt{k^2 - 1} \quad \text{and} \quad k = \frac{1 + b^2}{2b} \quad (20)$$

Because the input impedance is resistive and varies over a much smaller range than the matched load resistances R_o , RCN networks are advantageous in applications such as resonant rectifiers and dc-dc converters.

Multi-stage RCNs offer the possibility of even smaller input resistance variations (or wider load resistance ranges) than single-stage designs. Here we present for the first time the design of a multi-stage RCN to provide a specified maximum peak deviation in input resistance away from a desired median input resistance value, and determine the load resistance range over which this can be accomplished. In particular, we consider the design of the multi-stage resistance compression network shown in FIG. 13. We will subsequently show how this RCN relates to the outphasing system of FIG. 4.

Referring now to FIG. 13, a multi-stage resistance compression network is provided from a cascade of single-stage RCN networks which may be the same as or similar to the type described in conjunction with FIG. 12. A source V_L driving the network is also shown. The RCN of FIG. 13 can be

21

provided such that the input resistance $R_{in,2}$ varies much less than the matched load resistances R_o .

Suppose one would like to design the RCN of FIG. 13 to provide an input resistance $R_{in,2}$ within $\pm\Delta R$ of a desired median value $R_{in,2,med}$ over as wide a range as possible. To do this, a value k_2 (stage 2 input resistance ratio) is selected as shown in Equation (21):

$$k_2 = \frac{R_{in,2,med} + \Delta R}{R_{in,2,med} - \Delta R} \quad (21)$$

and select a stage two reactance magnitude as shown in Equation (22)

$$X_2 = \frac{2R_{in,2,med}}{k_2 + 1} \quad (22)$$

which yields a value as shown in Equation (23):

$$R_{in,2,med} = \frac{k_2 + 1}{2} X_2 \text{ and } \Delta R = \frac{k_2 - 1}{2} X_2. \quad (23)$$

Next one considers selecting the stage one reactance magnitude X_1 to provide compression into a range that makes best use of the second stage. The effective resistance $R_{in,1}$ seen at the inputs of the first stage has a minimum value of X_1 , so to maximize the R_o range over which we achieve the desired compression we select X_1 , as shown in Equations (24):

$$X_1 = \frac{1}{b_2} X_2 \quad (24)$$

where b_2 is determined from k_2 as per Equation (20). $R_{in,1}$ has a maximum value of $k_1 X_1$ where the operating range over which the desired degree of compression is achieved is found from Equation (25):

$$R_{in,1,max} = k_1 X_1 = b_2 X_2 \quad (25)$$

The desired degree of compression over an operating range of R_o in $[X_1/b_1, b_1 X_1]$ where b_1 can be determined from Equations (20) and (25).

Referring now to FIG. 14, a plot which shows how the input resistance $R_{in,2}$ varies as a function of matched load resistance R_o when compression network values are selected as described above (e.g. for the two-stage compression network of FIG. 13) is shown. Selection of the compression network reactances as described provides this characteristic, which compresses resistance to a much greater extent than is possible in a single-stage compression network. For example, one can achieve resistance compression of the input resistance to within $\pm 2.5\%$ of the desired median value over a 12:1 ratio in load resistance R_o with this technique. Similar levels of performance can be obtained using other types of compression stages. Moreover, even greater levels of resistance compression (or similar resistance deviations over wider ranges of load resistance) can be achieved with more stages.

As a final note, one will find it useful in the following section to know the load voltage V_A - V_D in terms of the drive voltage V_L . It can be shown that the relation expressed in Equation (26) holds for these voltages:

22

$$\begin{bmatrix} V_A \\ V_B \\ V_C \\ V_D \end{bmatrix} = V_L \frac{\sqrt{R_o^2 + X_1^2}}{2\sqrt{\left(\frac{R_o^2 + X_1^2}{2R_o}\right)^2 + X_2^2}} \begin{bmatrix} e^{-j\theta} e^{-j\phi} \\ e^{j\theta} e^{-j\phi} \\ e^{-j\theta} e^{j\phi} \\ e^{j\theta} e^{j\phi} \end{bmatrix} \quad (26)$$

where

$$\theta = \text{ATAN}\left(\frac{2R_o X_2}{R_o^2 + X_1^2}\right) \quad (27)$$

and

$$\phi = \text{ATAN}\left(\frac{X_1}{R_o}\right). \quad (28)$$

The phase relationship of these voltages is the same as that of the outphasing angles described in FIG. 5.

Next is provided a description of how the design and behavior of multi-stage compression networks can be used for synthesis of power combiners and outphasing control laws.

Consider the two-stage RCN shown in FIG. 13. Suppose we take this network, and change the sign of every reactance and resistance. This is equivalent to taking the network of FIG. 13 and applying type 1 time-reverse duality and then applying type 3 time reverse duality. Neglecting the impact upon the natural response of the circuit (which would become unstable), the sinusoidal steady-state behavior of such a circuit would have all current flow directions reversed, while preserving voltage relationships in the circuit, thus yielding reversed power flow (i.e. from the—now negative—resistors to the voltage source V_L . The ratio of the voltage V_L to the current flowing into V_L would be that of $R_{in,2}$ of the original compression circuit, which is close to the value $R_{in,2,med}$. Likewise, the voltages at the now-negative resistors would be as described in Equation (26), and currents proportional to these voltages would flow into the network (i.e., the apparent impedances seen looking into the network ports to which the negative resistances are connected would be resistive with values $|R_o|$.)

To develop a power combining and outphasing system, we take advantage of the above observations. In particular, we replace the source V_L in FIG. 14 with a load resistance $R_L = R_{in,2,med}$ and replace the resistors R_o with voltage sources (or power amplifiers in practice). This leads directly to the system of FIG. 4. Controlling the phases of the sources to match their behavior in the original two-stage resistance compression network, we can then obtain power control over a wide range while preserving nearly resistive loading of the sources (compare Equations (27), (28) to Equations (11), (11A)). While these substitutions do not lead to precise duality between RCNs and the proposed power combining and outphasing system, this approach nonetheless provides a means to develop effective outphasing and power combining systems such as described above in conjunction with FIGS. 4-11.

It will be appreciated that a wide variety of high-performance power combining and outphasing systems within the scope of the inventive concepts described herein can be synthesized through the approach described above. This includes designs based on multi-stage cascades of various types of compression network structures. For example, a three-level structure designed similarly (using 8 sources) as illustrated in

FIG. 27 would yield even wider-range power control for a given allowable susceptible loading of the sources and a smaller achievable susceptance for a specified power control range. Likewise, using the topological dual of the RCN in FIG. 12 in a multi-stage design would likewise be effective as the basis for a combiner. Moreover, one could combine different types of base RCN circuits to construct effective combiners. It should be noted that for some types, all of the sources and/or loads may not be referenced to common potentials, so one may elect to use transformers or baluns to provide coupling. Finally, use of topological and/or time-reverse duality transformations will yield other combiner systems within the scope of the inventive concepts described herein as will network transformations such as T-Δ transformations.

Numerous other circuit opportunities also present themselves. The reactances in FIG. 4 are specified only at a single frequency, and one may choose to implement them with single inductors or capacitors as appropriate. However, one may also use higher-order reactive networks in developing networks within the scope of the invention. These may be selected to block or conduct dc- and/or higher-order harmonics, or to present desired impedances (e.g., for combining and outphasing) at harmonic frequencies or other desired operating frequencies. Likewise, while the development has been described in terms of lumped parameter elements, it will be appreciated that distributed elements (e.g., based on transmission-line networks) can likewise be used.

There is also flexibility of design within a combiner structure and control law. For example, the design discussed above in conjunction with FIGS. 4-11 utilized a value of design parameter k of 1.05. Different values of k may be selected based upon system design goals and requirements, such as the desired operating range and load sensitivities of the power amplifiers.

Referring now to FIGS. 15 and 15A, plots of the effective admittance $Y_{eff,A}$ in the combiner of FIG. 4 and control laws of Equations (10)-(11A) (AIRCN control method) for different values of design parameter k are shown. By examining FIGS. 15 and 15A, it can be seen that higher values of k provide a higher upper bound in achievable power delivery, but also results in greater phase variations over the operating range. Thus, FIGS. 15, 15A for example, show the influence of design parameter k on the effective admittance $Y_{eff,A}$.

Next described is a method for selecting power combiner reactance values. It should, of course, be appreciated that other techniques for selection of power combiner reactance magnitudes also exist.

The following methodology is proposed for selecting the reactances X_1 and X_2 of the power combiner in FIG. 4. The reactance magnitude X_2 is selected close to the load resistance R_L . In particular, a number k equal or slightly greater than 1 (e.g., $k=1.05$) can be specified, and X_2 can be determined as:

$$X_2 = \frac{2R_L}{k+1}. \quad (28)$$

The reactance magnitude X_1 is then selected in terms of X_2 and k according to:

$$X_1 = \frac{X_2}{k + \sqrt{k^2 - 1}}. \quad (29)$$

The above approach for selecting the reactance magnitudes originates from the design of Resistance Compression Networks (RCNs). That is, the relative reactances are selected based upon how one might design a resistance compression network to minimize peak deviations of the input resistance from a median value according to the methods in the section on Multi-Stage Resistance Compression. The performance and behavior of each power combiner with reactances selected as outlined above are uniquely determined by the particular k -value. Guidelines and techniques for selecting the appropriate value of k in order for the power combiner to satisfy specific performance specifications are discussed later in this document. Each of the outphasing control strategies disclosed below assume that X_1 and X_2 have been determined according to (28) and (29).

Moreover, this approach can easily be generalized for a 2^N -way combiner with analogous implementation to that of FIG. 4 by first determining the appropriate value for k_N , and then applying the following recursive relations:

$$X_N = \frac{2R_L}{k_N + 1}, \quad b_N = k_N + \sqrt{k_N^2 - 1} \quad (30)$$

$$X_{n-1} = \frac{X_n}{b_n} \quad \text{and} \quad b_{n-1} = b_n^2 + \sqrt{b_n^4 - 1} \quad \text{for } 1 \leq n \leq N. \quad (31)$$

Next described are multiple outphasing control strategies that are in accordance with the present invention. One outphasing control strategy is based upon an inverse resistance compression network (IRCN) outphasing control technique (also referred to as the IRCN method). The IRCN outphasing control technique results by analogy of (approximate) reverse operation of a resistance compression network processing similar levels of power. That is, the PAs driving the combiner are appropriately outphased so that their terminal voltage phases match the voltage phases of the load resistances in the original RCN (i.e., the RCN which approximates the double time-reverse dual of the combiner). As a result, the power delivered to load R_L driven by the power combiner is approximately equivalent to the power that would be delivered by a power source driving the original RCN and having the same terminal voltage as R_L . This outphasing control method yields desirable loading (almost entirely conductive effective input admittance) of the PAs. Moreover, due to this control method, the necessary outphasing control angles can be computed conveniently via a set of analytical expressions which are valid over the entire output power operating range of the combiner.

For the case of the 4-way power combiner in FIG. 4, the outphasing control angles θ and ϕ for a particular load R_L and PA voltage amplitude V_S are given by Equation (32) with the variable R_o determined according to Equation (33). It can be further shown that ϕ is a monotonic function of power P_{out} for every value of $k \geq 1$.

$$\theta = \text{ATAN}\left(\frac{2R_o X_2}{R_o^2 + X_1^2}\right) \quad \text{and} \quad \phi = \text{ATAN}\left(\frac{X_1}{R_o}\right) \quad (32)$$

25

-continued

$$R_o = \sqrt{\frac{\frac{4R_L V_S^2}{P_{out}} - X_1^2 - 2X_2^2 + \sqrt{2\sqrt{\frac{4R_L^2 V_S^4}{P_{out}^2} - \frac{4R_L V_S^2 X_2^2}{P_{out}} + X_1^2 X_2^2 + X_2^4}}}{2}} \quad (33)$$

It should be noted here that we may think of P_{out} in Equation (33) as the desired output power (the command input), which will also be the actual output power under ideal conditions (e.g., with precise component values and zero combiner loss). The difference between this IRCN method and the closely-related AIRCN method described above is that the IRCN method uses a more exact (but more complicated) expression to relate the commanded power (P_{cmd} or P_{out}) to the intermediate variable (r_o or R_o) in finding the control angles. For example, compare Equations (10)-(11A) to Equation (32) and (33). Nevertheless, both the IRCN and AIRCN control methods result in equivalent effective input admittance characteristics versus actual output power delivered by the power combiner to the load. It is readily observable from Equations (1)-(4) and (32) that for zero output power ($P_{out}=0$), all PA voltages are in phase ($\theta=0^\circ$, $\phi=0^\circ$) and the effective input admittances (purely susceptive) may be expressed as shown in Equation (34):

$$Y_{eff,A} = Y_{eff,C} = jX_1^{-1}$$

$$Y_{eff,B} = Y_{eff,D} = -jK_1^{-1} \quad (34)$$

At saturated output power $P_{out,sat}$ ($\theta=0^\circ$, $\phi=90^\circ$) the effective input admittances are given by Equation (35)

$$Y_{eff,A} = X_1^{-1}(4\gamma + j(1-2\beta))$$

$$Y_{eff,B} = X_1^{-1}(4\gamma + j(-1-2\beta))$$

$$Y_{eff,C} = X_1^{-1}(4\gamma - j(-1-2\beta))$$

$$Y_{eff,D} = X_1^{-1}(4\gamma - j(1-2\beta)) \quad (35)$$

and the maximum phase ϕ associated with them is provided by Equation (36), where $\gamma=R_L/X_1$, $\beta=X_2/X_1$:

$$\phi = \text{ATAN}\left\{ \frac{1 + 2(k + \sqrt{k^2 - 1})}{2(k + 1)(k + \sqrt{k^2 - 1})} \right\} \quad (36)$$

As an example, FIGS. 17, 17A and 17B depict the effective input conductance, susceptance and phase seen by each of the PAs driving the power combiner of FIG. 4 with $V_S=1V$, $R_L=50\Omega$, and $k=1.05$ and the IRCN control method. It should be understood that nonidealities such as parasitic losses are not considered, so no distinction is made between commanded and actual output power.

The output power levels at which all four susceptive components of the effective input admittances become zero (referred to as a zero-point) can be computed according to Equations (37)-(40).

$$P_{out,zp1} = 2V_S^2 \left(R_L + \sqrt{R_L^2 - X_2^2} - \sqrt{2R_L^2 - X_1^2 - X_2^2 + \frac{2R_L^3 - 2R_L X_2^2}{\sqrt{R_L^2 - X_2^2}}} \right)^{-1} \quad (37)$$

26

-continued

$$P_{out,zp2} = 2V_S^2 \left(R_L + \sqrt{R_L^2 - X_2^2} + \sqrt{2R_L^2 - X_1^2 - X_2^2 + \frac{2R_L^3 - 2R_L X_2^2}{\sqrt{R_L^2 - X_2^2}}} \right)^{-1} \quad (38)$$

$$P_{out,zp3} = 2V_S^2 \left(R_L - \sqrt{R_L^2 - X_2^2} - \sqrt{2R_L^2 - X_1^2 - X_2^2 - \frac{2R_L^3 - 2R_L X_2^2}{\sqrt{R_L^2 - X_2^2}}} \right)^{-1} \quad (39)$$

$$P_{out,zp4} = 2V_S^2 \left(R_L - \sqrt{R_L^2 - X_2^2} + \sqrt{2R_L^2 - X_1^2 - X_2^2 - \frac{2R_L^3 - 2R_L X_2^2}{\sqrt{R_L^2 - X_2^2}}} \right)^{-1} \quad (40)$$

Another control methodology is referred to as optimal susceptance outphasing control. This strategy is characterized with the following two main advantages: (1) minimizes the effective input susceptance seen by the PAs at each power level, and (2) achieves even susceptive loading amplitude of the PAs over the desired output power operating range.

For the 4-way combiner described hereinabove in conjunction with FIG. 4, the optimal susceptance control angle pair $[\theta; \phi]$ can be computed for a particular output power level P_{out} by numerically minimizing the largest effective input admittance susceptance S_{max} seen by any of the PAs (at P_{out}) subject to the constraint of Equation (41):

$$S_{max} = \max\{|\text{Im}\{Y_{eff,A}\}|, |\text{Im}\{Y_{eff,B}\}|\} \quad (41)$$

$$P_{out} = \frac{8R_L V_S^2}{X_1^2} \sin^2(\phi) \cos^2(\theta) \quad (42)$$

Appropriate control angles as a function of power for a given design can be found using numerical methods. Also, it can be shown that for the range of output power levels given by Equation (43), the solutions of the preceding optimization problem of Equations (41), (42) reduce to a set of convenient analytical expressions for calculating the control angles given by Equation (43).

$$\frac{4R_L^2 V_S^2 - 2V_S^2 \sqrt{4R_L^4 - R_L^2 X_1^2}}{X_1^2 R_L} \leq P_{out} \leq \frac{4R_L^2 V_S^2 + 2V_S^2 \sqrt{4R_L^4 - R_L^2 X_1^2}}{X_1^2 R_L} \quad (43)$$

$$\theta = \text{ACOS}\left(\sqrt{\frac{4V_S^4 + P_{out}^2 X_1^2}{8P_{out} R_L V_S^2}}\right) \text{ and } \phi = \text{ATAN}\left(\frac{P_{out} X_1}{2V_S^2}\right) \quad (44)$$

As an example, FIGS. 18, 18A, and 18B show a plot of the effective input conductance, susceptance and phase seen by each of the PAs driving the power combiner of FIG. 4 with $V_S=1V$, $R_L=50\Omega$, and $k=1.05$ with Optimal Susceptance (OS) control. The zero-points occur at the same output power levels as in the case of the Inverse RCN outphasing control and can be computed according to (37)-(40). Moreover, the discussion about zero-power and saturated power output levels for the Inverse RCN control similarly applies to this control method. Also, for the range of output powers (or equivalently, output voltage amplitudes) between the zero-points of the susceptances, the effective susceptance amplitude at each of the combiner inputs is substantially the same.

Still another control methodology, referred to as optimal phase (OP) outphasing control, is proposed which, in turn, is characterized with its two main advantages: (1) minimizes the effective input admittance phase seen by the PAs at each power level, and (2) ensures that each PA sees the same load phase magnitude. For the 4-way combiner addressed here (see FIG. 4), the optimal phase control angle pair $[\theta; \phi]$ can be computed for a particular output power level P_{out} by numerically minimizing the largest effective input admittance phase ϕ_{max} seen by the PAs (at P_{out}) (45) subject to the constraint set forth by Equation (46):

$$\phi_{max} = \max \left\{ \text{ATAN} \left(\left| \frac{\text{Im}\{Y_{eff,A}\}}{\text{Re}\{Y_{eff,A}\}} \right| \right), \text{ATAN} \left(\left| \frac{\text{Im}\{Y_{eff,B}\}}{\text{Re}\{Y_{eff,B}\}} \right| \right) \right\} \quad (45)$$

$$P_{out} = \frac{8R_L V_S^2}{X_1^2} \sin^2(\phi) \cos^2(\theta). \quad (46)$$

It can be shown that for the range of output power levels given by (47), the solutions of the preceding optimization problem (see Equations (45), (46)) reduce to a non-linear system of Equations (48) which can be solved for $[\theta; \phi]$ by employing conventional numerical methods.

$$\frac{4R_L^2 V_S^2 - 2V_S^2 \sqrt{4R_L^4 - R_L^2 X_1^2}}{X_1^2 R_L} \leq P_{out} \leq \frac{4R_L^2 V_S^2 + 2V_S^2 \sqrt{4R_L^4 - R_L^2 X_1^2}}{X_1^2 R_L} \quad (47)$$

$$\frac{P_{out} X_1^2}{8R_L V_S^2} = \sin^2(\phi) \cos^2(\theta) \quad (48)$$

$$\sin(2\phi) = \frac{2\gamma \cos^2(\theta)}{\beta^2 + 4\gamma^2 \cos^2(\theta) - 2\beta\gamma \sin(2\theta)}$$

As an example, FIGS. 19, 19A and 19B illustrate the effective input conductance, susceptance and phase (respectively) seen by each of the PAs driving the power combiner of FIG. 4 with $V_S=1V$, $R_L=50\Omega$, and $k=1.05$ and optimal phase control. The zero-points occur at the same output power levels as in the case of the Inverse RCN outphasing control and can be computed according to Equations (37)-(40). Moreover, the discussion about zero-power and saturated power output levels for the Inverse RCN control equally well applies to this control method. Also, for the range of output powers (or equivalently, output voltage amplitudes) between the zero-points of the susceptances, the effective immittance (admittance or impedance) phase amplitude at each of the combiner inputs is substantially the same.

All of the above methodologies can be adapted for the outphasing control of a general N-way power combiner. Moreover, one could switch methodologies based on operation over different power ranges or for different operating conditions if desired. Nevertheless, to compare the relative performance of each control method, consider as an example the power combiner of FIG. 4 with $R_L=50\Omega$, $V_S=1V$, and $k=1.05$. FIG. 20 shows the appropriate outphasing control angles θ and ϕ for each of the above control methods for an output power in the range $[0 W; P_{out,sat} \approx 0.3 W]$.

It can be clearly seen from FIG. 20 that the Optimal Phase and Optimal Susceptance control angles are almost entirely identical over a significant portion of the output power operating range. Thus by choosing the control angles to minimize the effective input admittance phase seen by the PAs, for all practical purposes, one effectively minimizes the susceptive components as well, and vice versa.

FIGS. 21 and 21A further demonstrates this observation by examining the worst-case input admittance phase magnitude and susceptance magnitude seen by the PAs for a particular output power level in the operating region of interest for the same 4-way power combiner as above. From FIGS. 21 and 21A, it can be seen that the optimal susceptance and optimal phase control methods result in approximately equivalent phase and susceptance characteristics over the main operating power range with over a factor of three improvement compared to the Inverse RCN control method. For this case, the inverse RCN control method yields less than 5 degrees of admittance phase magnitude over more than a factor of ten in power, while the optimal phase and optimal susceptance methods yield less than 1.6 degrees.

As already mentioned, the operating characteristics of an N-way power combiner system are uniquely determined by the selected value of k that is utilized for computation of the combiner's reactance magnitudes according to the recursive relations in Equations (30) and (31). A general approach is developed for selecting the appropriate value of k in order to satisfy a set of specific performance specifications. In particular, given an N-way power combiner and a specified output power operating range $[P_{out,min}, P_{out,max}]$ of interest, two design problems are considered: (1) determine a k -value that will minimize the worst-case effective input admittance phase seen at the input ports of the combiner over this operating range, or (2) determine a k -value that will minimize the worst-case effective input susceptance seen at the input ports of the combiner over the specified operating range. Note that the specified operating range is simply one over which there is particular interest in minimizing admittance phase or susceptance magnitude, and may or may not represent the full operating range of the system. Each of these two design problems is individually addressed below for the case of the 4-way combiner of FIG. 4.

Next described are techniques for designing for minimum effective input admittance phase magnitude.

Referring now to FIG. 22, FIG. 22 illustrates the worst-case input admittance phase versus output power level P_{out} (phase-power curve) seen by the PAs driving the 4-way combiner of FIG. 4 according to the Optimal Phase outphasing control for two distinct values of k . Suppose that the specified operating range of this combiner over which worst-case phase deviations are to be minimized is $[P_{min1}, P_{max1}]$. It can be theoretically shown that the optimal value of k minimizing the worst-case admittance phase seen over this operating range is such that the phase-power curve associated with it has a maximum phase ϕ_{max} equal to the worst-case admittance phases at P_{min1} and P_{max1} . As can be seen from FIG. 22, for the combiner considered here, this corresponds to $k=1.1$. If instead a wider operating range is specified, for instance $[P_{min2}, P_{max2}]$, a larger value of k will be necessary ($k=1.2$ for this example) as demonstrated by FIG. 22, and the maximum admittance phase that must be tolerated in this case will also increase (changing approximately from 3.1° to 8.1°). The developments above are valid and easily-adoptable for the general N-way combiner. In general, smaller k -values result in narrower power operating ranges for which worst-case phase is minimized and smaller worst-case admittance phase, while larger k -values allow wider operating power ranges over which worst-case phase is minimized at the expense of higher worst-case admittance phase. Increasing the order of the N-way combiner (larger N) expands its performance capabilities and allows it to operate in a given power range at smaller worst-case admittance phase compared to a lower-order power combiner.

For the case of the 4-way combiner of FIG. 4, FIG. 23 indicates the optimal value of k for a given specified output power range ratio (PRR), where PRR is the ratio of the maximum to the minimum output power over which peak phase deviations (from zero) are to be minimized. Power Ratio Curves for both the Inverse RCN and Optimal Phase control methods are shown. The value of k is found by tracing horizontally from the specified power ratio to the Power Ratio Curve of interest, and tracing vertically to find k . The corresponding worst-case admittance phase for the specified operating range (power ratio) can be obtained by tracing the k -value of choice vertically to the respective Phase Curve and horizontally (right) to the corresponding admittance phase.

FIG. 24 depicts the actual minimum and maximum output power levels (relating to the phase deviation peak for that value of k) for each of the two outphasing control methods normalized to $V_S=1V$, $R_L=1\Omega$ for a given k -value. To denormalize for a particular V_S and R_L , the limits must be multiplied by $V_S \cdot V_S / R_L$.

Next described are techniques for designing for minimum effective input susceptance magnitude.

The methodology for selecting the optimal value of k that will minimize the worst-case input susceptance over a specified operating power range $[P_{min}, P_{max}]$ is analogous to the one presented above. In this case, however, the optimal value of k is such that the susceptance-power curve associated with it has a maximum susceptance equal to the worst-case susceptance at P_{min} and P_{max} .

For the case of the 4-way combiner of FIG. 4, FIG. 25 indicates the optimal value of k for a given specified output power range ratio. Power Ratio Curves for both the Inverse RCN and Optimal Susceptance control methods are shown. The corresponding worst-case susceptance for the specified operating range can be obtained by tracing the k -value of choice to the Susceptance Curve (normalized to $R_L=1\Omega$). Susceptance can be denormalized by simply dividing it by the intended value of R_L . FIG. 28 depicts the respective minimum and maximum output power levels associated with the related peak susceptive deviation for both control methods normalized to $V_S=1V$, $R_L=1\Omega$ for a given k -value. To denormalize for a particular V_S and R_L , the limits must be multiplied by $V_S \cdot V_S / R_L$.

Using the information represented in FIGS. 23 and 24, it can be shown that over power ratios of 2, 5, 10, 20 and 50 the 4-way combiner can ideally achieve worst-case input admittance (or impedance, or generally imittance) phase amplitudes of 0.07, 0.78, 3.05, 8.18 and 25.36 degrees with the IRCN control method and 0.01, 0.31, 1.15, 3.01, and 9.35 degrees with the OP control method. Thus, achieving worst case phase variations of less than 1 degree over a factor of 5 in power, 5 degrees over a factor of ten in power, ten degrees over a factor of 20 in power and 30 degrees over a factor of 50 in power is possible in practice with a variety of control laws in keeping with this disclosure. Moreover, some control laws in keeping with this disclosure can practically achieve worst-case phase amplitudes of less than two degrees over a factor of ten in power, five degrees over a factor of twenty in power, and fifteen degrees over a factor of fifty in power. Still much smaller phase magnitudes (or wider power ranges at constant phase magnitudes) are achievable with an 8-way combining system.

Next described are a variety of power combiner topological implementations and transformations.

It should be appreciated that many of the concepts and techniques described herein have referred to the implementation shown in FIG. 4. This combiner implementation may

be thought of as including a binary tree of reactances having complementary reactances at each bifurcation in the tree.

It should be appreciated, however, that for a binary tree combiner implementation with M bifurcations, one has $N=2^M$ inputs and $2N-2$ reactive branches. As an example, FIG. 27 depicts such a "binary tree" implementation of an 8-way combiner ($N=8$). Nevertheless, various topological transformations may be applied to this basic "binary tree" realization to obtain other useful implementations of the combiner. Here we discuss two such types of topological transformations: (1) T- Δ network transformation (also known as the Y- Δ or star-triangle transformation), and (2) topological duality transformation. These transformations are used to and enumerate other possible topological implementations of the 4-way combiner; similar techniques can be used to synthesize other combiners in keeping with the present invention (e.g., for higher-order N). Although the input-port and output-port characteristics, as will be demonstrated below, remain largely unaffected under these transformations, depending on the application of the combiner and component values that result, one implementation may be preferred over another.

Referring now to FIG. 28, the general T- Δ network transformation of a three-terminal network is shown.

An important characteristic of the transformation is that it does not affect the transformed network's interface with other networks connected to its terminals. In other words, the current-voltage relationship at each terminal of the transformed network is preserved under the transformation. FIG. 29 depicts the same transformation applied to top T-network of the power combiner in FIG. 4.

Referring now to FIGS. 30-30D the 4-way combiner implementations that can result from applying the T- Δ transformation to the various T-networks found in the basic 4-way combiner of FIG. 4 (repeated in FIG. 30 for convenience) are shown.

Although unnecessary, it is convenient to think of the basic combiner in FIG. 30 as the starting point for all the T- Δ transformations. For this reason, the reactance magnitudes in all the implementation variants of FIG. 30A-30D are given in terms of the reactance magnitudes of the basic combiner. The suggested reactance magnitude values for a particular implementation ensure that its input-port and output-port characteristics are identical to those of the basic combiner, i.e. as far as the PAs and the load (transformed in the case of FIG. 30A) are concerned, the behavior of the transformed combiner for any outphasing control method will be equivalent to that of the basic combiner for the same outphasing control strategy and respective load. It should be noted that the same transformations can be applied to the combiner and load networks in other power combiner implementations, including those of higher order N .

FIGS. 31 and 31A-31D shows the topology of the corresponding topological duals of each of the networks including 4-way combiner implementations of FIGS. 30 and 30A-30D. Specific component values may be found for the dual network as is well known in the art. As a result of this transformation, the PAs (approximated by voltage sources V_A - V_D in FIGS. 30 and 30A-30D) are now modeled respectively by current sources I_A - I_D having equivalent magnitude and phase relationship as the voltage sources of FIGS. 30 and 30A-30D, though it is recognized that this is for modeling purposes, and to show the connection ports of the power amplifiers—the power amplifiers needn't act as ideal voltage or current sources.

Further, it is of significant importance to note that for any particular outphasing control method, the input admittance versus output power characteristic of the FIGS. 29 and 29A-

29D permutations is equivalent to the input impedance versus output power characteristic of their respective duals. Conveniently, the relationship between the output power delivered to the load and the outphasing control methodology is unaffected by the topological duality transformation. Thus, all of the presented outphasing control methods previously introduced are directly applicable to the implementation variants of FIGS. 30 and 30A-30D, although, in this case, it will be more appropriate to refer to the Optimal Susceptance control method as the Optimal Reactance control method, in keeping with the effects of topological duality on interchanging voltages and currents and admittances and impedances. (We note that there are also other methods for synthesizing the networks of FIGS. 30 and 30A-30D, such as starting with other types of multi-level resistance compression networks.)

There are also numerous other variations of the novel concepts, systems and techniques described and claimed herein. For example, these include one or more of: (a) outphasing groups of this type of combined PA using a conventional isolating combiner (with or without energy recovery); (b) operation of power amplifiers with the proposed combining and outphasing, additionally using drain voltage modulation or power amplifier supply voltage modulation (adaptive bias, polar modulation, discrete drain switching, asymmetric multilevel outphasing, multi-level LINC etc.); (c) application of gate-width switching of the power amplifiers to reduce losses at small output powers; (d) operation of power amplifiers with the proposed combining and outphasing hybridized with other control strategies. This would include using class AB, class B or Doherty-type or other types of PAs in saturation under outphasing over part of the power range and backing into linear operation over part of the range, use of adaptive bias of the power amplifiers over the operating range, hybridizing with duty cycle control or discrete pulse modulation, etc.; (e) adaptively modulating subsets of the amplifiers on and off as an additional form of power control.

After reading the description provided herein, one of ordinary skill in the art will now appreciate that the concepts, systems and techniques described herein overcome the limitations of previous outphasing power amplifier circuits and systems. In particular, the power combining and outphasing circuits, system and techniques described herein overcome the loss and reactive loading problems of prior art outphasing approaches. The power combining and outphasing circuits, system and techniques described herein provide ideally lossless power combining, along with substantially resistive loading of individual power amplifiers over a very wide output power range, enabling high average efficiency to be achieved even for large peak-to-average power ratios (PAPR).

Having described preferred embodiments of the invention it will now become apparent to those of ordinary skill in the art that other embodiments incorporating these concepts may be used. Accordingly, it is submitted that that the invention should not be limited to the described embodiments but rather should be limited only by the spirit and scope of the appended claims.

The invention claimed is:

1. A system for delivering and controlling power from a number N greater than two radio-frequency (RF) power sources to a single output, the system comprising:

N RF power sources each having an output port, each of said N RF power sources configured to deliver RF power to its output port:

a lossless power combiner, said lossless power combiner comprising N input ports, $2N-2$ reactive branches having specified reactance values, and an output port configured to receive RF power, wherein each of the output

ports of the N RF power sources are coupled to a corresponding one of the N input ports of said lossless power combiner, and RF power delivered to the output port of said power combiner is controlled by adjusting the phases of the N radio-frequency power sources as a function of the reactance values of the $2N-2$ reactive branches.

2. The system of claim 1 wherein in response to adjusting the phases of the N radio-frequency power sources as a function of the reactance values of the $2N-2$ reactive branches, an effective loading impedance presented to each of said N RF power sources at the input ports of said power combiner are purely resistive at N output power levels.

3. The system of claim 1 wherein the largest magnitudes of the susceptive portion of an effective loading admittances seen by said N RF power sources are smaller than is achievable with any combination of Chireix and lossless in-phase power combining over a range of RF output power levels bounded by highest and lowest RF output power levels where said purely resistive loading of said radio-frequency power sources occurs.

4. A radio-frequency (RF) system comprising:

four or more RF signal sources each of said four or more RF signal sources having an output port; and

a reactive power combiner having N input ports and an output port, where N is greater than or equal to four with each of the N reactive power combiner input ports coupled to a corresponding one of the four or more RF signal source output ports and wherein said reactive power combiner includes $2N-2$ reactive branches, each of the $2N-2$ reactive branches having a predetermined reactance value, wherein power delivered to the reactive power combiner output port is controlled by adjusting a phase characteristic of each of said four or more RF signal sources as a function of the reactance values of the $2N-2$ reactive branches.

5. The RF system of claim 4 wherein each of said four or more RF signal sources comprise an RF amplifier having an RF input port and an RF output port coupled to a respective one of the input ports of said reactive power combiner.

6. The RF system of claim 4 wherein the number of input ports of said reactive power combiner matches the number of RF signal sources.

7. The RF system of claim 4 wherein each of said $2N-2$ reactive branches of said power combiner comprises at least one reactive element with first ones of the reactive elements having a first specified reactance magnitude at an operating frequency and second ones of the reactive elements have a second, different specified reactance magnitude at the operating frequency.

8. The RF system of claim 4 wherein each of said $2N-2$ reactive branches of said power combiner comprises at least one reactive element with first ones of the reactive elements having a first specified reactance at an operating frequency and second ones of the reactive elements have a second, opposite specified reactance at the operating frequency.

9. The RF system of claim 4 wherein the reactance values of each of said $2N-2$ reactive branches of said reactive power combiner are selected such that said reactive power combiner provides dominantly resistive loading of each of the RF signal sources coupled to the reactive power combiner input ports over a range of output power.

10. The RF system of claim 4 wherein the combination of said four or more RF signal sources and said reactive power combiner form a power amplifier circuit.

33

11. The RF system of claim 10 further comprising:
a plurality of power amplifier circuits; and
an isolating combiner coupled between pairs of said plurality of power amplifier circuits such that outphasing groups of said power amplifier circuits can be achieved.

12. The RF system of claim 11 further comprising a drain modulation circuit coupled to each of said power amplifier circuits.

13. The RF system of claim 12 wherein said drain modulation circuit comprises one or more of: an adaptive bias circuit, a polar modulation circuit, a discrete drain switching circuit.

14. The RF system of claim 12 wherein said drain modulation circuit operates in accordance with an asymmetric multilevel outphasing technique.

15. The RF system of claim 12 wherein said drain modulation circuit implements gate-width switching of the power amplifiers to reduce losses at small output powers.

16. The RF system of claim 4 wherein said reactive power combiner comprises at least one of:

- one or more distributed circuit elements;
- one or more lumped circuit elements; or
- a combination of distributed and lumped circuit elements.

17. The system of claim 4 wherein relative phases between each of said four or more RF signal sources are controlled such that a worst case effective immittance phase amplitude seen at any of the power combiner inputs is limited as output power varies over a specified ratio, said worst-case effective immittance phase amplitudes satisfying at least one of:

- less than 1 degree over a factor of 6 in power;
- less than 5 degrees over a factor of ten in power;
- less than 10 degrees over a factor of 20 in power; and
- less than 30 degrees over a factor of 50 in power.

18. The system of claim 4 wherein relative phases between each of said four or more RF signal sources are controlled such that a worst case effective immittance phase amplitude seen at any of the power combiner inputs is limited as output power varies over a specified ratio, said worst-case effective immittance phase amplitudes satisfying at least one of:

- less than two degrees over a factor of ten in power;
- five degrees over a factor of twenty in power; and
- fifteen degrees over a factor of fifty in power.

19. The system of claim 4 wherein relative phases between said RF signal sources are adjusted as a continuous function of output power or voltage amplitude.

20. A radio-frequency (RF) system comprising:

- N greater than or equal to 8 RF signal sources each of said at least N RF signal sources having an output port; and
- a reactive power combiner having at least eight input ports and an output port, each reactive power combiner input port coupled to a corresponding one of the RF signal source output ports and wherein said reactive power combiner includes $2N-2$ reactive branches, each of the $2N-2$ reactive branches having a predetermined reactance value, wherein the power delivered to the reactive power combiner output port is controlled by adjusting a phase characteristic of each of said N RF signal sources as a function of the reactance values of the $2N-2$ reactive branches.

21. The system of claim 20 wherein relative phases between each of said N RF signal sources are controlled such that the worst case effective immittance phase amplitude seen at any of the power combiner inputs is limited as output power varies over a specified ratio, said worst-case phase amplitudes satisfying at least one of;

- less than 1 degree over a factor of 5 in power;
- less than 5 degrees over a factor of ten in power;

34

less than 10 degrees over a factor of 20 in power; and
less than 30 degrees over a factor of 50 in power.

22. The system of claim 20 wherein the relative phases of each of said N RF signal sources are controlled such that the worst case effective immittance phase amplitude seen at any of the power combiner inputs is limited as output power varies over a specified ratio, said worst-case phase amplitudes satisfying at least one of:

- less than two degrees over a factor of ten in power;
- five degrees over a factor of twenty in power; and
- fifteen degrees over a factor of fifty in power.

23. A power amplifier system comprising:

N power amplifiers where $N=2^M$ and M is an integer greater than one, each of the N power amplifiers having an input port and an output port;

a reactive combiner having an output port and N input ports, each of the N input ports of said reactive combiner coupled to an output of a respective one of the N power amplifiers, said reactive combiner including a plurality of reactive branches with each of the reactive branches having an impedance characteristic corresponding to one of M specified impedance levels; and

a control system configured to adjust an amplitude of a voltage at the output of the reactive combiner by controlling a relative phase between the N power amplifiers as a function of all of the M specified impedance levels.

24. The system of claim 23 wherein effective susceptances at the N inputs of the reactive combiner are zero for at least N output voltage amplitudes.

25. The system of claim 24 wherein for the range of output voltage amplitudes between those for which said effective susceptances are zero, the effective susceptance amplitude at each of the combiner inputs is substantially the same.

26. The system of claim 24 wherein for the range of output voltage amplitudes between those for which said effective susceptances are zero, the effective immittance phase amplitude at each of the combiner inputs is substantially the same.

27. The system of claim 23 wherein said M specified impedance levels are selected as a function of a single design parameter and a specified bad resistance.

28. The system of claim 23 wherein there are $2N-2$ of said reactive branches with 2^m branches having an impedance magnitude at the $m^{th}=1 \dots M$ impedance level.

29. The system of claim 23 wherein the reactive power combiner can be transformed into a network including a binary tree of reactances having complementary reactances at each bifurcation in the tree through application of zero or more of:

- T-Delta transformations; and
- topological duality transformations.

30. The system of claim 23 wherein $M=3$.

31. The system of claim 30 wherein the relative phases of each of said N power amplifiers are controlled such that an effective immittance phase amplitude seen at any of the reactive combiner inputs is limited as output power varies over a specified ratio, said effective immittance phase amplitudes satisfying at least one of:

- 1 degree for 20:1 power;
- 2 degrees for 50:1 power; and
- 5 degrees for 100:1 power.

32. The system of claim 23 wherein said control system is further configured to adjust an amplitude of a voltage at the output of the reactive combiner by controlling one or more of:
the power supply voltages of said N power amplifiers; and
the RF input drive amplitudes of said N power amplifiers.